



US-A Fabrika Otomasyon ve mühendislik Tic. A.Ş.  
www.usa-fa.com.tr

Phone : +90 (216) 517 88 85

Fax : +90 (216) 517 88 86

E-posta : satis@tr-us-a.com

Şirket / Müşteri : Esan Eczacıbaşı Endüstriyel Hammaddeler San. ve Tic. A.Ş.  
(Company / Customer)

Yetkili : Önder KURT  
(Commision)

Proje Adı : Esan Eczacıbaşı Milas ÜYS YENİ KURUTMA  
(Project Name)

Güç Beslemesi : 400 V 50 Hz 800 A  
( Power Supply )

Proje Numarası : 230201  
(Project No)

Kumanda Voltajı : 24 V DC  
( Control Voltage )

Proje Sorumlusu : Ufuk GÜLÇEN  
(Project Manager)

Proje Onay :

Oluşturma Tarihi : 13.09.2023  
( Creation Date )

Toplam Sayfa : 255  
( Total Page )

Cizen (Drawing)	Kontrol (Control)	US  A	Kontrol (Control)	esan	Tag Number	Lokasyon	Sayfa açıklaması (Page description)	Proje adı (Project name)	Page:
Necip SERT Proje Tasarım	Ufuk GÜLÇEN Proje Sorumlusu		Önder KURT Proje Sorumlusu				Kapak Sayfası	Esan Eczacıbaşı Milas ÜYS YENİ KURUTMA	= + Next page: &AAB1/1 Previous page:



US-A Fabrika Otomasyon ve mühendislik Tic. A.Ş.  
www.usa-fa.com.tr

Phone : +90 (216) 517 88 85

Fax : +90 (216) 517 88 86

E-posta : satis@tr-us-a.com

Esan Eczacıbaşı Milas ÜYS YENİ KURUTMA

=

+

& AAB1

İçindekiler dizini

Cizen (Drawing)	Kontrol (Control)	Tag Number	Lokasyon	Sayfa açıklaması (Page description)	Proje adı (Project name)
Necip SERT Proje Tasarım	Ufuk GÜLÇEN Proje Sorumlusu			Sayfa Açıklaması	Esan Eczacıbaşı Milas ÜYS YENİ KURUTMA
					=
					+
					Next page: 2
					Previous page: &/1









# İçindekiler dizini

Sayfa	Sayfa açıklaması	Tag Number	Lokasyon	Tarih	Düzenleyen	X
+MCC&EFS1/51.a	Elevatör Besleme Bandı	ESTR-MLS-DRY2-CNV044-XM1	MCC-4.5	5.12.2023	Necip SERT	
+MCC&EFS1/51.b	Elevatör Besleme Bandı	ESTR-MLS-DRY2-CNV044-XM1	MCC-4.5	5.12.2023	Necip SERT	
+MCC&EFS1/51.c	Elevatör Besleme Bandı	ESTR-MLS-DRY2-CNV044-XM1	MCC-4.5	5.12.2023	Necip SERT	
+MCC&EFS1/52.a	Manyetik Permröl-1-1	ESTR-MLS-DRY2-MSP014-XM1	MCC-8.1	5.12.2023	Necip SERT	
+MCC&EFS1/52.b	Manyetik Permröl-1-1	ESTR-MLS-DRY2-MSP014-XM1	MCC-8.1	5.12.2023	Necip SERT	
+MCC&EFS1/52.c	Manyetik Permröl-1-1	ESTR-MLS-DRY2-MSP014-XM1	MCC-8.1	5.12.2023	Necip SERT	
+MCC&EFS1/53.a	Manyetik Permröl-1-2	ESTR-MLS-DRY2-MSP014-XM2	MCC-8.2	5.12.2023	Necip SERT	
+MCC&EFS1/53.b	Manyetik Permröl-1-2	ESTR-MLS-DRY2-MSP014-XM2	MCC-8.2	5.12.2023	Necip SERT	
+MCC&EFS1/53.c	Manyetik Permröl-1-2	ESTR-MLS-DRY2-MSP014-XM2	MCC-8.2	5.12.2023	Necip SERT	
+MCC&EFS1/54.a	Manyetik Permröl-1-3	ESTR-MLS-DRY2-MSP014-XM3	MCC-8.3	5.12.2023	Necip SERT	
+MCC&EFS1/54.b	Manyetik Permröl-1-3	ESTR-MLS-DRY2-MSP014-XM3	MCC-8.3	5.12.2023	Necip SERT	
+MCC&EFS1/54.c	Manyetik Permröl-1-3	ESTR-MLS-DRY2-MSP014-XM3	MCC-8.3	5.12.2023	Necip SERT	
+MCC&EFS1/55.a	Manyetik Permröl-2-1	ESTR-MLS-DRY2-MSP015-XM1	MCC-8.4	5.12.2023	Necip SERT	
+MCC&EFS1/55.b	Manyetik Permröl-2-1	ESTR-MLS-DRY2-MSP015-XM1	MCC-8.4	5.12.2023	Necip SERT	
+MCC&EFS1/55.c	Manyetik Permröl-2-1	ESTR-MLS-DRY2-MSP015-XM1	MCC-8.4	5.12.2023	Necip SERT	
+MCC&EFS1/56.a	Manyetik Permröl-2-2	ESTR-MLS-DRY2-MSP015-XM2	MCC-21.1	5.12.2023	Necip SERT	
+MCC&EFS1/56.b	Manyetik Permröl-2-2	ESTR-MLS-DRY2-MSP015-XM2	MCC-21.1	5.12.2023	Necip SERT	
+MCC&EFS1/56.c	Manyetik Permröl-2-2	ESTR-MLS-DRY2-MSP015-XM2	MCC-21.1	5.12.2023	Necip SERT	
+MCC&EFS1/57.a	Manyetik Permröl-2-3	ESTR-MLS-DRY2-MSP015-XM3	MCC-21.2	5.12.2023	Necip SERT	
+MCC&EFS1/57.b	Manyetik Permröl-2-3	ESTR-MLS-DRY2-MSP015-XM3	MCC-21.2	5.12.2023	Necip SERT	
+MCC&EFS1/57.c	Manyetik Permröl-2-3	ESTR-MLS-DRY2-MSP015-XM3	MCC-21.2	5.12.2023	Necip SERT	
+MCC&EFS1/58.a	YEDEK	YEDEK	MCC-25.2	5.12.2023	Necip SERT	
+MCC&EFS1/58.b	YEDEK	YEDEK	MCC-25.2	5.12.2023	Necip SERT	
+MCC&EFS1/58.c	YEDEK	YEDEK	MCC-25.2	5.12.2023	Necip SERT	
+MCC&EFS1/59.a	YEDEK	YEDEK	MCC-25.3	5.12.2023	Necip SERT	
+MCC&EFS1/59.b	YEDEK	YEDEK	MCC-25.3	5.12.2023	Necip SERT	
+MCC&EFS1/59.c	YEDEK	YEDEK	MCC-25.3	5.12.2023	Necip SERT	
+MCC&EFS1/60.a	YEDEK	YEDEK	MCC-25.4	5.12.2023	Necip SERT	
+MCC&EFS1/60.b	YEDEK	YEDEK	MCC-25.4	5.12.2023	Necip SERT	
+MCC&EFS1/60.c	YEDEK	YEDEK	MCC-25.4	5.12.2023	Necip SERT	
+MCC&EFS1/61.a	YEDEK	YEDEK	MCC-25.5	5.12.2023	Necip SERT	
+MCC&EFS1/61.b	YEDEK	YEDEK	MCC-25.5	5.12.2023	Necip SERT	
+MCC&EFS1/61.c	YEDEK	YEDEK	MCC-25.5	5.12.2023	Necip SERT	

2.b

Page: 2.c

Cizen (Drawing)	Kontrol (Control)		Kontrol (Control)		Tag Number	Lokasyon	Sayfa açıklaması (Page description)	Proje adı (Project name)	=
Necip SERT Proje Tasarım	Ufuk GÜLÇEN Proje Sorumlusu		Önder KURT Proje Sorumlusu					İçindekiler dizini : +MCC&EFS1/51.a - +MCC&EFS1/61.c	Esan Eczacıbaşı Milas ÜYŞ YENİ KURUTMA

# İçindekiler dizini

Sayfa	Sayfa açıklaması	Tag Number	Lokasyon	Tarih	Düzenleyen	X
+MCC&EFS1/62.a	YEDEK	YEDEK	MCC-25.6	5.12.2023	Necip SERT	
+MCC&EFS1/62.b	YEDEK	YEDEK	MCC-25.6	5.12.2023	Necip SERT	
+MCC&EFS1/62.c	YEDEK	YEDEK	MCC-25.6	5.12.2023	Necip SERT	
+MCC&EFS1/63.a	YEDEK	YEDEK	MCC-25.7	5.12.2023	Necip SERT	
+MCC&EFS1/63.b	YEDEK	YEDEK	MCC-25.7	5.12.2023	Necip SERT	
+MCC&EFS1/63.c	YEDEK	YEDEK	MCC-25.7	5.12.2023	Necip SERT	
+MCC&EFS1/64.a	YEDEK	YEDEK	MCC-25.8	5.12.2023	Necip SERT	
+MCC&EFS1/64.b	YEDEK	YEDEK	MCC-25.8	5.12.2023	Necip SERT	
+MCC&EFS1/64.c	YEDEK	YEDEK	MCC-25.8	5.12.2023	Necip SERT	
+MCC&EFS1/65.a	YEDEK	YEDEK	MCC-14	5.12.2023	Necip SERT	
+MCC&EFS1/65.b	YEDEK	YEDEK	MCC-14	5.12.2023	Necip SERT	
+MCC&EFS1/65.c	YEDEK	YEDEK	MCC-14	5.12.2023	Necip SERT	
+MCC&EFS1/66.a	YEDEK	YEDEK	MCC-16	5.12.2023	Necip SERT	
+MCC&EFS1/66.b	YEDEK	YEDEK	MCC-16	5.12.2023	Necip SERT	
+MCC&EFS1/66.c	YEDEK	YEDEK	MCC-16	5.12.2023	Necip SERT	
+MCC&EFS1/67.a	YEDEK	YEDEK	MCC-12.2	5.12.2023	Necip SERT	
+MCC&EFS1/67.b	YEDEK	YEDEK	MCC-12.2	5.12.2023	Necip SERT	
+MCC&EFS1/67.c	YEDEK	YEDEK	MCC-12.2	5.12.2023	Necip SERT	
+MCC&EFS1/68.a	YEDEK	YEDEK	MCC-21.4	5.12.2023	Necip SERT	
+MCC&EFS1/68.b	YEDEK	YEDEK	MCC-21.4	5.12.2023	Necip SERT	
+MCC&EFS1/68.c	YEDEK	YEDEK	MCC-21.4	5.12.2023	Necip SERT	
+MCC&EFS1/80.a	250A ÇIKIŞ		MCC-10	6.12.2023	Necip SERT	
+MCC&EFS1/80.b	250A ÇIKIŞ	MERKEZİ KOMPRESÖR	MCC-10	6.12.2023	Necip SERT	
+MCC&EFS1/81	ÇIKIŞLAR-1		MCC-10	7.12.2023	Necip SERT	
+MCC&EFS1/82	ÇIKIŞLAR-2		MCC-10	7.12.2023	Necip SERT	
+MCC&EFS1/83	UPS ÇIKIŞ		MCC-10	7.12.2023	Necip SERT	
+MCC&EFS1/84	TRAFİK LAMBASI VE SİREN		MCC-18	6.12.2023	Necip SERT	
+MCC&EFS1/85	DÖNER FIRIN YAĞLAMA VE HAVA TOPU		MCC-24	6.12.2023	Necip SERT	
+DCS&EFS1/11	Güç Sayfası - 1			5.12.2023	Necip SERT	
+DCS&EFS1/13.a	Güç Kaynağı - 1			5.12.2023	Necip SERT	
+DCS&EFS1/13.b	Güç Kaynağı - 2			5.12.2023	Necip SERT	
+DCS&EFS1/14	Havalandırma Ve Aydınlatma			5.12.2023	Necip SERT	
+DCS&EFS1/16.a	RACK - 13 24VDC Modül Besleme Dağıtım			5.12.2023	Necip SERT	

2.c

Page: 2.d

Cizen (Drawing)	Kontrol (Control)	Kontrol (Control)	Tag Number	Lokasyon	Sayfa açıklaması (Page description)	Proje adı (Project name)	=
Necip SERT Proje Tasarım	Ufuk GÜLÇEN Proje Sorumlusu	Önder KURT Proje Sorumlusu			İçindekiler dizini : +MCC&EFS1/62.a - +DCS&EFS1/16.a	Esan Eczacıbaşı Milas ÜYİS YENİ KURUTMA	
							Next page: 2.e
							Previous page: 2.c





# İçindekiler dizini

Sayfa	Sayfa açıklaması	Tag Number	Lokasyon	Tarih	Düzenleyen	X
+DCS&EFS1/16.b	RACK - 13 24VDC Terminal Besleme Dağıtım			5.12.2023	Necip SERT	
+DCS&EFS1/17.a	RACK - 14 24VDC Modül Besleme Dağıtım			5.12.2023	Necip SERT	
+DCS&EFS1/17.b	RACK - 14 24VDC Terminal Besleme Dağıtım			5.12.2023	Necip SERT	
+DCS&EFS1/23	Network Ağ Bağlantıları			5.12.2023	Necip SERT	
+DCS&EFS1/24	REDUNDANT CPU 24VDC Besleme			5.12.2023	Necip SERT	
+DCS&EFS1/25	RACK - 11 24VDC Modül Besleme			5.12.2023	Necip SERT	
+DCS&EFS1/26	RACK - 12 24VDC Modül Besleme			5.12.2023	Necip SERT	
+DCS&EFS1/31.a	RACK - 13 SLOT - 1 Digital Input (32 Channel ) (1-16) 2 WIRE			5.12.2023	Necip SERT	
+DCS&EFS1/31.b	RACK - 13 SLOT - 1 Digital Input (32 Channel ) (17-32) 2 WIRE			5.12.2023	Necip SERT	
+DCS&EFS1/32.a	RACK - 13 SLOT - 2 Digital Input (32 Channel ) (1-16) 2 WIRE			5.12.2023	Necip SERT	
+DCS&EFS1/32.b	RACK - 13 SLOT - 2 Digital Input (32 Channel ) (17-32) 2 WIRE			5.12.2023	Necip SERT	
+DCS&EFS1/33.a	RACK - 13 SLOT - 3 Digital Input (32 Channel ) (1-16) 2 WIRE			5.12.2023	Necip SERT	
+DCS&EFS1/33.b	RACK - 13 SLOT - 3 Digital Input (32 Channel ) (17-32) 2 WIRE			5.12.2023	Necip SERT	
+DCS&EFS1/34.a	RACK - 13 SLOT - 4 Digital Input (32 Channel ) (1-16) 2 WIRE			5.12.2023	Necip SERT	
+DCS&EFS1/34.b	RACK - 13 SLOT - 4 Digital Input (32 Channel ) (17-32) 2 WIRE			5.12.2023	Necip SERT	
+DCS&EFS1/35.a	RACK - 13 SLOT - 5 Digital Output (32 Channel ) (1-8) DRY CONTACT			5.12.2023	Necip SERT	
+DCS&EFS1/35.b	RACK - 13 SLOT - 5 Digital Output (32 Channel ) (9-16) DRY CONTACT			5.12.2023	Necip SERT	
+DCS&EFS1/35.c	RACK - 13 SLOT - 5 Digital Output (32 Channel ) (17-22) DRY CONTACT			5.12.2023	Necip SERT	
+DCS&EFS1/35.d	RACK - 13 SLOT - 5 Digital Output (32 Channel ) (23-32) DRY CONTACT			5.12.2023	Necip SERT	
+DCS&EFS1/36.a	RACK - 13 SLOT - 6 Digital Output (32 Channel ) (1-8) LIVE CONTACT			5.12.2023	Necip SERT	
+DCS&EFS1/36.b	RACK - 13 SLOT - 6 Digital Output (32 Channel ) (9-16) LIVE CONTACT			5.12.2023	Necip SERT	
+DCS&EFS1/36.c	RACK - 13 SLOT - 6 Digital Output (32 Channel ) (17-22) LIVE CONTACT			5.12.2023	Necip SERT	
+DCS&EFS1/36.d	RACK - 13 SLOT - 6 Digital Output (32 Channel ) (23-32) LIVE CONTACT			5.12.2023	Necip SERT	
+DCS&EFS1/37	RACK - 13 SLOT - 07 Analog Output (8 Channel ) (1-8) 2 WIRE			5.12.2023	Necip SERT	
+DCS&EFS1/38.a	RACK - 13 SLOT - 8 Analog Input (16 Channel ) (1-8) HI LEVEL			5.12.2023	Necip SERT	
+DCS&EFS1/38.b	RACK - 13 SLOT - 8 Analog Input (16 Channel ) (9-16) HI LEVEL			5.12.2023	Necip SERT	
+DCS&EFS1/39.a	RACK - 13 SLOT - 9 Analog Input (8 Channel ) (1-4) RTD			5.12.2023	Necip SERT	
+DCS&EFS1/39.b	RACK - 13 SLOT - 9 Analog Input (8 Channel ) (5-8) RTD			5.12.2023	Necip SERT	
+DCS&EFS1/40.a	RACK - 13 SLOT - 10 Analog Input (8 Channel ) (1-4) RTD			5.12.2023	Necip SERT	
+DCS&EFS1/40.b	RACK - 13 SLOT - 10 Analog Input (8 Channel ) (5-8) RTD			5.12.2023	Necip SERT	
+DCS&EFS1/43.a	RACK - 14 SLOT - 1 Digital Input (32 Channel ) (1-16) 2 WIRE			5.12.2023	Necip SERT	
+DCS&EFS1/43.b	RACK - 14 SLOT - 1 Digital Input (32 Channel ) (17-32) 2 WIRE			5.12.2023	Necip SERT	
+DCS&EFS1/44.a	RACK - 14 SLOT - 2 Digital Input (32 Channel ) (1-16) 2 WIRE			5.12.2023	Necip SERT	

2.d

Page: 2.e

Cizen (Drawing)	Kontrol (Control)		Kontrol (Control)		Tag Number	Lokasyon	Sayfa açıklaması (Page description)	Proje adı (Project name)	=
Necip SERT Proje Tasarım	Ufuk GÜLÇEN Proje Sorumlusu		Önder KURT Proje Sorumlusu					İçindekiler dizini : +DCS&EFS1/16.b - +DCS&EFS1/44.a	Esan Eczacıbaşı Milas ÜYŞ YENİ KURUTMA







US-A Fabrika Otomasyon ve mühendislik Tic. A.Ş.  
www.usa-fa.com.tr

Phone : +90 (216) 517 88 85

Fax : +90 (216) 517 88 86

E-posta : satis@tr-us-a.com

Esan Eczacıbaşı Milas ÜYS YENİ KURUTMA

=





+

& ADB1

Yapı açıklaması



Cizen (Drawing)	Kontrol (Control)	US  A Unique Solutions at Applications an EPC company	Kontrol (Control)	esan	Tag Number	Lokasyon	Sayfa açıklaması (Page description)	Proje adı (Project name)	=
Necip SERT Proje Tasarım	Ufuk GÜLÇEN Proje Sorumlusu		Önder KURT Proje Sorumlusu				Sayfa Açıklaması	Esan Eczacıbaşı Milas ÜYS YENİ KURUTMA	+ Next page: 3 Previous page: &AAB1/2.f

# MCC Pano İçi Kablo Detay Açıklaması

DEVRE	RENK	COLOR	UYGULAMA	AÇIKLAMA
Güç ( L1 )	Siyah	BK	400 VAC	
Güç ( L2 )	Kahverengi	BN	400 VAC	
Güç ( L3 )	Gri	GY	400 VAC	
Nötr	Mavi	BU	400 VAC	
PE	Yeşil/Sarı	GNYE	PE	
Kumanda Voltaj DC	Kırmızı	RD	24 VDC, Kumanda Voltaj	
Kumanda Voltaj DC	Beyaz	WH	0 VDC, Kumanda voltaj	
Dijital Input	Mor	VT		
Dijital Output	Turuncu	OG		
Analog Input,Universal AI	Yeşil	GN		
Analog Output,Universal AO	Sarı	YE		

# DCS Pano İçi Kablo Detay Açıklaması

DEVRE	RENK	COLOR	UYGULAMA	AÇIKLAMA
Güç ( L )	Siyah	BK	220 VAC	
Nötr	Mavi	BU	220 VAC	
PE	Yeşil/Sarı	GNYE	PE	
Kumanda Voltaj DC	Kırmızı	RD	24 VDC, Kumanda Voltaj	
Kumanda Voltaj DC	Beyaz	WH	0 VDC, Kumanda voltaj	
Dijital Input	Mor	VT		
Dijital Output	Turuncu	OG		
Analog Input,Universal AI	Yeşil	GN		
Analog Output,Universal AO	Sarı	YE		

Çizen (Drawing)	Kontrol (Control)		Kontrol (Control)		Tag Number	Lokasyon	Sayfa açıklaması (Page description)	Proje adı (Project name)	=
Necip SERT Proje Tasarım	Ufuk GÜLÇEN Proje Sorumlusu		Önder KURT Proje Sorumlusu				DCS Kablo Özellikleri	Esan Eczacıbaşı Milas ÜYS YENİ KURUTMA	+ Next page: 5 Previous page: 3







US-A Fabrika Otomasyon ve mühendislik Tic. A.Ş.  
www.usa-fa.com.tr

Phone : +90 (216) 517 88 85

Fax : +90 (216) 517 88 86

E-posta : satis@tr-us-a.com

Esan Eczacıbaşı Milas ÜYS YENİ KURUTMA

=

+ MCC

KURUTMA MCC PANOSU

& EFS1

Devre şeması Elektrik tekniği

Cizen (Drawing)	Kontrol (Control)	US  A Unique Solutions at Applications an EPC company	Kontrol (Control)	esana	Tag Number	Lokasyon	Sayfa açıklaması (Page description)	Proje adı (Project name)	=
Necip SERT Proje Tasarım	Ufuk GÜLÇEN Proje Sorumlusu		Önder KURT Proje Sorumlusu				Sayfa Açıklaması	Esan Eczacıbaşı Milas ÜYS YENİ KURUTMA	+ MCC
									Next page: 11.b
									Previous page: +&ADB1/6

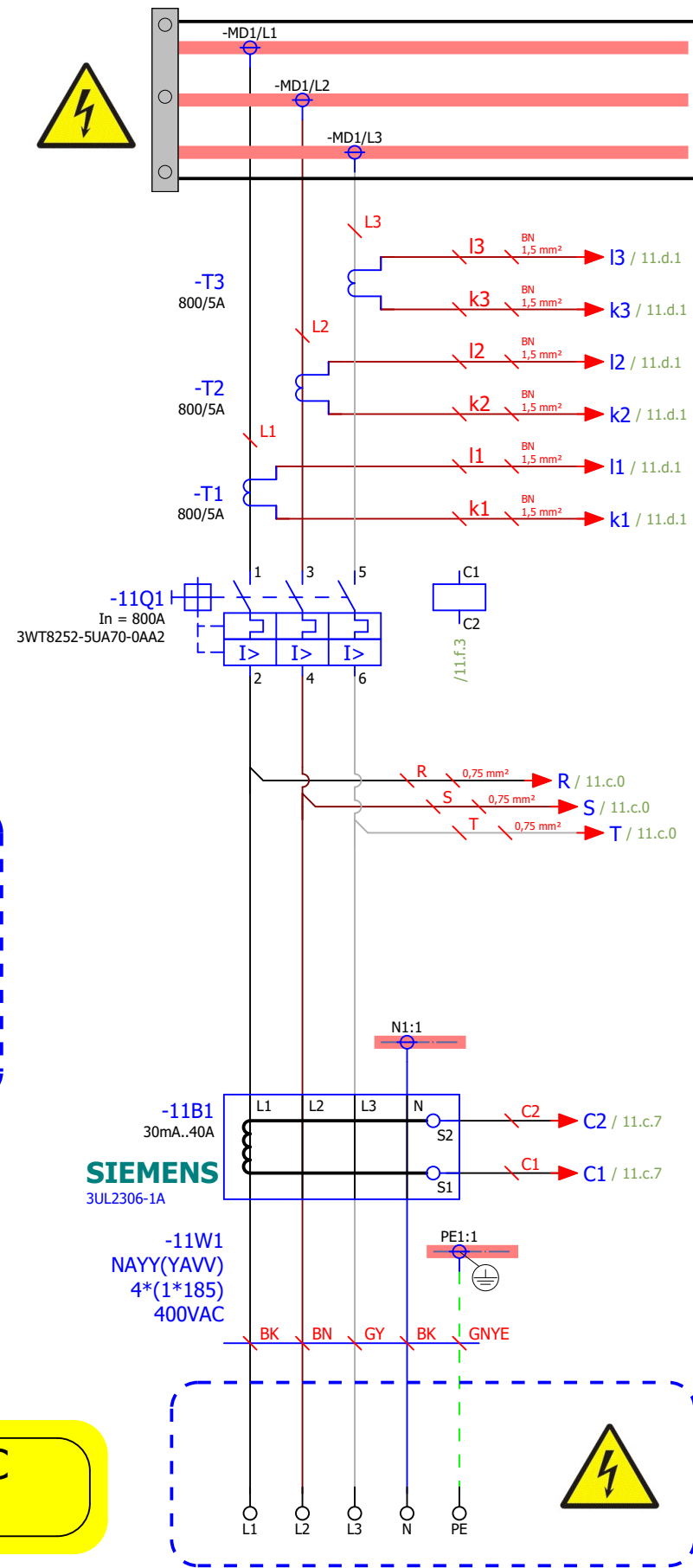

Cizen (Drawing)	Kontrol (Control)	USIA	Kontrol (Control)	esan	Tag Number	Lokasyon	Sayfa açıklaması (Page description)	Proje adı (Project name)	=
Necip SERT Proje Tasarım	Ufuk GÜLÇEN Proje Sorumlusu		Önder KURT Proje Sorumlusu				Ana Şalter Güç Devresi	Esan Eczacıbaşı Milas ÜYS YENİ KURUTMA	
									+
									Next page: 11.c
									Previous page: 1



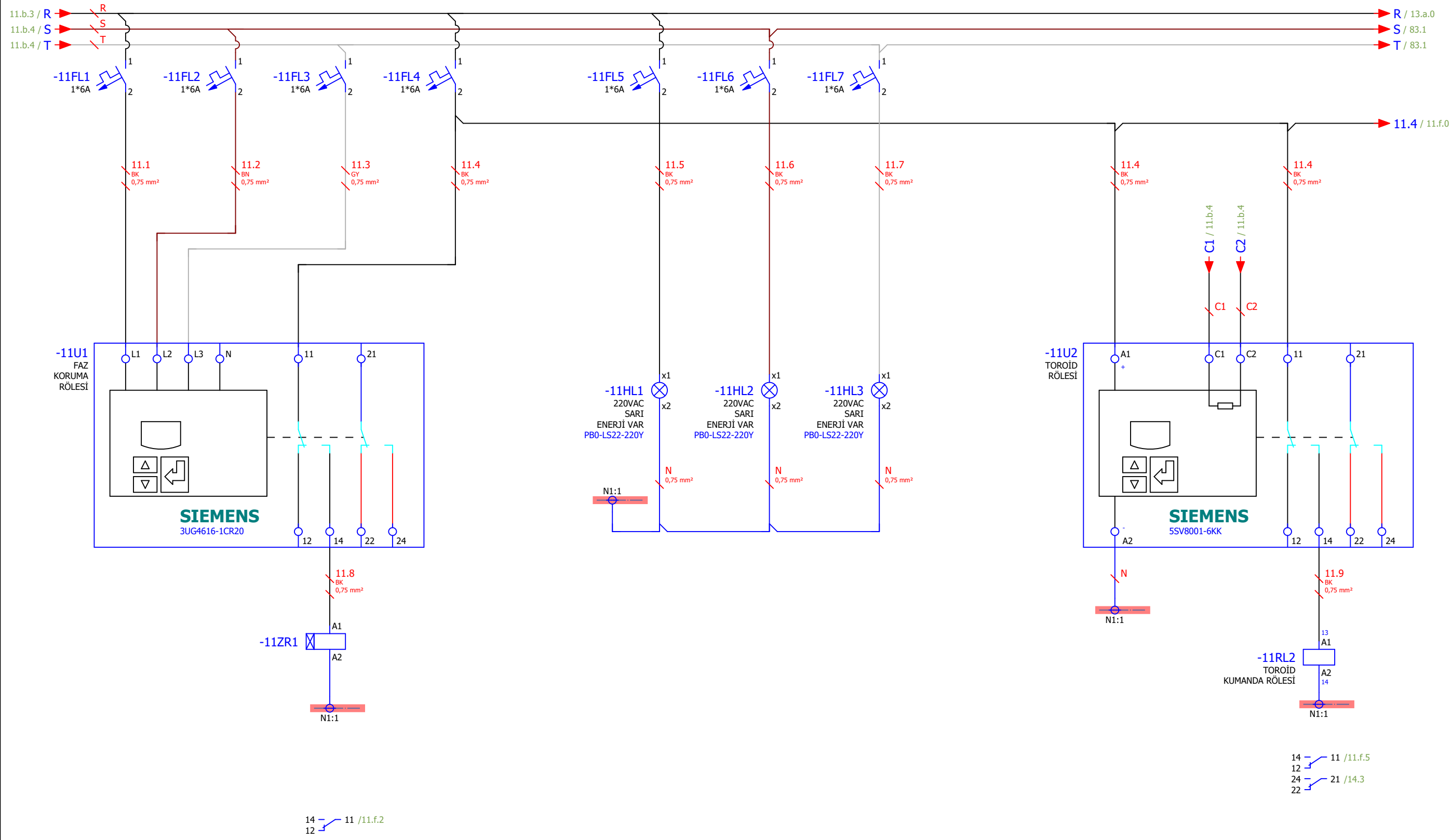

Cizen (Drawing)	Kontrol (Control)	USIA	Kontrol (Control)	esan	Tag Number	Lokasyon	Sayfa açıklaması (Page description)	Proje adı (Project name)	=
Necip SERT Proje Tasarım	Ufuk GÜLÇEN Proje Sorumlusu		Önder KURT Proje Sorumlusu				Ana Şalter Kumanda Devresi - 1	Esan Eczacıbaşı Milas ÜY S YENİ KURUTMA	MCC
									Next page: 11.d
									Previous page: 11.b





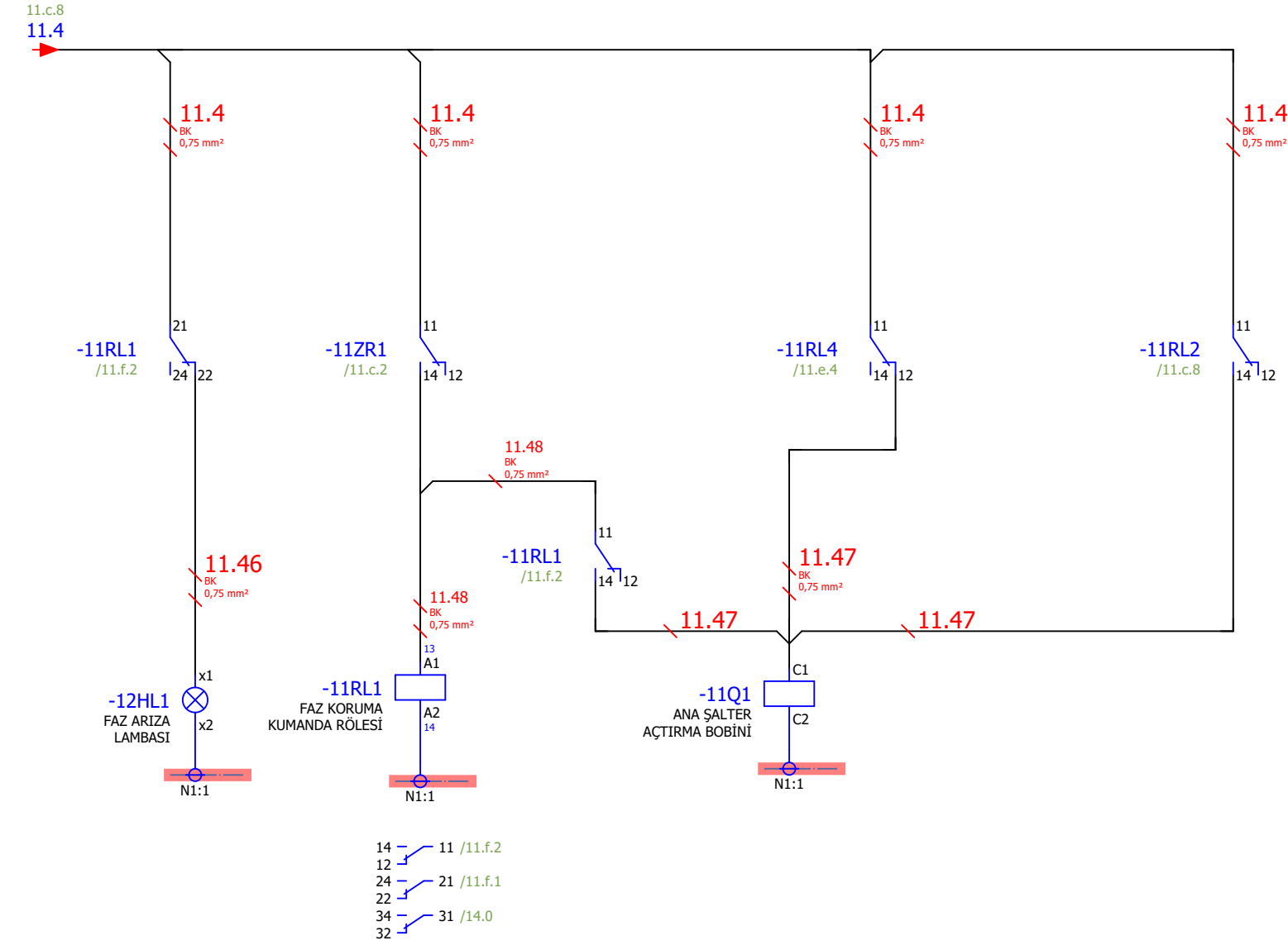

Çizen (Drawing)	Kontrol (Control)	USIA Unique Software at Applications an EPC company	Kontrol (Control)	esan	Tag Number	Lokasyon	Sayfa açıklaması (Page description)	Proje adı (Project name)	=
Necip SERT Proje Tasarım	Ufuk GÜLÇEN Proje Sorumlusu		Önder KURT Proje Sorumlusu				Ana Şalter Kumanda Devresi - 2	Esan Eczacıbaşı Milas ÜYS YENİ KURUTMA	
									+ MCC
									Next page: 13.a
									Previous page: 11.e

## UPS BESLEME

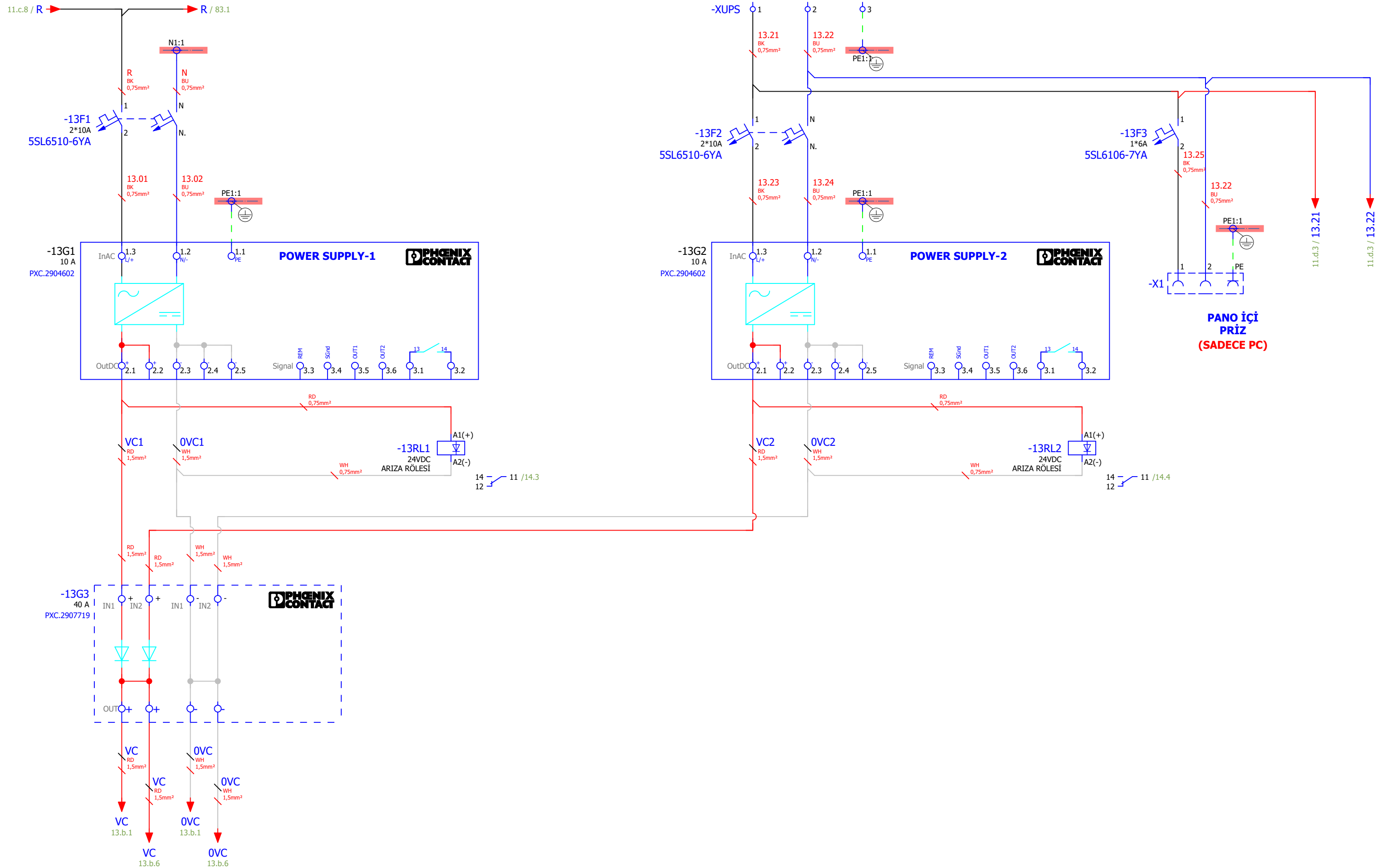

Çizen (Drawing)	Kontrol (Control)	US	Kontrol (Control)	esan	Tag Number	Lokasyon	Sayfa açıklaması (Page description)	Proje adı (Project name)	=
Necip SERT Proje Tasarım	Ufuk GÜLÇEN Proje Sorumlusu		Önder KURT Proje Sorumlusu				Güç Kaynağı	Esan Eczacıbaşı Milas ÜYENİ KURUTMA	MCC
									Next page: 13.b
									Previous page: 11.f





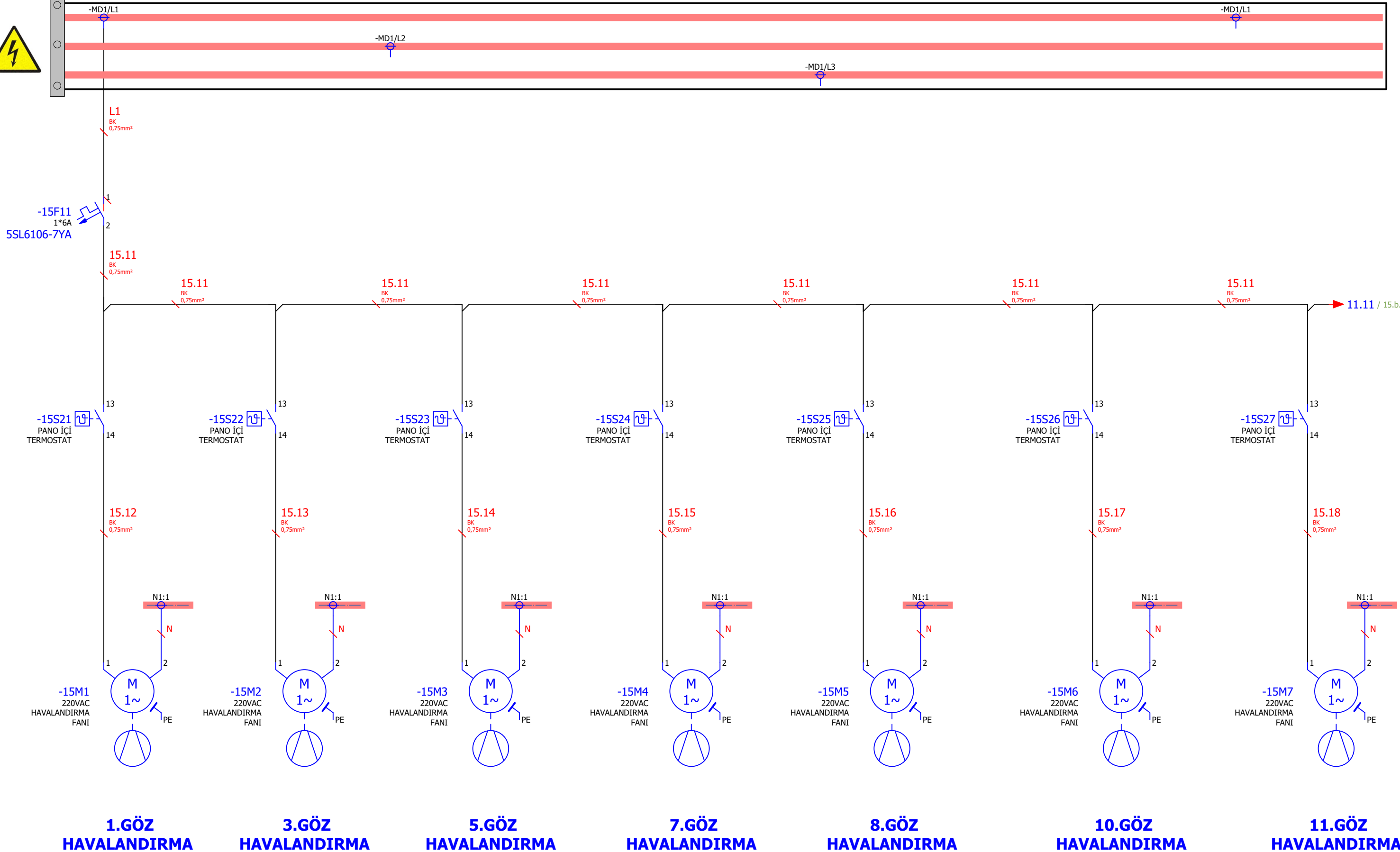

11.11 / 15.b.0

Çizen (Drawing)	Kontrol (Control)
Necip SERT Proje Tasarım	Ufuk GÜLÇEN Proje Sorumlusu



Kontrol (Control)	esan
Önder KURT Proje Sorumlusu	

Tag Number
------------

Lokasyon
----------

Sayfa açıklaması (Page description)
Havalandırma Ve Aydınlatma - 1

Proje adı (Project name)
Esan Eczacıbaşı Milas ÜYŞ YENİ KURUTMA

=
+ MCC
Next page: 15.b
Previous page: 14





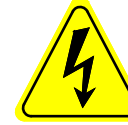

**!!! DİKKAT !!!**  
 MOTOR YOL VERİCİ KORUMA ŞALTERİ  
 HIZ KONTROL (VFD) GÜCÜNE GÖRE SECİLMİŞTİR .  
 MOTOR KORUMA FONKSİYONU  
 HIZ KONTROL (VFD) TARAFINDAN YAPILMAKTADIR .

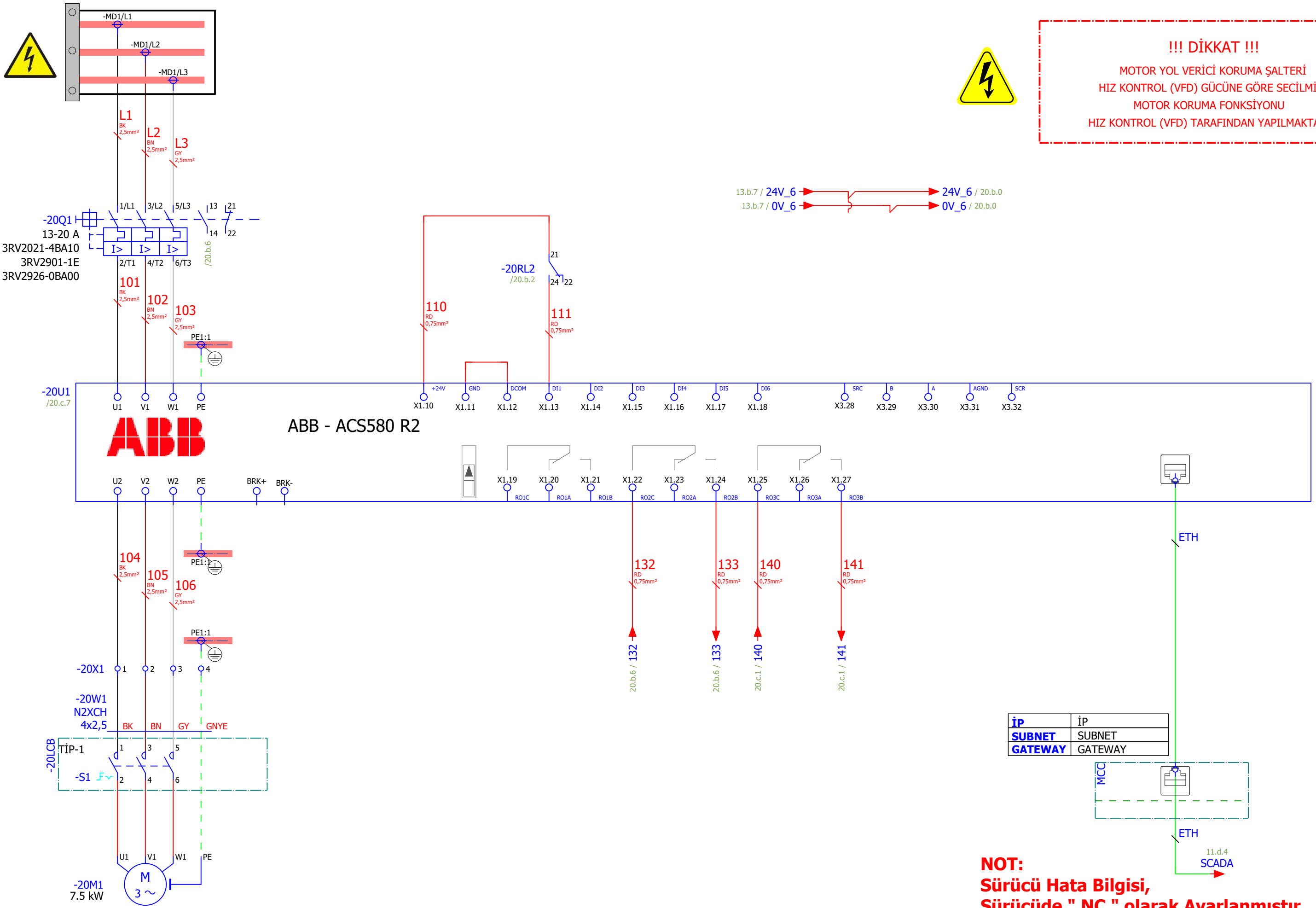

13.b.7 / 24V\_6 → 24V\_6 / 20.b.0  
 13.b.7 / 0V\_6 → 0V\_6 / 20.b.0

İP	İP
SUBNET	SUBNET
GATEWAY	GATEWAY

**NOT:**  
 Sürücü Hata Bilgisi,  
 Sürücüde " NC " olarak Ayarlanmıştır...

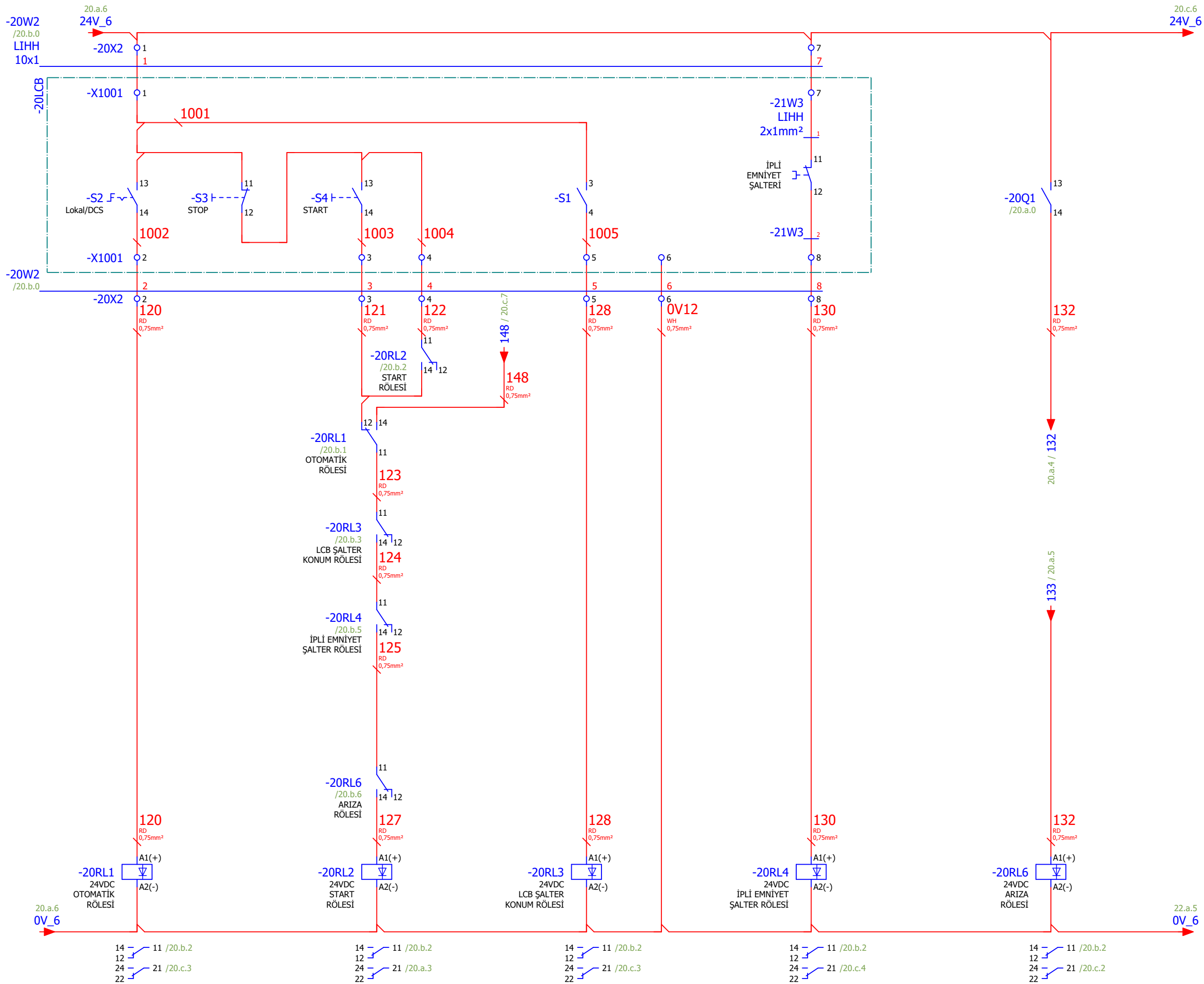

Çizen (Drawing)	Kontrol (Control)	USIA	Kontrol (Control)	Tag Number	Lokasyon	Sayfa açıklaması (Page description)	Proje adı (Project name)	=
Necip SERT Proje Tasarım	Ufuk GÜLÇEN Proje Sorumlusu		Önder KURT Proje Sorumlusu	ESTR-MLS-DRY2-BUN001-xM1-	MCC-6.2	Besleme Bunker Altı Bandı	Esan Eczacıbaşı Milas ÜYS YENİ KURUTMA	MCC
								Next page: 20.c
								Previous page: 20.a

ESTR-MLS-DRY2-BUN001-xM1-  
Besleme Bunker Altı Bandı  
Çalıştı

ESTR-MLS-DRY2-BUN001-xM1-  
Besleme Bunker Altı Bandı  
Arıza



ESTR-MLS-DRY2-BUN001-xM1-  
Besleme Bunker Altı Bandı  
Lokal Remote

ESTR-MLS-DRY2-BUN001-xM1-  
Besleme Bunker Altı Bandı  
Bakım Şalteri

ESTR-MLS-DRY2-BUN001-xM1-  
Besleme Bunker Altı Bandı  
İpli Emniyet Şalteri

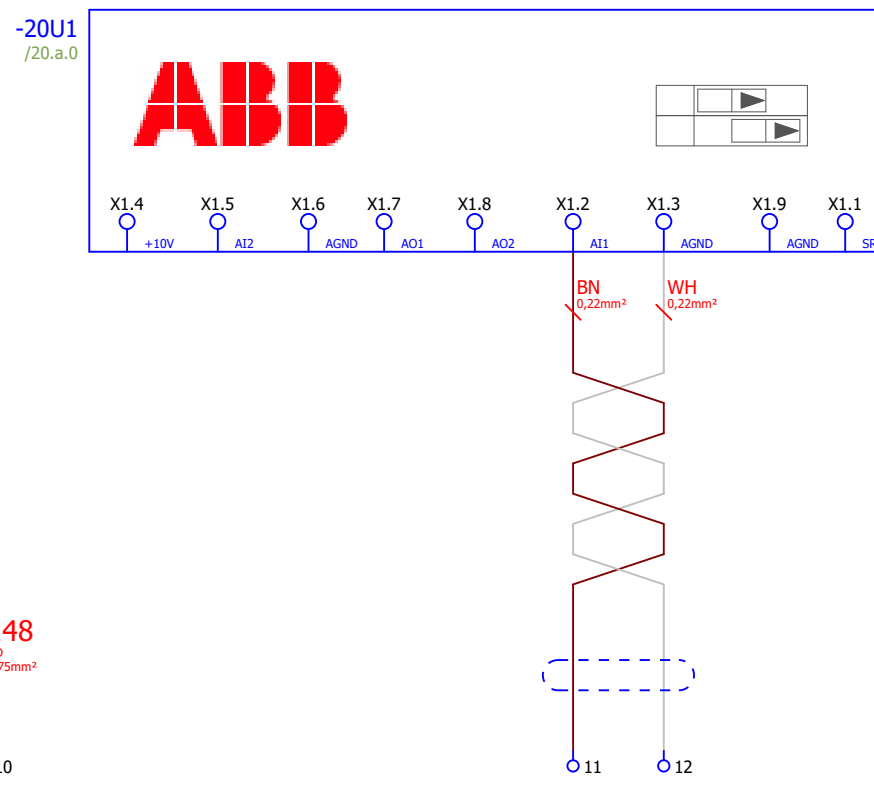
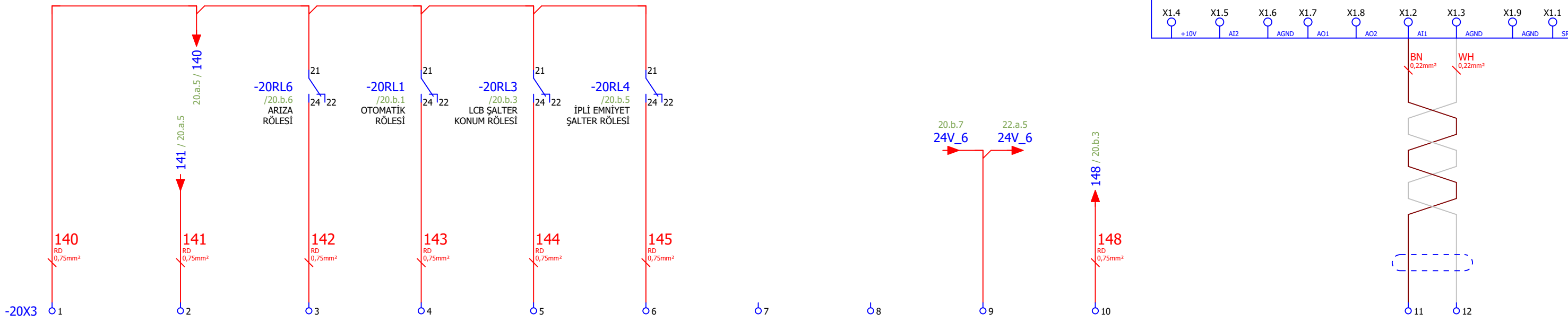
ESTR-MLS-DRY2-BUN001-xM1-  
Besleme Bunker Altı Bandı  
Otomatik Start



Çizen (Drawing)	Kontrol (Control)		Kontrol (Control)		Tag Number	Lokasyon	Sayfa açıklaması (Page description)	Proje adı (Project name)	=
Necip SERT Proje Tasarım	Ufuk GÜLÇEN Proje Sorumlusu		Önder KURT Proje Sorumlusu		ESTR-MLS-DRY2-BUN001-xM1-	MCC-6.2	Besleme Bunker Altı Bandı	Esan Eczacıbaşı Milas ÜYS YENİ KURUTMA	+ Next page: Previous page:

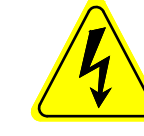
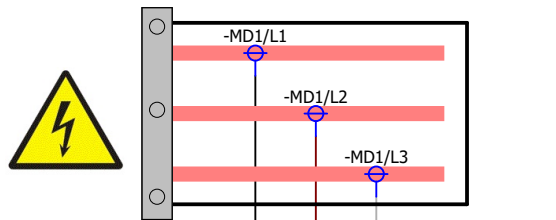

**!!! DİKKAT !!!**  
 MOTOR YOL VERİCİ KORUMA ŞALTERİ  
 HIZ KONTROL (VFD) GÜCÜNE GÖRE SEÇİLMİŞTİR .  
 MOTOR KORUMA FONKSİYONU  
 HIZ KONTROL (VFD) TARAFINDAN YAPILMAKTADIR .

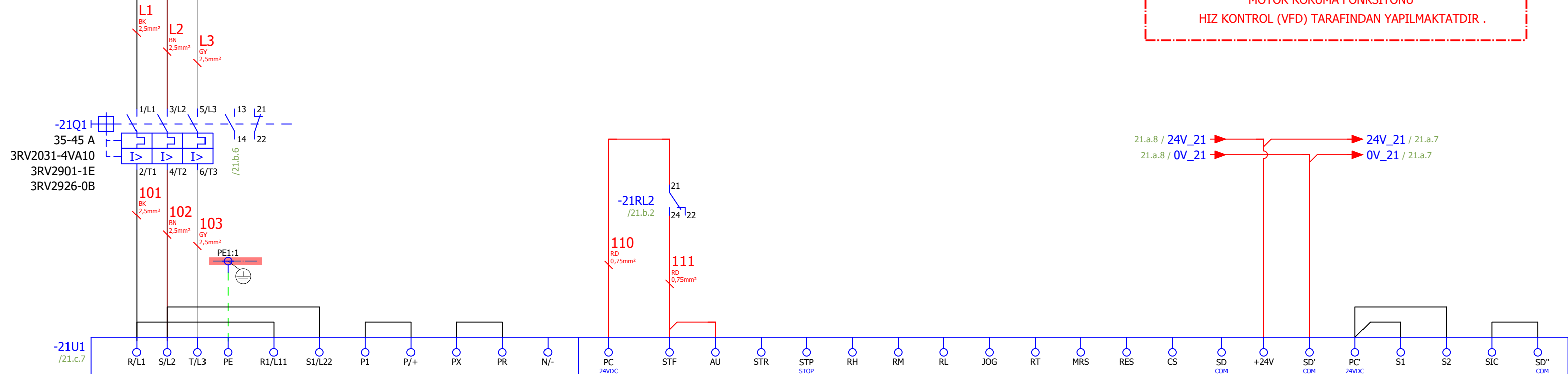

21.a.8 / 24V\_21 → 24V\_21 / 21.a.7  
 21.a.8 / 0V\_21 → 0V\_21 / 21.a.7

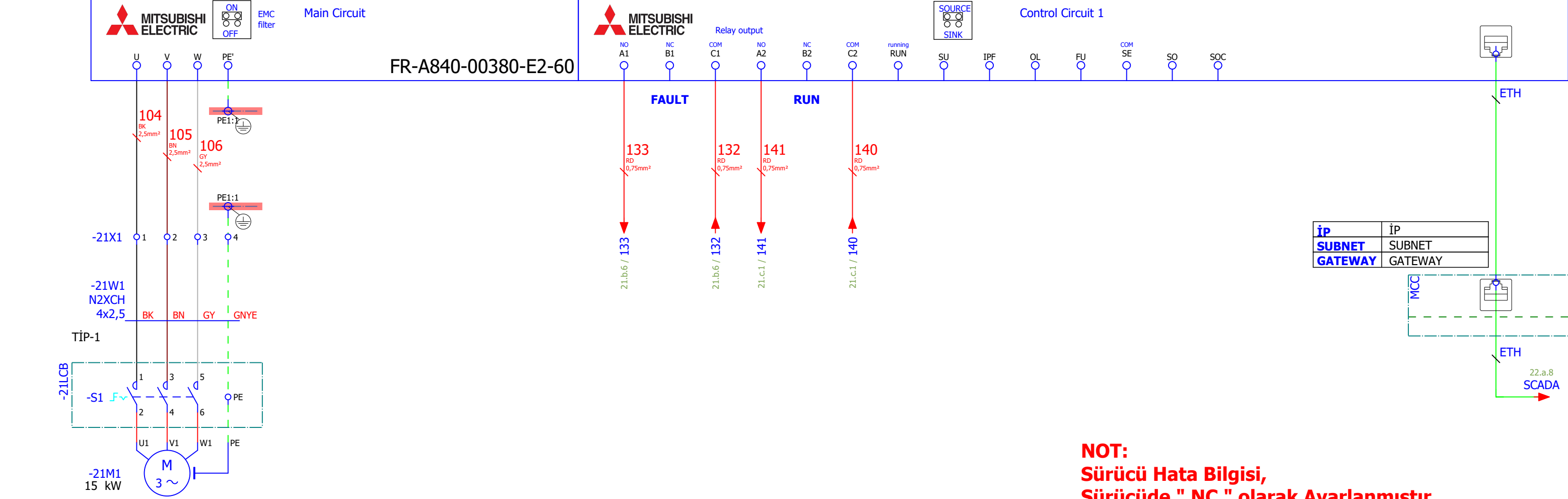

İP	İP
SUBNET	SUBNET
GATEWAY	GATEWAY

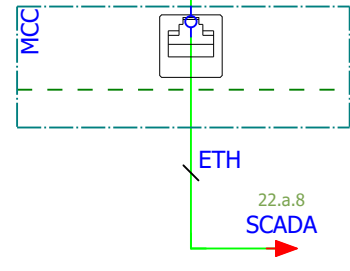

**NOT:**  
 Sürücü Hata Bilgisi,  
 Sürücüde " NC " olarak Ayarlanmıştır...





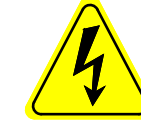
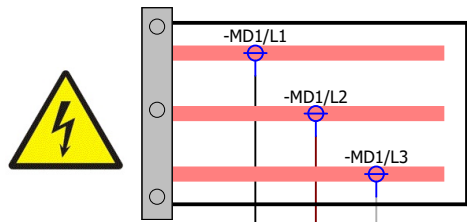

**!!! DİKKAT !!!**  
 MOTOR YOL VERİCİ KORUMA ŞALTERİ  
 HIZ KONTROL (VFD) GÜCÜNE GÖRE SECİLMİŞTİR .  
 MOTOR KORUMA FONKSİYONU  
 HIZ KONTROL (VFD) TARAFINDAN YAPILMAKTADIR .

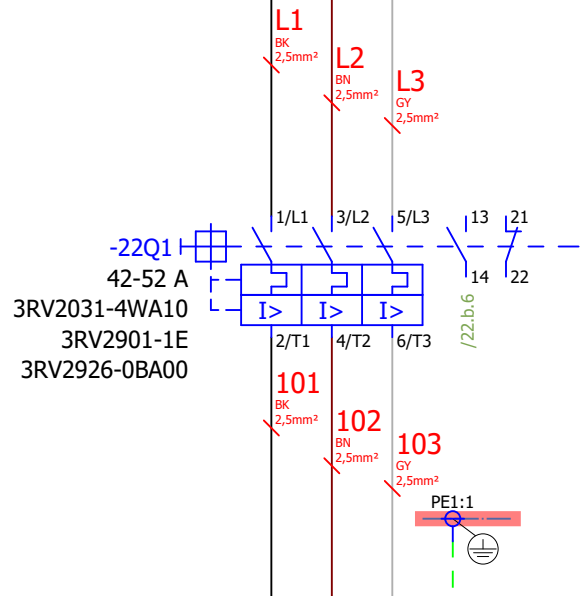

20.c.6 / 24V\_6 → 24V\_6 / 22.b.0  
 20.b.7 / 0V\_6 → 0V\_6 / 22.b.0

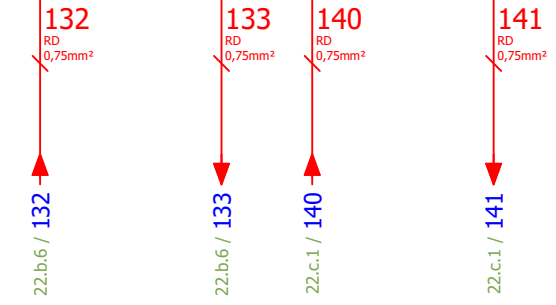
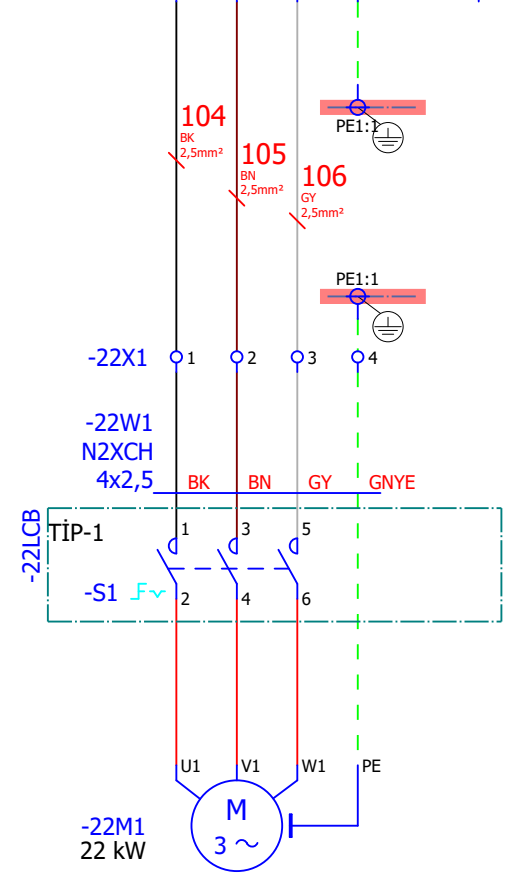
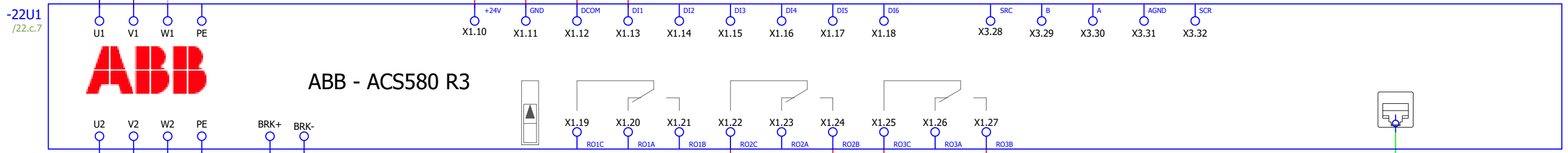
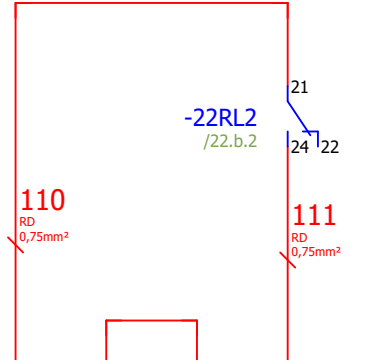

İP	İP
SUBNET	SUBNET
GATEWAY	GATEWAY

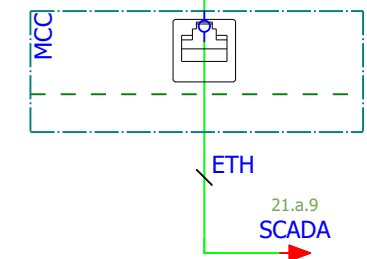

**NOT:**  
 Sürücü Hata Bilgisi,  
 Sürücüde " NC " olarak Ayarlanmıştır...



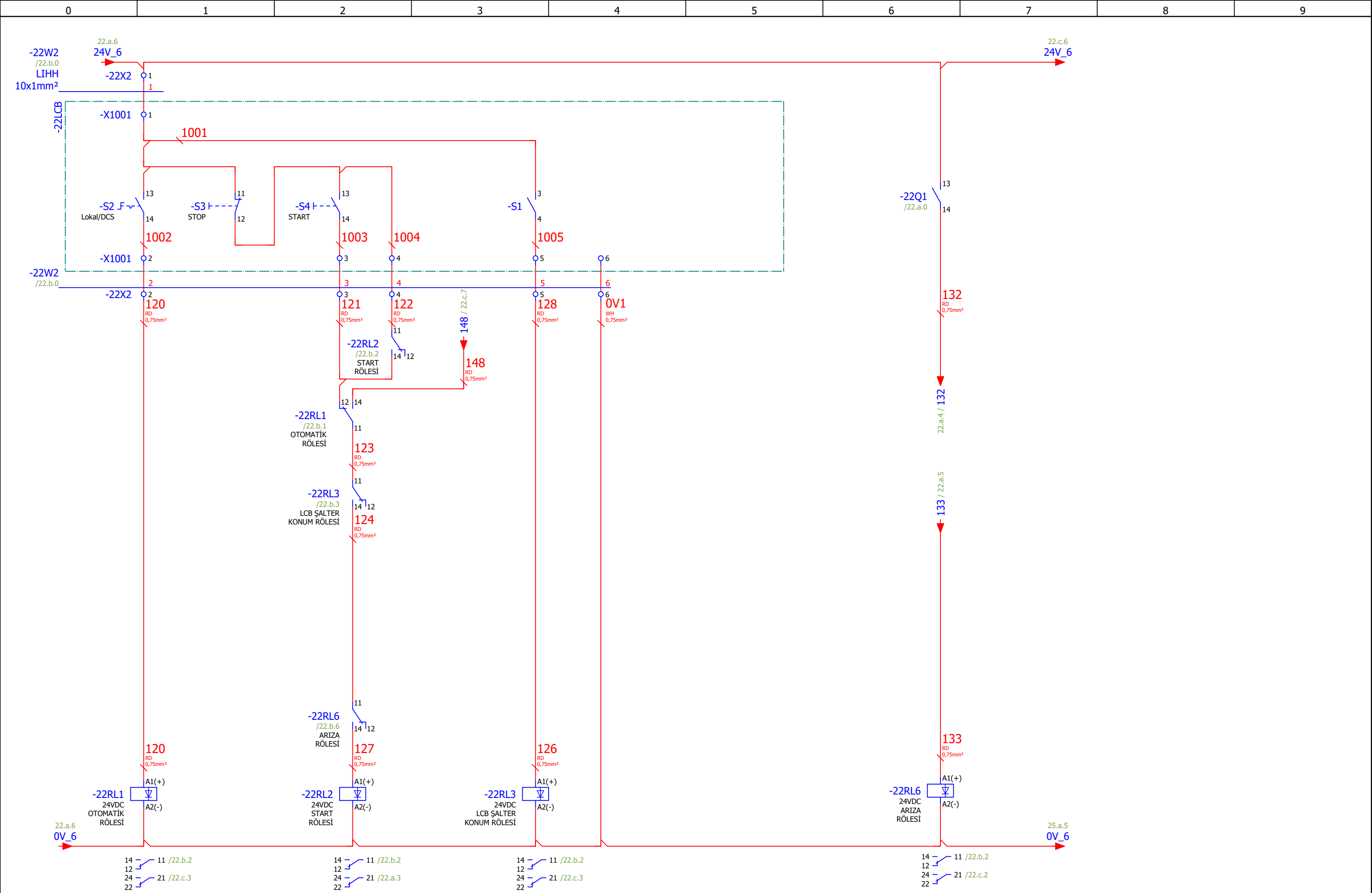

22.a

Page: 22.b

Çizen (Drawing)	Kontrol (Control)	USIA	Kontrol (Control)	Tag Number	Lokasyon	Sayfa açıklaması (Page description)	Proje adı (Project name)	=
Necip SERT Proje Tasarım	Ufuk GÜLÇEN Proje Sorumlusu		Önder KURT Proje Sorumlusu	ESTR-MLS-DRY2-DRY001-xM1	<b>MCC-12.2</b>	Döner Fırın	Esan Eczacıbaşı Milas ÜY YENİ KURUTMA	MCC
								Next page: 22.c
								Previous page: 22.a



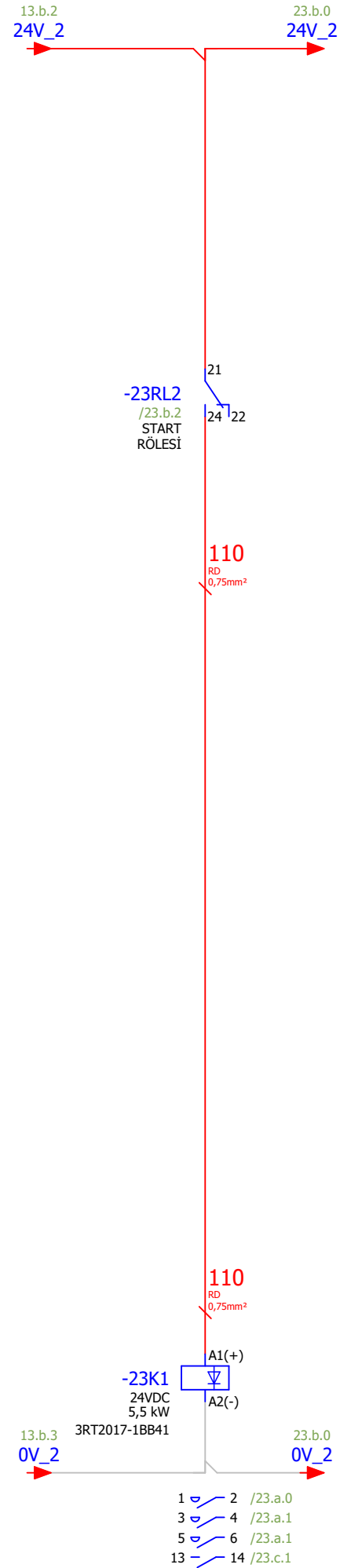
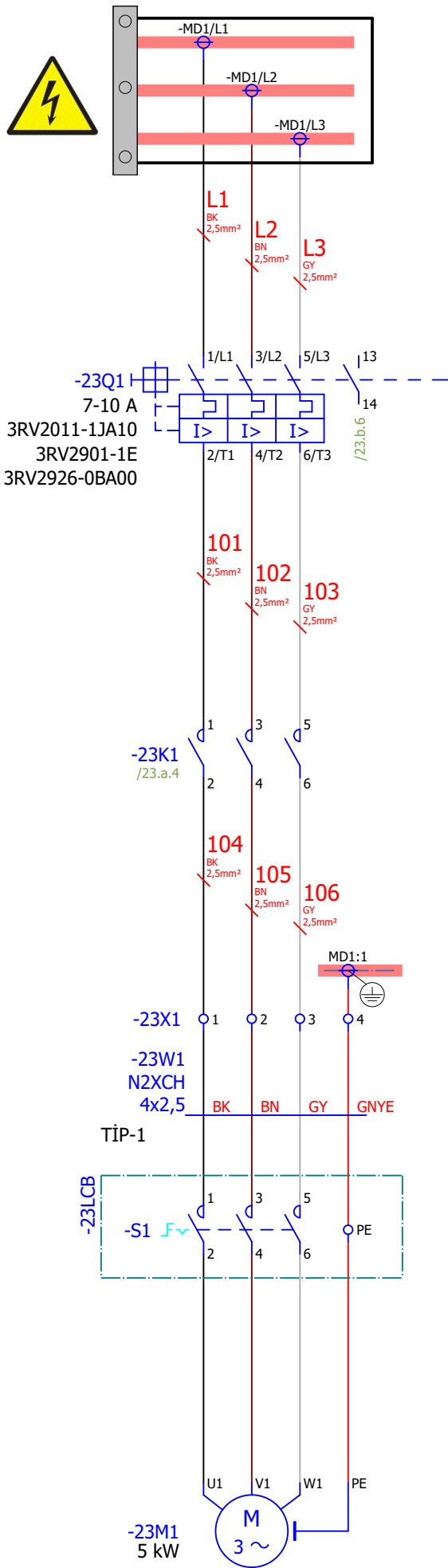

Çizen (Drawing)	Kontrol (Control)	USIA	Kontrol (Control)	esan	Tag Number	Lokasyon	Sayfa açıklaması (Page description)	Proje adı (Project name)	=
Necip SERT Proje Tasarım	Ufuk GÜLÇEN Proje Sorumlusu		Önder KURT Proje Sorumlusu		YEDEK	MCC-2.1	YEDEK	Esan Eczacıbaşı Milas ÜYS YENİ KURUTMA	+ MCC
									Next page: 23.b
									Previous page: 22.c

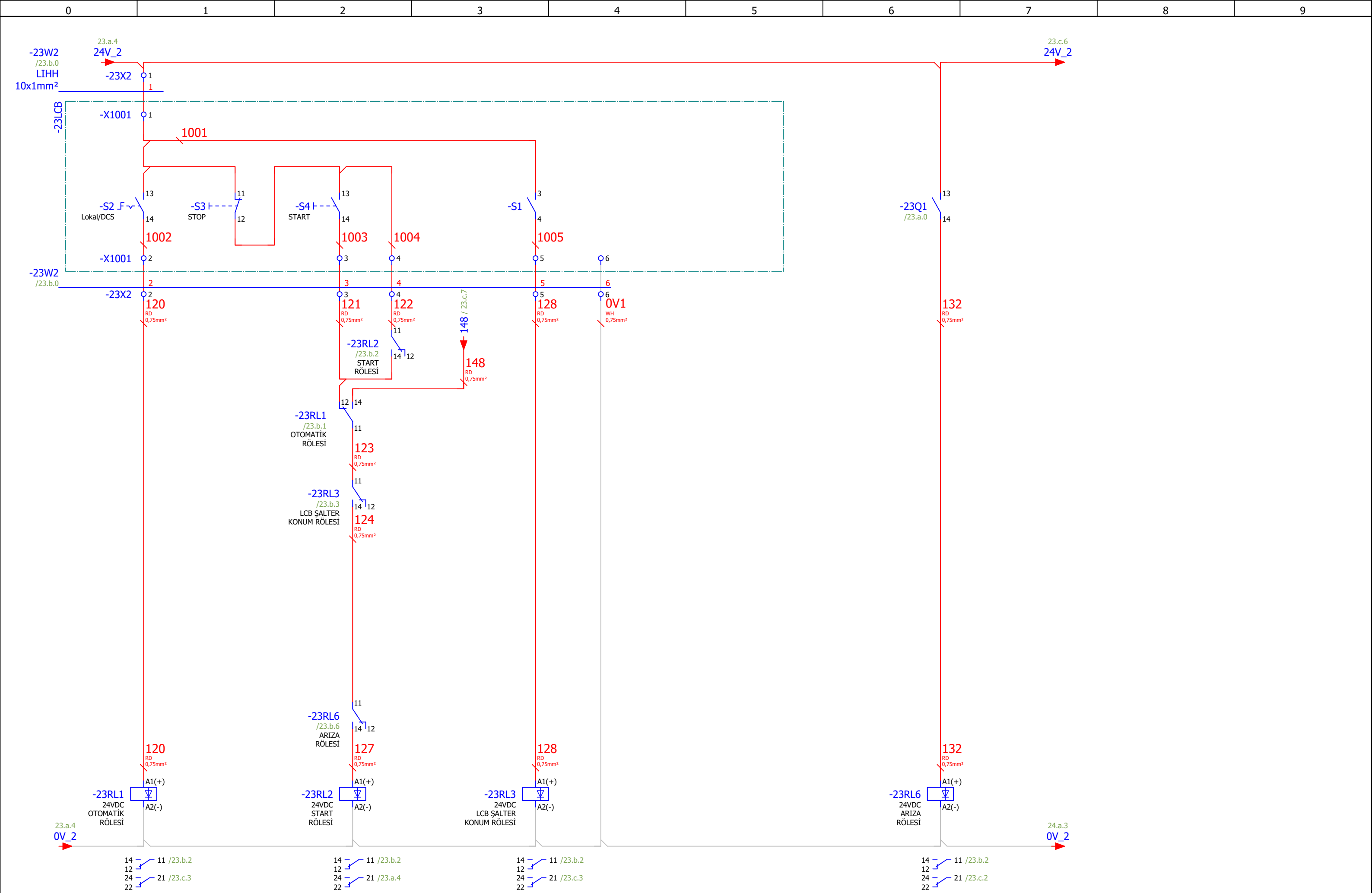

Çizen (Drawing)	Kontrol (Control)	USIA Unique Software at Applications an EPC company	Kontrol (Control)	esan	Tag Number	Lokasyon	Sayfa açıklaması (Page description)	Proje adı (Project name)	=
Necip SERT Proje Tasarım	Ufuk GÜLÇEN Proje Sorumlusu		Önder KURT Proje Sorumlusu		YEDEK	MCC-2.1	YEDEK	Esan Eczacıbaşı Milas ÜYS YENİ KURUTMA	+ MCC

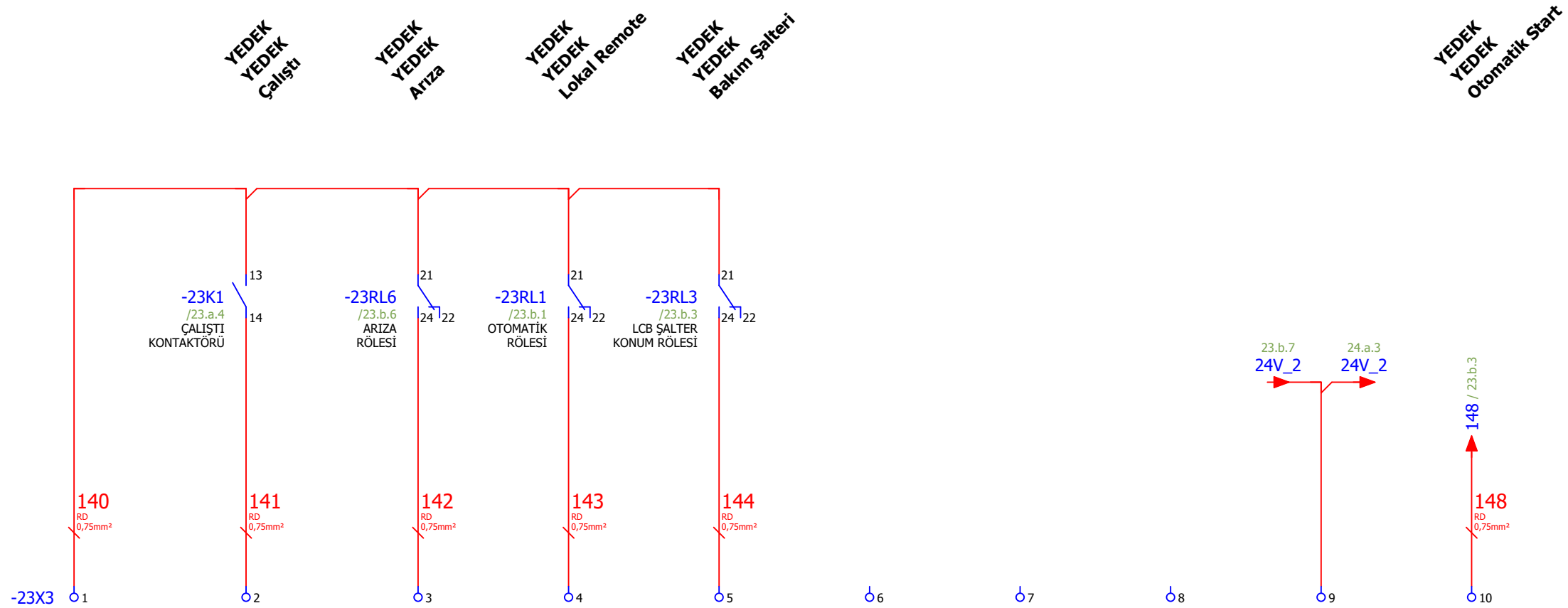

Çizen (Drawing)	Kontrol (Control)	USIA Unique Software at Applications an EPC company	Kontrol (Control)	esan	Tag Number	Lokasyon	Sayfa açıklaması (Page description)	Proje adı (Project name)	=
Necip SERT Proje Tasarım	Ufuk GÜLÇEN Proje Sorumlusu		Önder KURT Proje Sorumlusu		YEDEK	MCC-2.1	YEDEK	Esan Eczacıbaşı Milas ÜYS YENİ KURUTMA	+ MCC









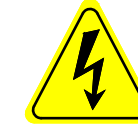

**!!! DİKKAT !!!**  
 MOTOR YOL VERİCİ KORUMA ŞALTERİ  
 HIZ KONTROL (VFD) GÜCÜNE GÖRE SECİLMİŞTİR .  
 MOTOR KORUMA FONKSİYONU  
 HIZ KONTROL (VFD) TARAFINDAN YAPILMAKTADIR .

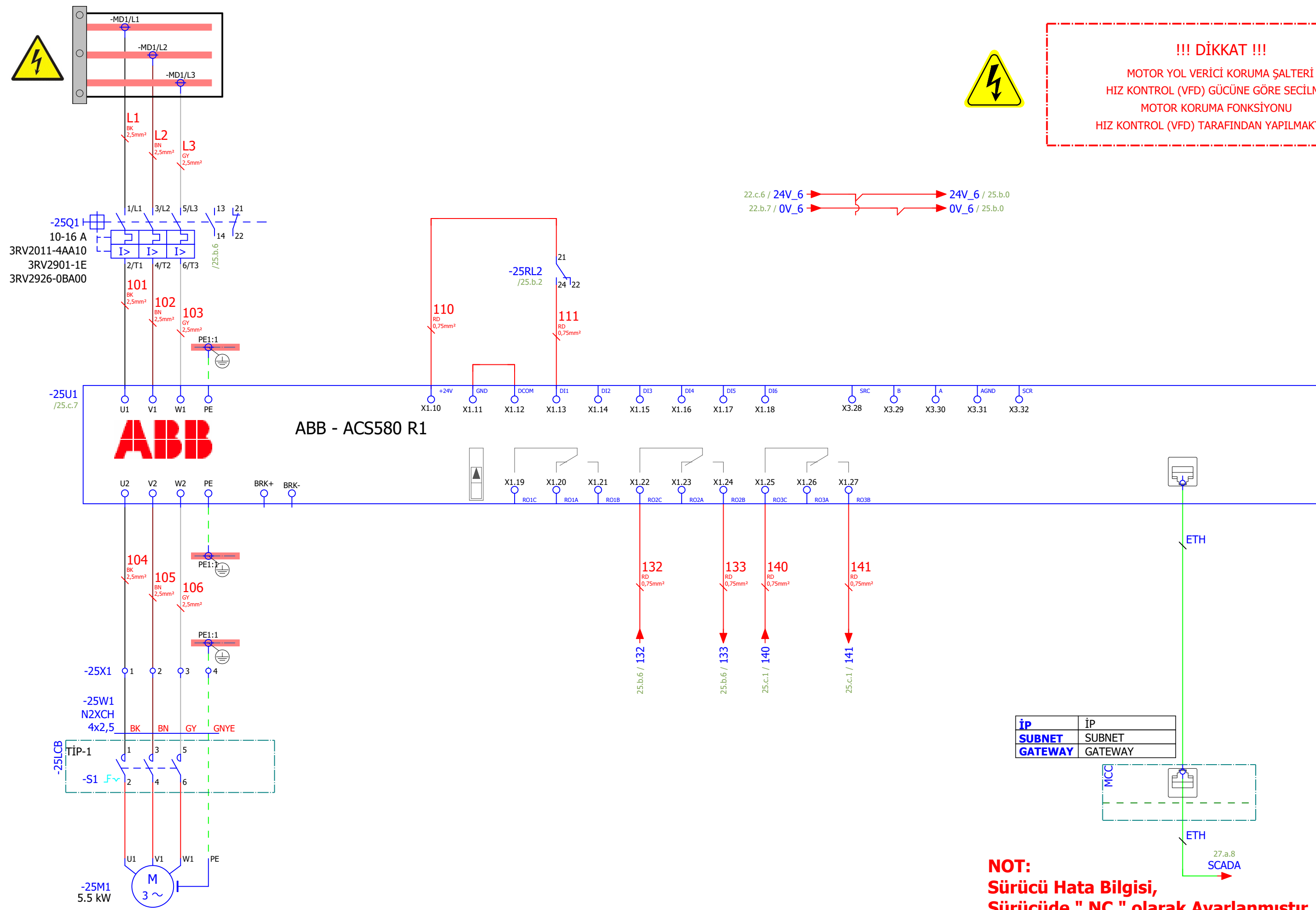

22.c.6 / 24V\_6 → 24V\_6 / 25.b.0  
 22.b.7 / 0V\_6 → 0V\_6 / 25.b.0

İP	İP
SUBNET	SUBNET
GATEWAY	GATEWAY

**NOT:**  
 Sürücü Hata Bilgisi,  
 Sürücüde " NC " olarak Ayarlanmıştır...

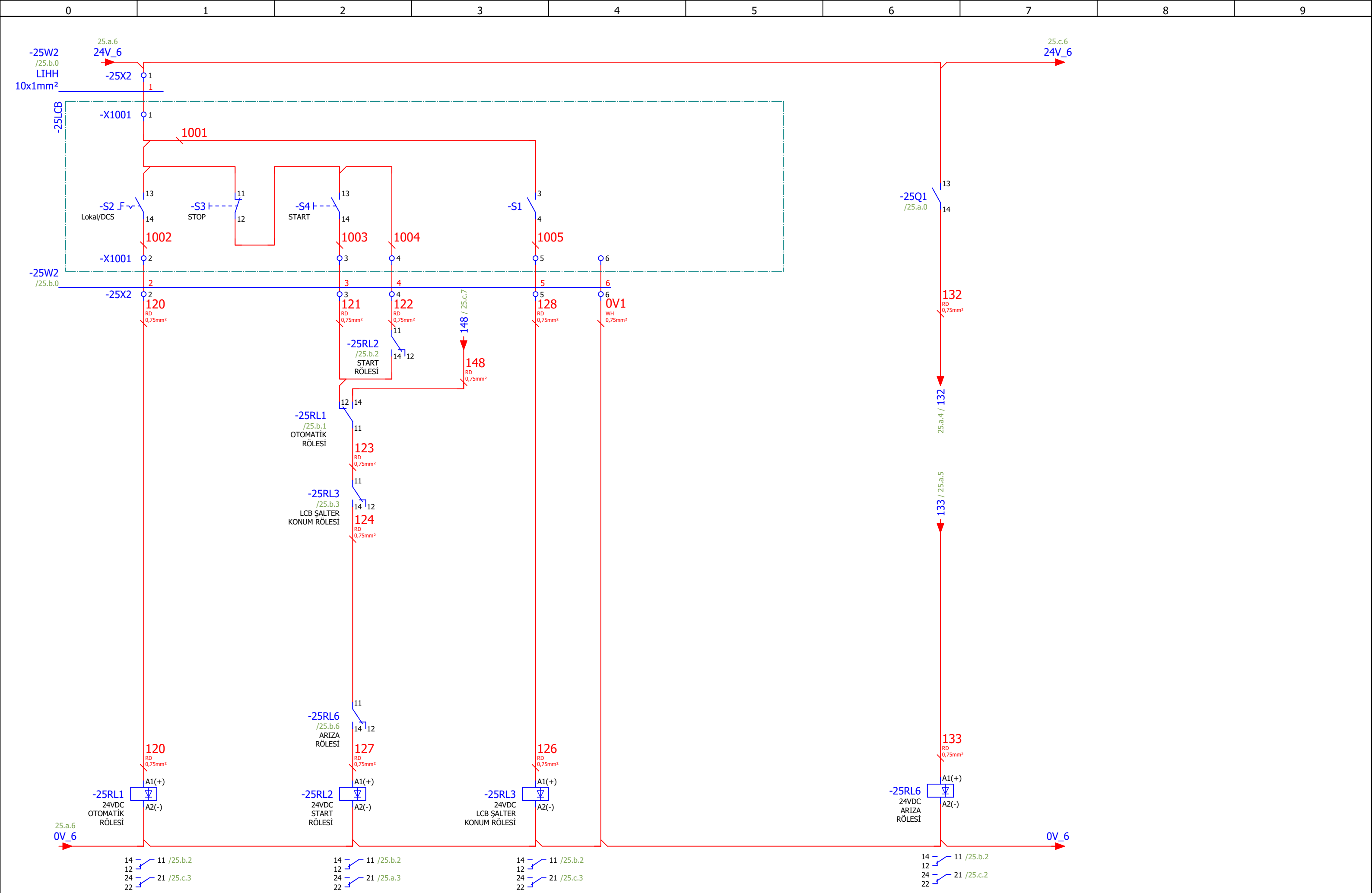

Çizen (Drawing)	Kontrol (Control)	USIA	Kontrol (Control)	Tag Number	Lokasyon	Sayfa açıklaması (Page description)	Proje adı (Project name)
Necip SERT Proje Tasarım	Ufuk GÜLÇEN Proje Sorumlusu		Önder KURT Proje Sorumlusu	ESTR-MLS-DRY2-BLW002-xM2-	MCC-6.1	Sekonder Fan Motoru	Esan Eczacıbaşı Milas ÜY YENİ KURUTMA
=							
+							
Next page: 25.c							
Previous page: 25.a							









**!!! DİKKAT !!!**  
MOTOR YOL VERİCİ KORUMA ŞALTERİ  
HIZ KONTROL (VFD) GÜCÜNE GÖRE SECİLMİŞTİR .  
MOTOR KORUMA FONKSİYONU  
HIZ KONTROL (VFD) TARAFINDAN YAPILMAKTADIR .

27.a.6 / 24V\_13 → 24V\_13 / 27.a.5  
27.a.6 / 0V\_13 → 0V\_13 / 27.a.5

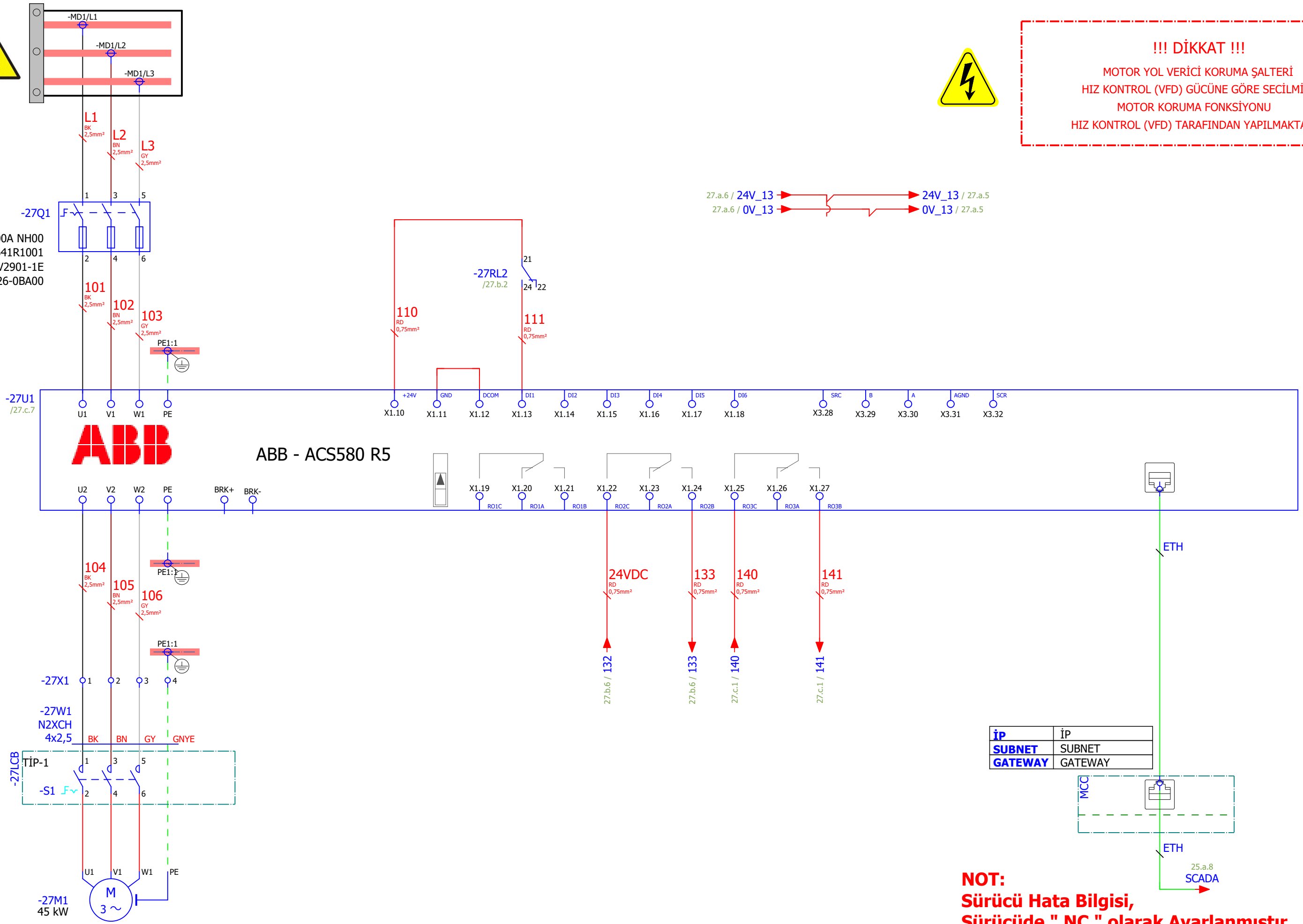

İP	İP
SUBNET	SUBNET
GATEWAY	GATEWAY

**NOT:**  
Sürücü Hata Bilgisi,  
Sürücüde " NC " olarak Ayarlanmıştır...

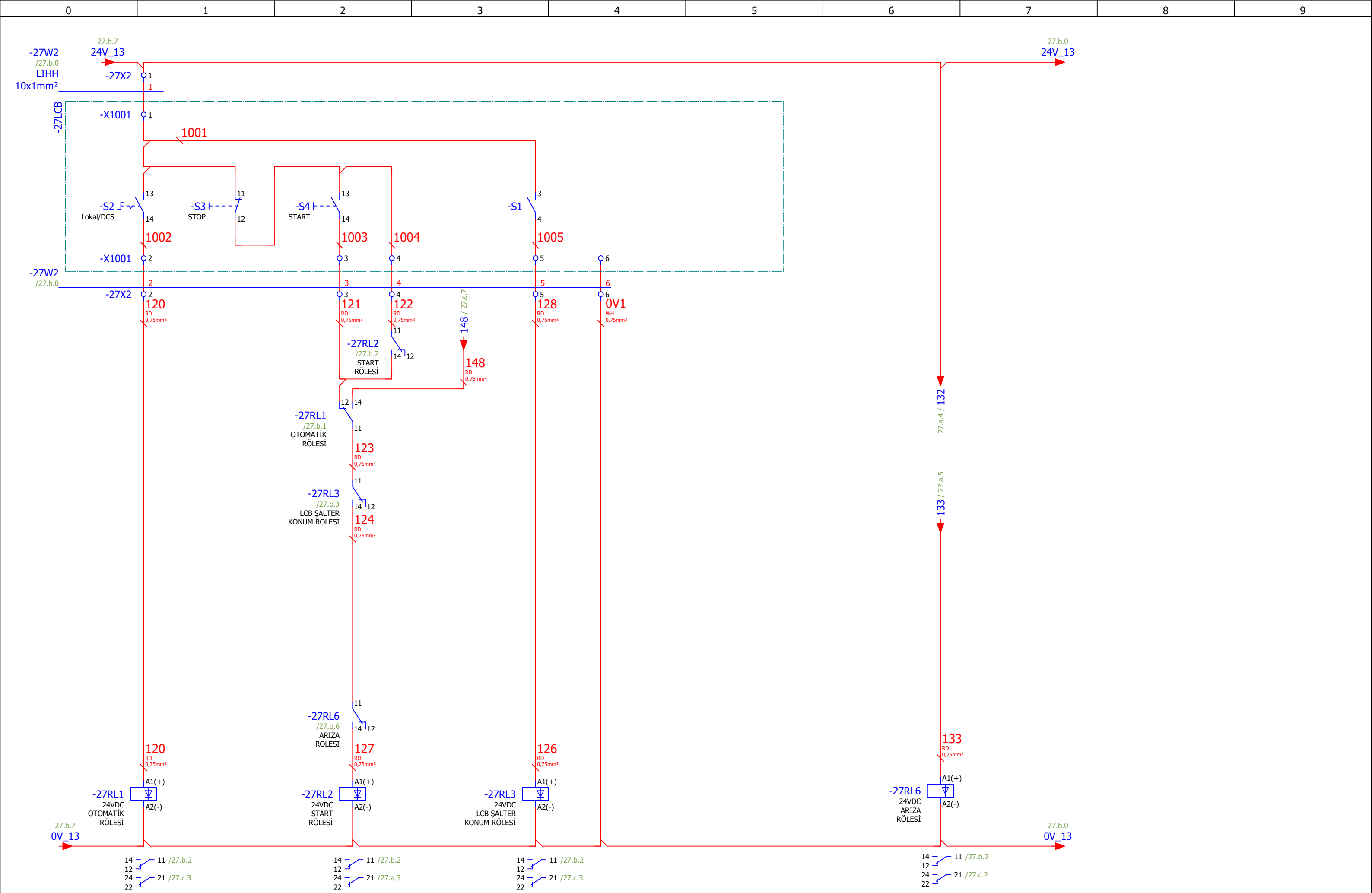

Çizen (Drawing)	Kontrol (Control)	USIA	Kontrol (Control)	Tag Number	Lokasyon	Sayfa açıklaması (Page description)	Proje adı (Project name)	=
Necip SERT Proje Tasarım	Ufuk GÜLÇEN Proje Sorumlusu		Önder KURT Proje Sorumlusu	ESTR-MLS-DRY2-FIL001-xM1	MCC-13	Fırın Filtre Fanı	Esan Eczacıbaşı Milas ÜYİ YENİ KURUTMA	MCC
								Next page: 27.c
								Previous page: 27.a







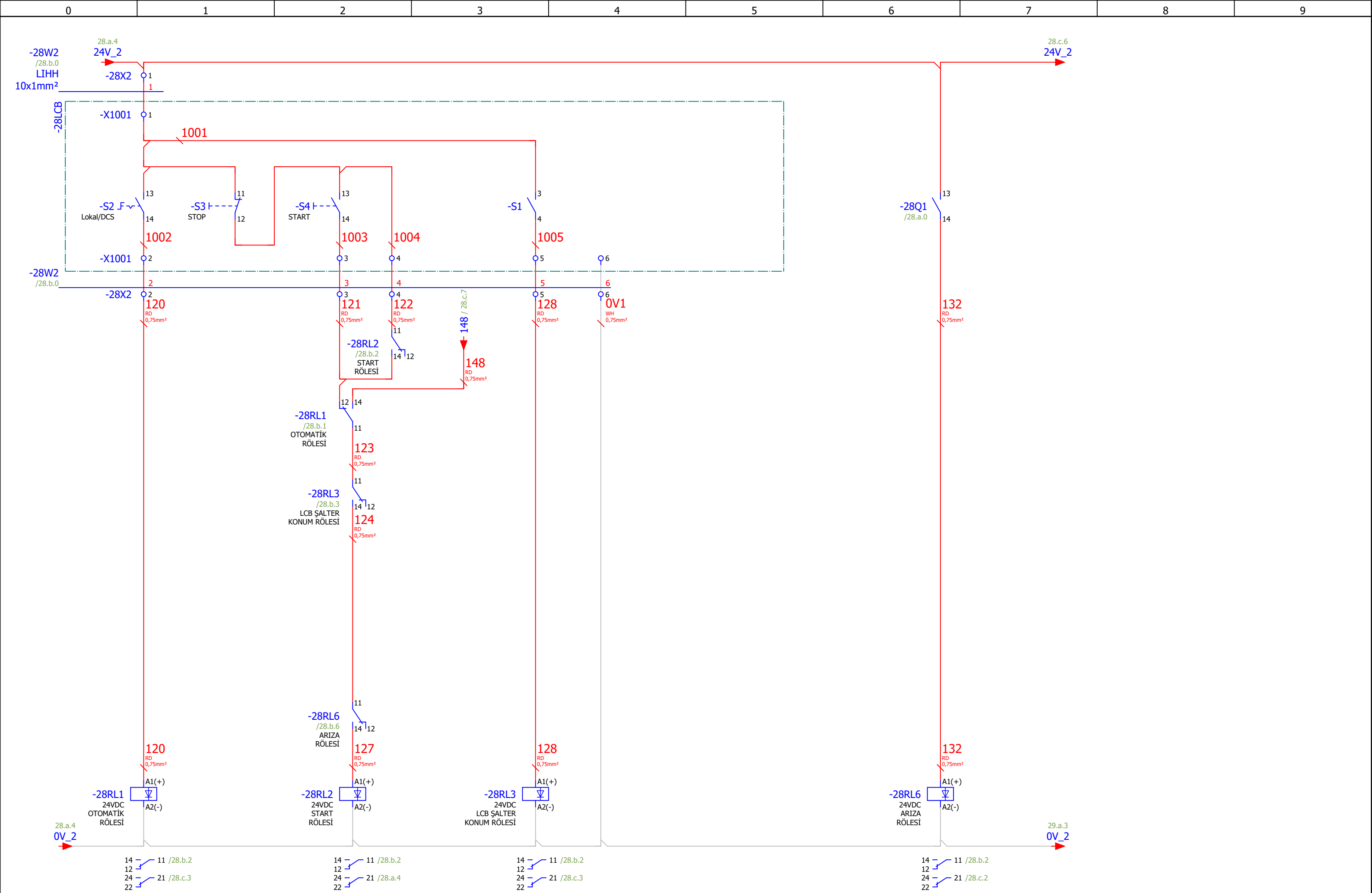

Çizen (Drawing)	Kontrol (Control)	USİA Unique Software at Applications an EPC company	Kontrol (Control)	esan	Tag Number	Lokasyon	Sayfa açıklaması (Page description)	Proje adı (Project name)	=
Necip SERT Proje Tasarım	Ufuk GÜLÇEN Proje Sorumlusu		Önder KURT Proje Sorumlusu		ESTR-MLS-DRY2-VIB005-xM1	MCC-2.3	Fırın Filtre Vidalısı	Esan Eczacıbaşı Milas ÜYS YENİ KURUTMA	
									+ MCC
									Next page: 28.c
									Previous page: 28.a







ESTR-MLS-DRY2-UPS001-Xm1  
Fırın Filtresi Boşaltma Upsider  
Çalıştı

ESTR-MLS-DRY2-UPS001-Xm1  
Fırın Filtresi Boşaltma Upsider  
Arıza

ESTR-MLS-DRY2-UPS001-Xm1  
Fırın Filtresi Boşaltma Upsider  
Lokal Remote

ESTR-MLS-DRY2-UPS001-Xm1  
Fırın Filtresi Boşaltma Upsider  
Bakım Şalteri

ESTR-MLS-DRY2-UPS001-Xm1  
Fırın Filtresi Boşaltma Upsider  
Otomatik Start

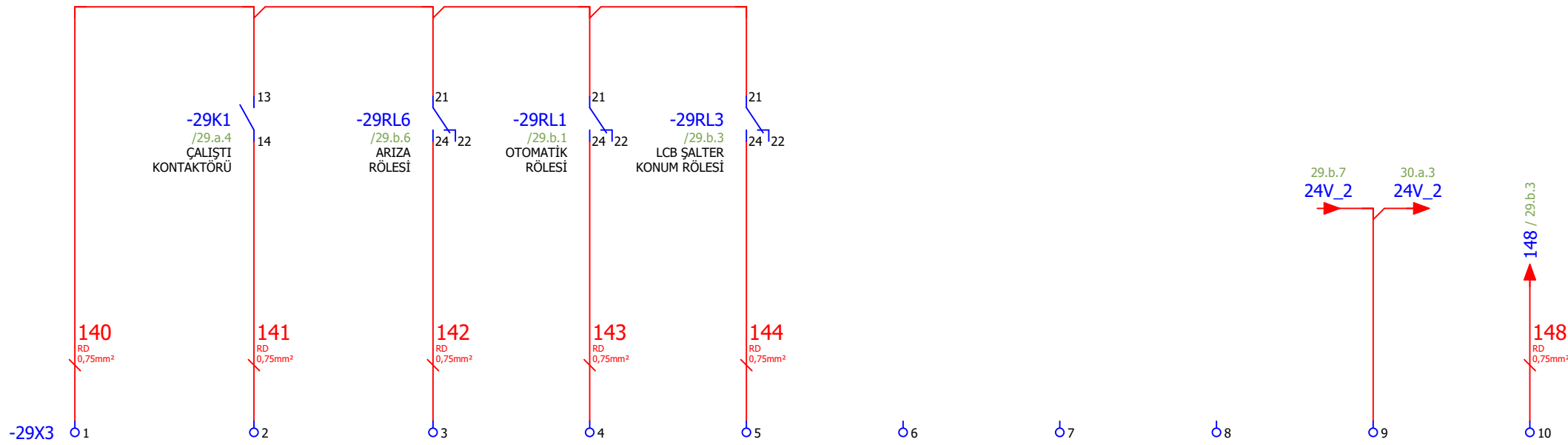

Çizen (Drawing)	Kontrol (Control)	USIA Unique Software at Applications an EPC company	Kontrol (Control)	esan	Tag Number	Lokasyon	Sayfa açıklaması (Page description)	Proje adı (Project name)	=
Necip SERT Proje Tasarım	Ufuk GÜLÇEN Proje Sorumlusu		Önder KURT Proje Sorumlusu		ESTR-MLS-DRY2-UPS001-Xm1	MCC-2.4	Fırın Filtresi Boşaltma Upsider	Esan Eczacıbaşı Milas ÜYS YENİ KURUTMA	+ MCC
									Next page: 30.a
									Previous page: 29.b

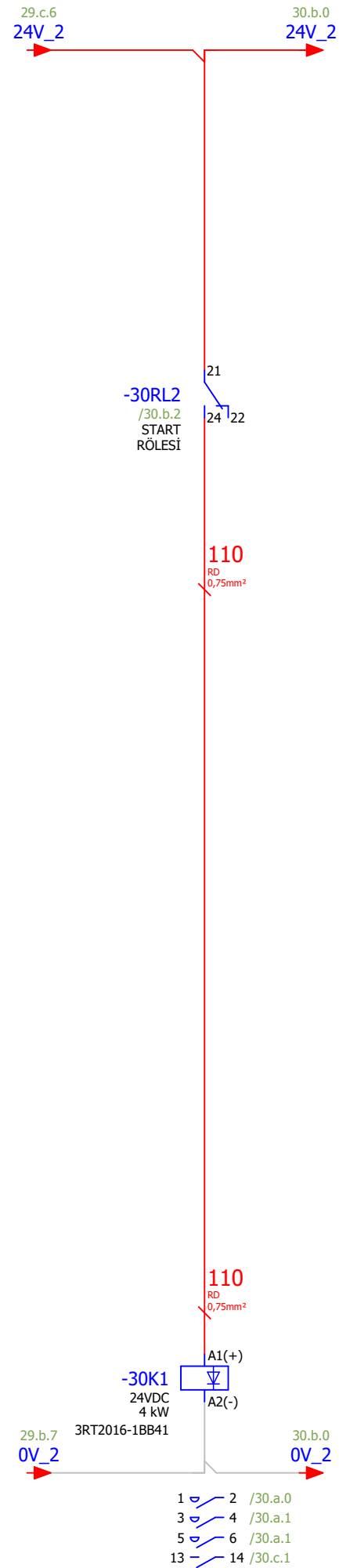
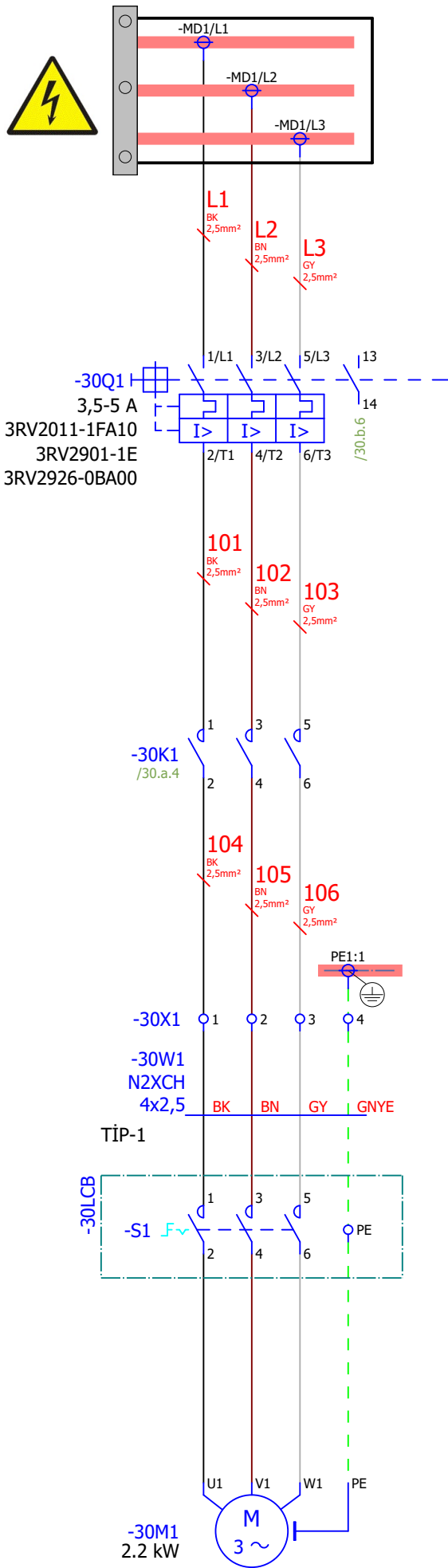

Çizen (Drawing)	Kontrol (Control)	USIA	Kontrol (Control)	esan	Tag Number	Lokasyon	Sayfa açıklaması (Page description)	Proje adı (Project name)	=
Necip SERT Proje Tasarım	Ufuk GÜLÇEN Proje Sorumlusu		Önder KURT Proje Sorumlusu		ESTR-MLS-VIB2-CNV002-xM1-	MCC-2.5	Boşaltma Vidalısı	Esan Eczacıbaşı Milas ÜYS YENİ KURUTMA	
									+ MCC
									Next page: 30.b
									Previous page: 29.c







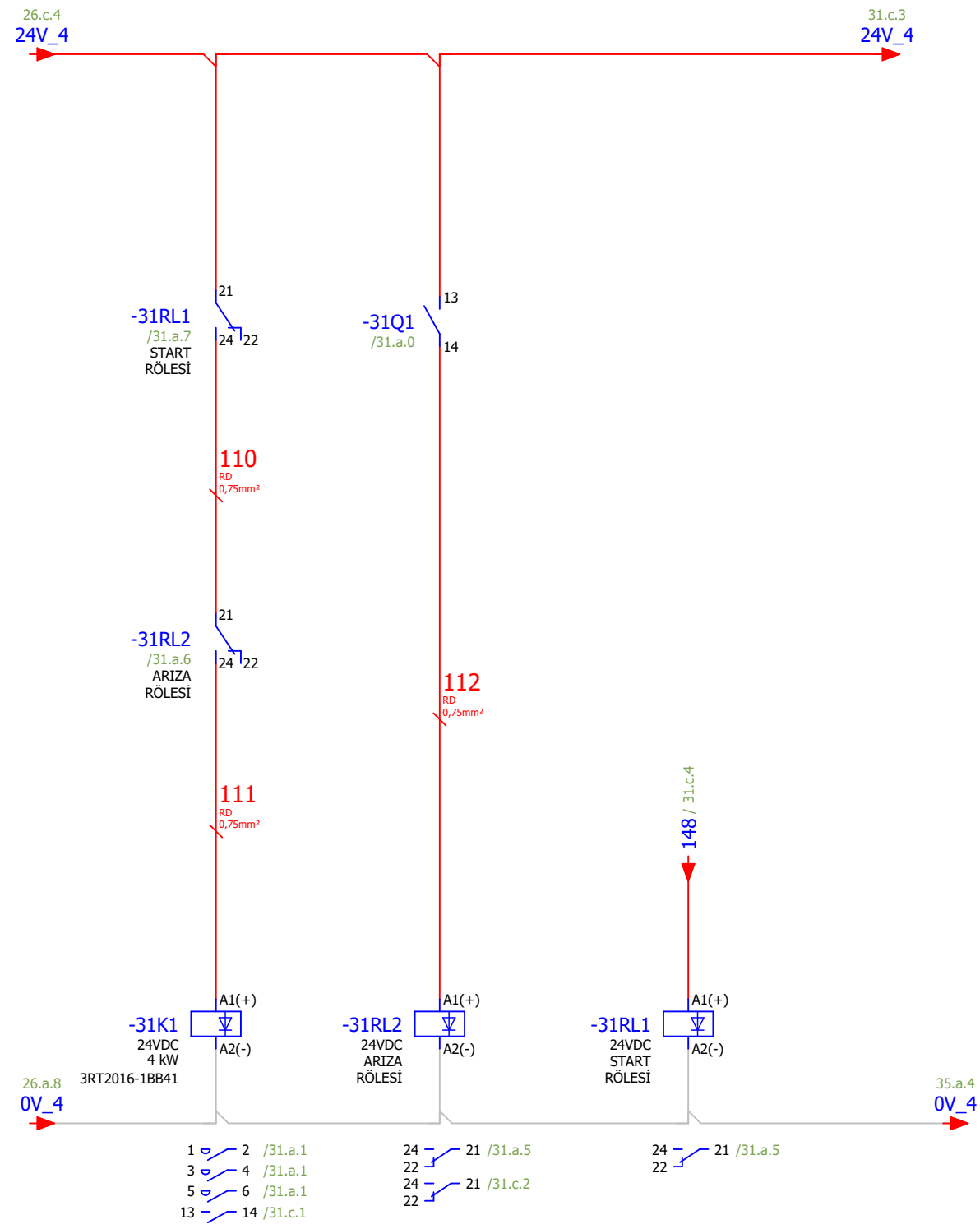
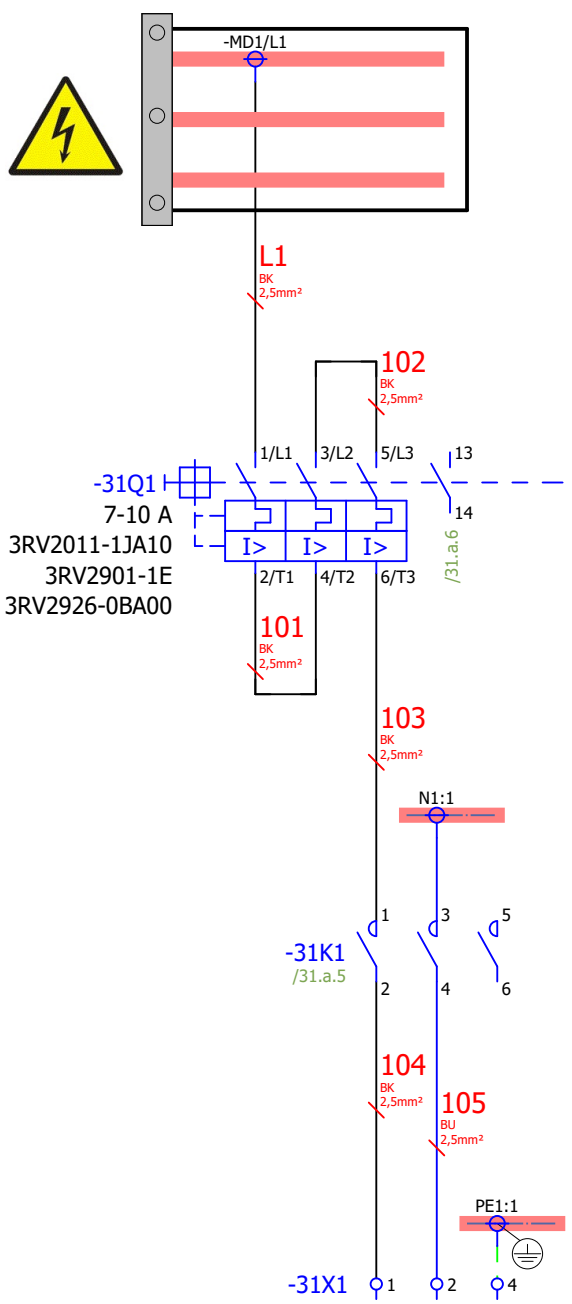

Çizen (Drawing)	Kontrol (Control)
Necip SERT Proje Tasarım	Ufuk GÜLÇEN Proje Sorumlusu

	Kontrol (Control)
	Önder KURT Proje Sorumlusu



Tag Number	ESTR-MLS-KUR2-FIL002-xM2-
------------	---------------------------

Lokasyon	MCC-4.7
----------	---------

Sayfa açıklaması (Page description)	Filtre 2 - Kurutucu Toz Toplama Patlaç
-------------------------------------	--

Proje adı (Project name)	Esan Eczacıbaşı Milas ÜYS YENİ KURUTMA
--------------------------	--

=	
+	MCC
Next page:	31.c
Previous page:	30.c

ESTR-MLS-KUR2-FIL002-xM2-  
Filtre 2 - Kurutucu Toz Toplama Patlaç  
Çalıştı

ESTR-MLS-KUR2-FIL002-xM2-  
Filtre 2 - Kurutucu Toz Toplama Patlaç  
Arıza

ESTR-MLS-KUR2-FIL002-xM2-  
Filtre 2 - Kurutucu Toz Toplama Patlaç  
Otomatik Start

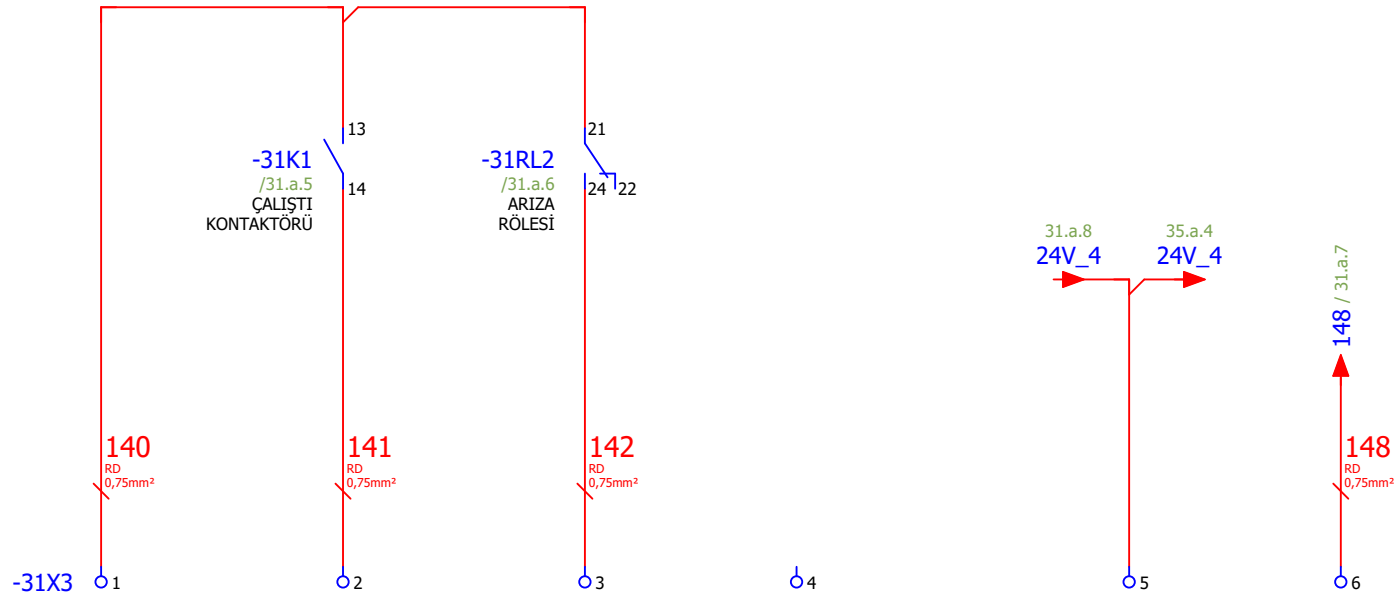

Çizen (Drawing)	Kontrol (Control)	USIA Unique Software at Applications an EPC company	Kontrol (Control)	esan	Tag Number	Lokasyon	Sayfa açıklaması (Page description)	Proje adı (Project name)	=
Necip SERT Proje Tasarım	Ufuk GÜLÇEN Proje Sorumlusu		Önder KURT Proje Sorumlusu		ESTR-MLS-KUR2-FIL002-xM2-	<b>MCC-4.7</b>	Filtre 2 - Kurutucu Toz Toplama Patlaç	Esan Eczacıbaşı Milas ÜYS YENİ KURUTMA	
									+
									Next page:
									Previous page:



**!!! DİKKAT !!!**  
 MOTOR YOL VERİCİ KORUMA ŞALTERİ  
 HIZ KONTROL (VFD) GÜCÜNE GÖRE SECİLMİŞTİR .  
 MOTOR KORUMA FONKSİYONU  
 HIZ KONTROL (VFD) TARAFINDAN YAPILMAKTADIR .

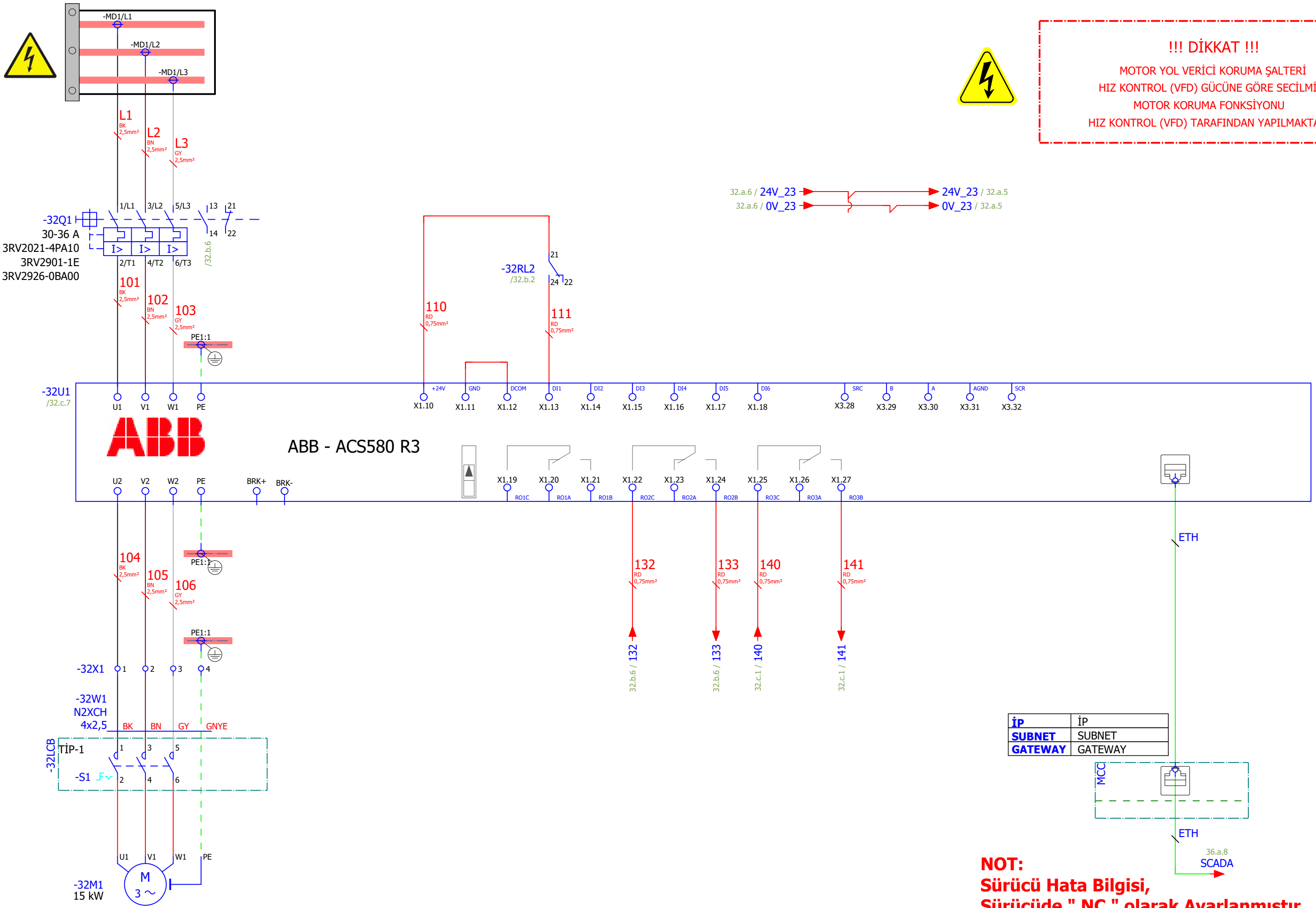

32.a.6 / 24V\_23 → 24V\_23 / 32.a.5  
 32.a.6 / 0V\_23 → 0V\_23 / 32.a.5

İP	İP
SUBNET	SUBNET
GATEWAY	GATEWAY

**NOT:**  
 Sürücü Hata Bilgisi,  
 Sürücüde " NC " olarak Ayarlanmıştır...

Çizen (Drawing)	Kontrol (Control)
Necip SERT Proje Tasarım	Ufuk GÜLÇEN Proje Sorumlusu



Kontrol (Control)
Önder KURT Proje Sorumlusu



Tag Number
ESTR-MLS-DRY2-FAN005-xM1

Lokasyon
<b>MCC-23.1</b>

Sayfa açıklaması (Page description)
Toz Emiş Filtre Fanı

Proje adı (Project name)
Esan Eczacıbaşı Milas ÜYS YENİ KURUTMA

=
+ MCC
Next page: 32.b
Previous page: 31.c

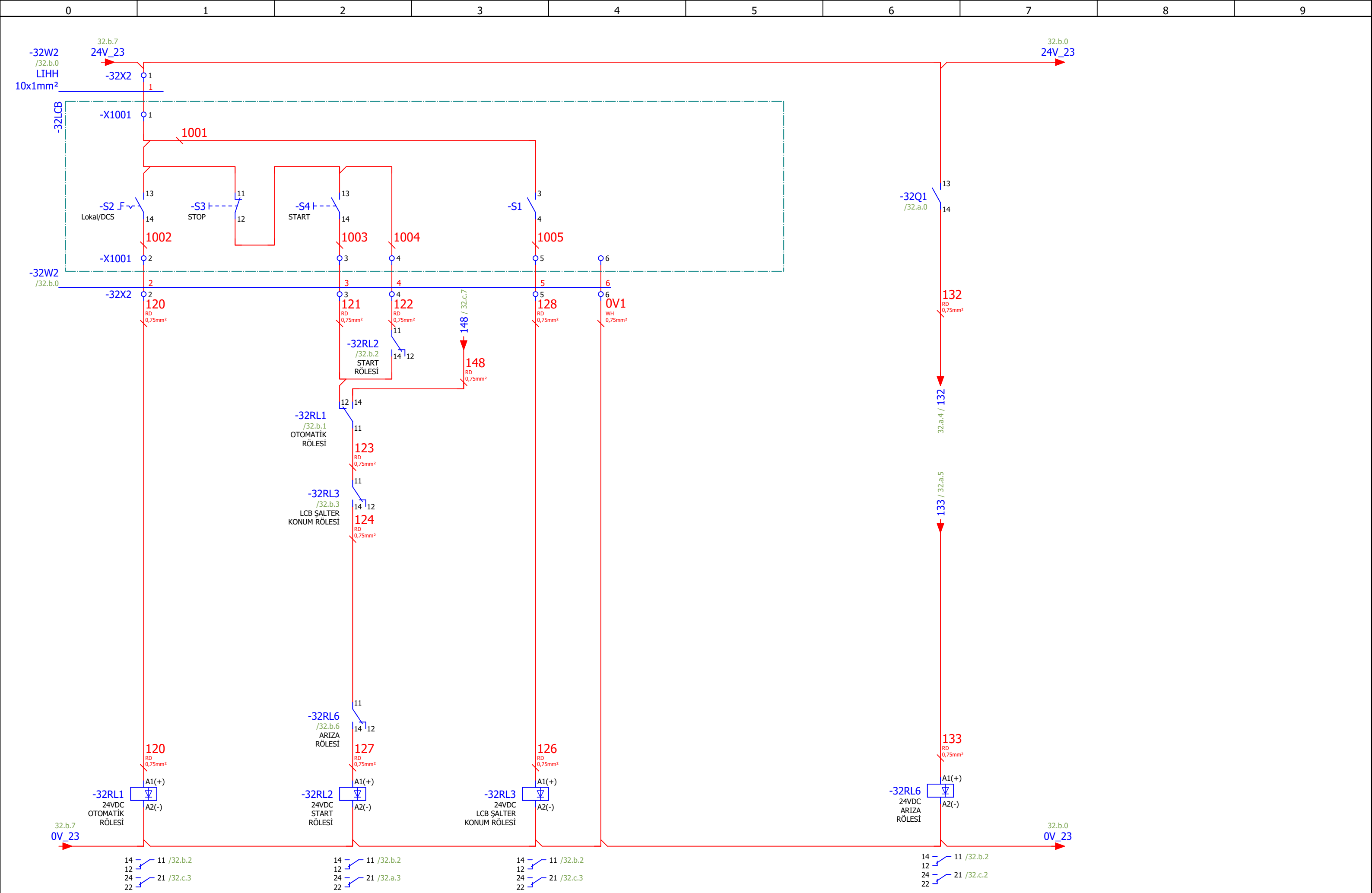

32.a

Page: 32.b

Çizen (Drawing)	Kontrol (Control)	USIA	Kontrol (Control)	Tag Number	Lokasyon	Sayfa açıklaması (Page description)	Proje adı (Project name)	=
Necip SERT Proje Tasarım	Ufuk GÜLÇEN Proje Sorumlusu		Önder KURT Proje Sorumlusu	ESTR-MLS-DRY2-FAN005-xM1	MCC-23.1	Toz Emiş Filtre Fanı	Esan Eczacıbaşı Milas ÜYS YENİ KURUTMA	MCC
								Next page: 32.c
								Previous page: 32.a

ESTR-MLS-DRY2-FAN005-xM1  
Toz Emiş Filtre Fanı  
Çalıştı



ESTR-MLS-DRY2-FAN005-xM1  
Toz Emiş Filtre Fanı  
Arıza

ESTR-MLS-DRY2-FAN005-xM1  
Toz Emiş Filtre Fanı  
Lokal Remote

ESTR-MLS-DRY2-FAN005-xM1  
Toz Emiş Filtre Fanı  
Bakım Şalteri

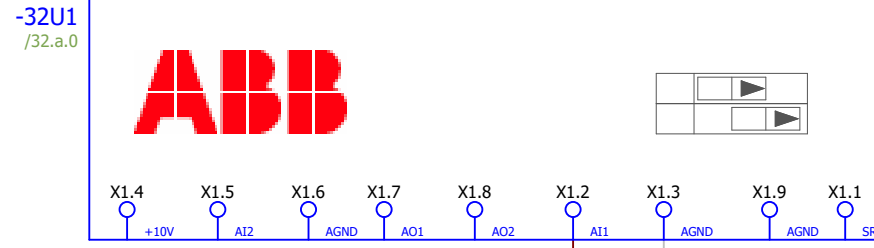
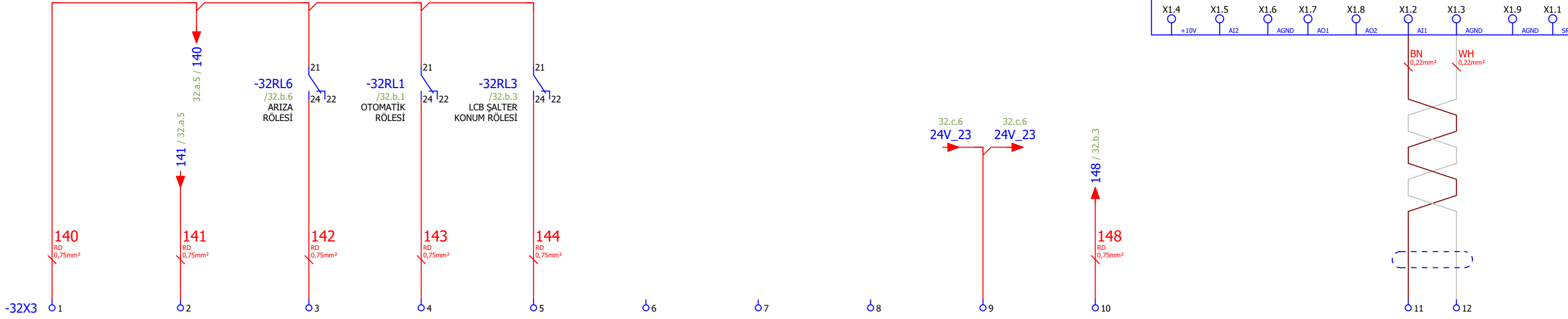
ESTR-MLS-DRY2-FAN005-xM1  
Toz Emiş Filtre Fanı  
Otomatik Start



Çizen (Drawing)	Kontrol (Control)		Kontrol (Control)		Tag Number	Lokasyon	Sayfa açıklaması (Page description)	Proje adı (Project name)	=
Necip SERT Proje Tasarım	Ufuk GÜLÇEN Proje Sorumlusu		Önder KURT Proje Sorumlusu		ESTR-MLS-DRY2-FAN005-xM1	MCC-23.1	Toz Emiş Filtre Fanı	Esan Eczacıbaşı Milas ÜYS YENİ KURUTMA	+ Next page: Previous page:

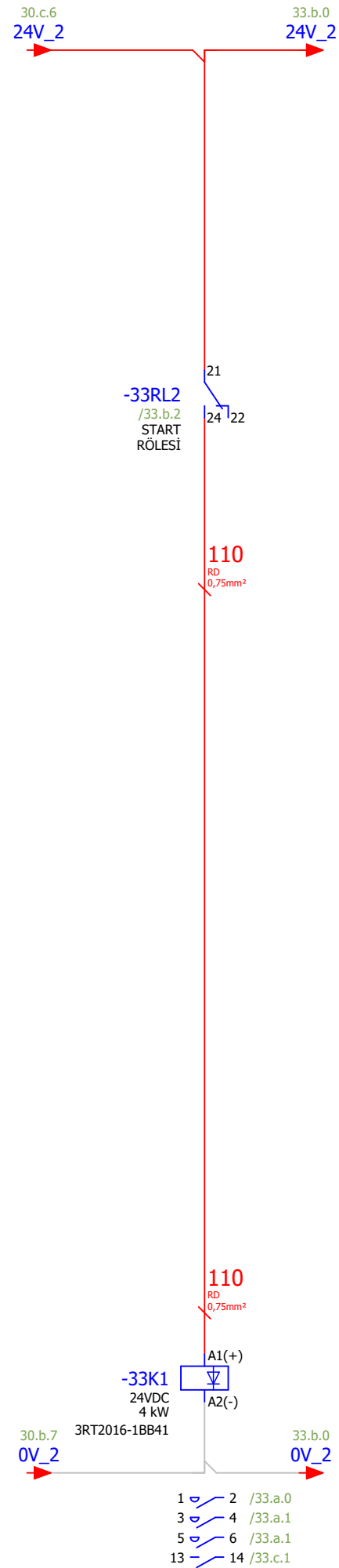
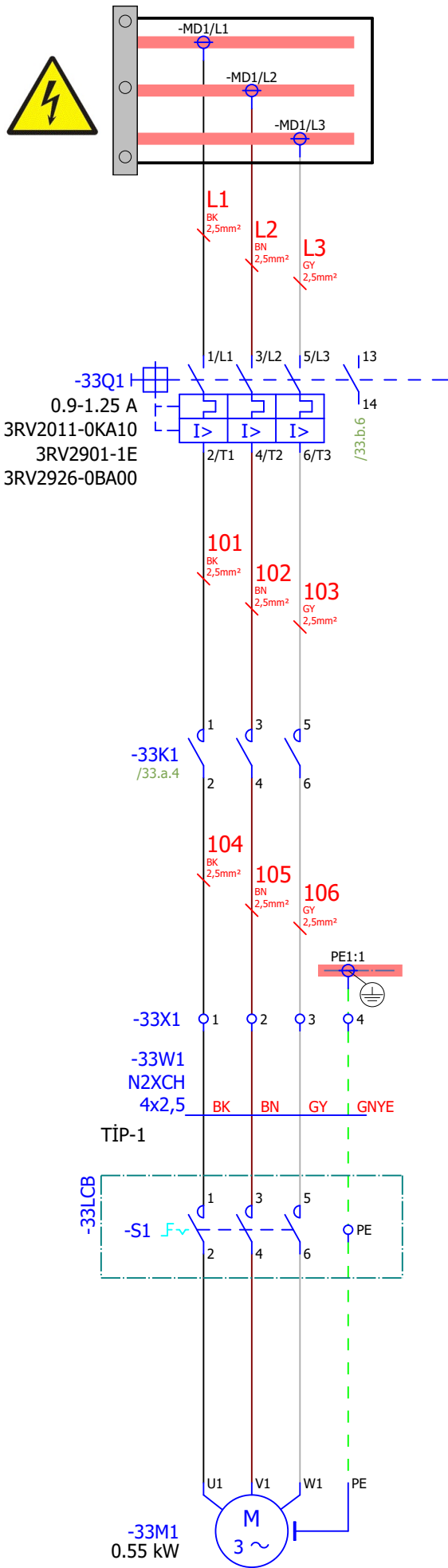

Çizen (Drawing)	Kontrol (Control)	USIA	Kontrol (Control)	esan	Tag Number	Lokasyon	Sayfa açıklaması (Page description)	Proje adı (Project name)	=
Necip SERT Proje Tasarım	Ufuk GÜLÇEN Proje Sorumlusu		Önder KURT Proje Sorumlusu		ESTR-MLS-KUR2-UPS004-xM1-	MCC-2.6	Toz Emiş Boşaltma Up-Sider	Esan Eczacıbaşı Milas ÜYS YENİ KURUTMA	
									+
									MCC
									Next page: 33.b
									Previous page: 32.c

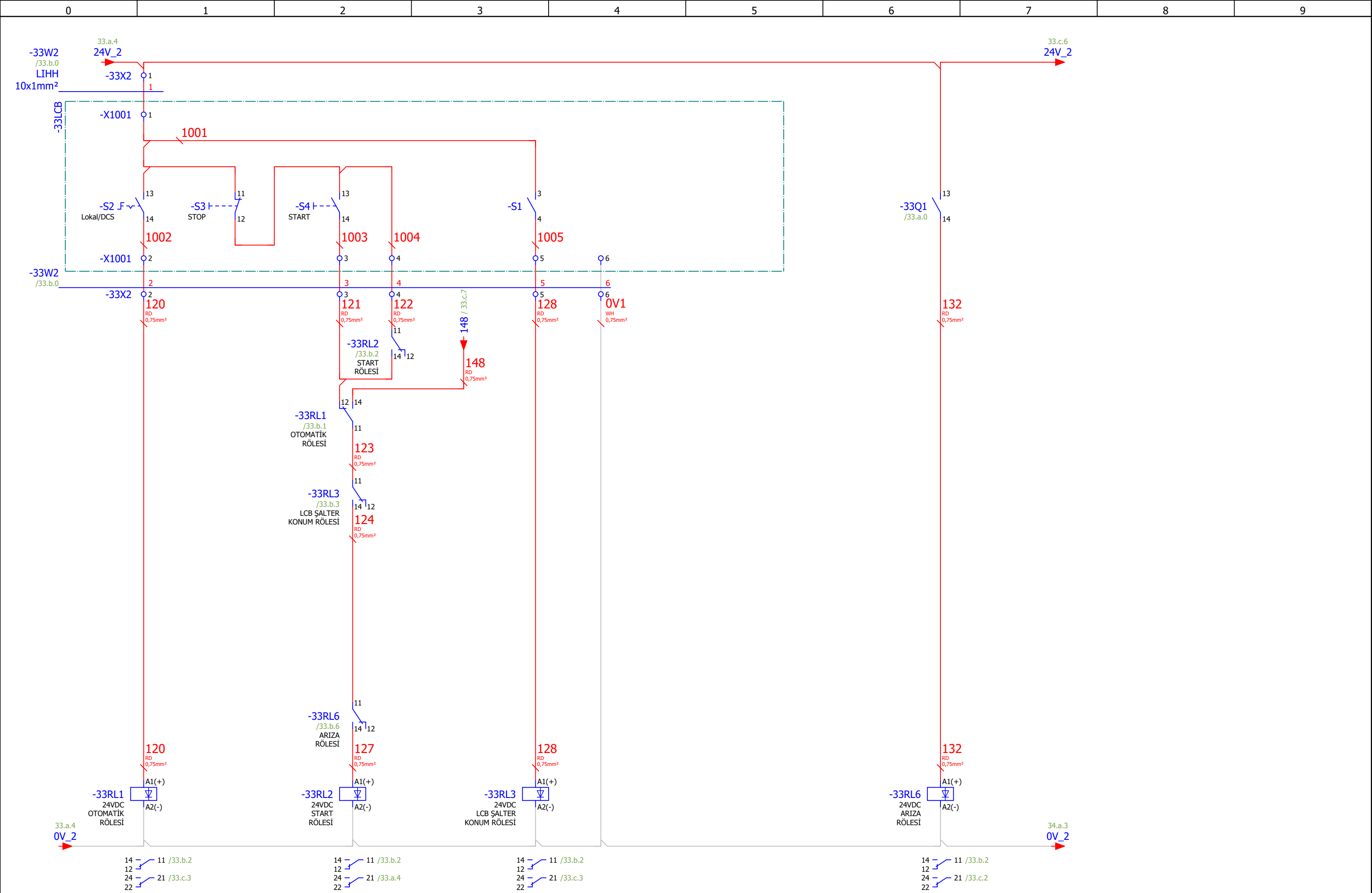

Çizen (Drawing)	Kontrol (Control)	USIA	Kontrol (Control)	Tag Number	Lokasyon	Sayfa açıklaması (Page description)	Proje adı (Project name)
Necip SERT Proje Tasarım	Ufuk GÜLÇEN Proje Sorumlusu		Önder KURT Proje Sorumlusu	ESTR-MLS-KUR2-UPS004-xM1-	MCC-2.6	Toz Emiş Boşaltma Up-Sider	Esan Eczacıbaşı Milas ÜYS YENİ KURUTMA
=							
+							
Next page: 33.c							
Previous page: 33.a							







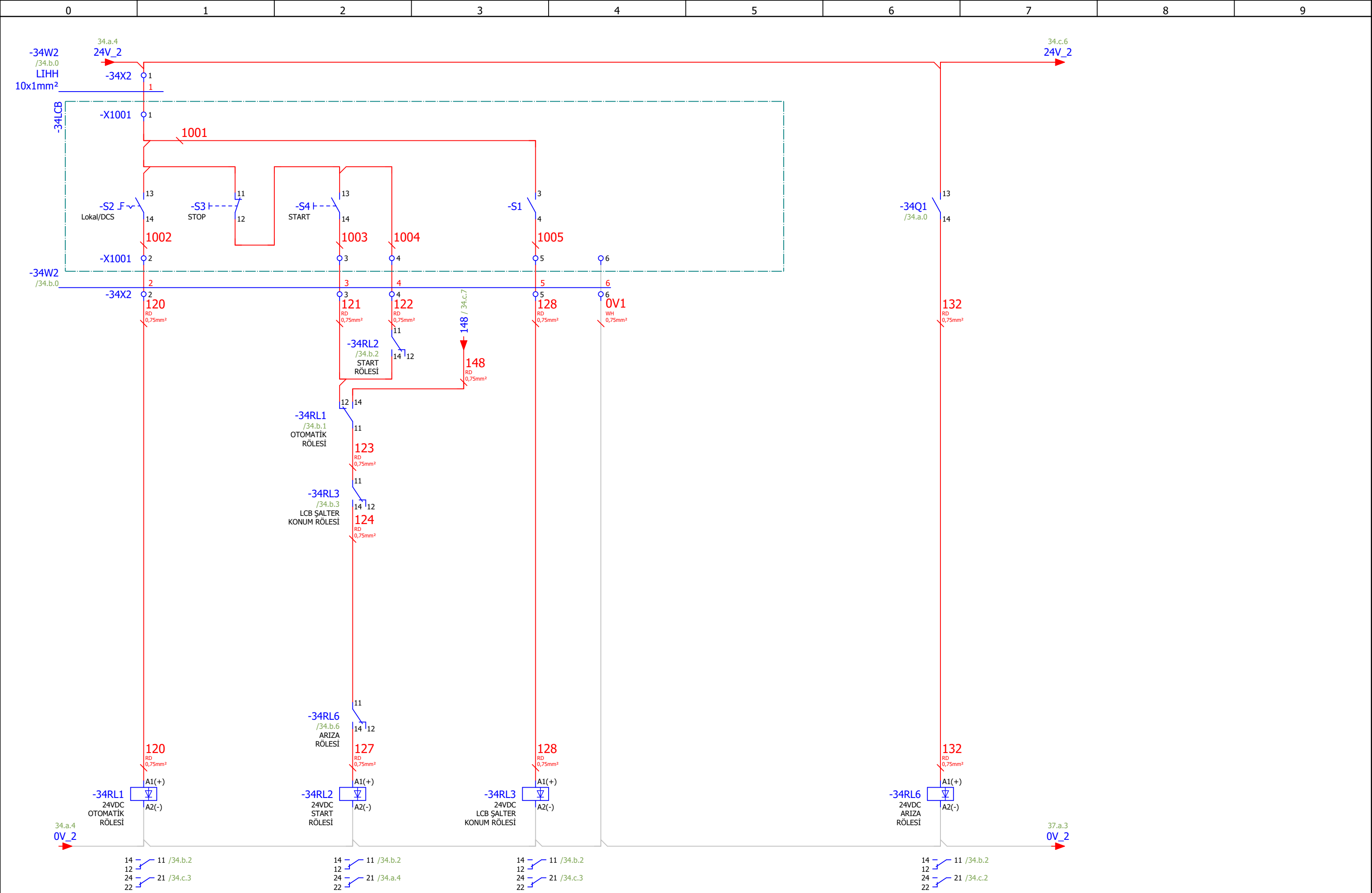

Çizen (Drawing)	Kontrol (Control)	USİA	Kontrol (Control)	Tag Number	Lokasyon	Sayfa açıklaması (Page description)	Proje adı (Project name)
Necip SERT Proje Tasarım	Ufuk GÜLÇEN Proje Sorumlusu		Önder KURT Proje Sorumlusu	ESTR-MLS-KUR2-VIB002-xM1-	MCC-2.7	Kurutucu Toz Toplama Filtre Boşaltma Vidalısı	Esan Eczacıbaşı Milas ÜYS YENİ KURUTMA
=							
+							
Next page: 34.c							
Previous page: 34.a							

**ESTR-MLS-KUR2-VIB002-xM1-**  
Kurutucu Toz Toplama Filtre Boşaltma Vidalsı Çalıştı

**ESTR-MLS-KUR2-VIB002-xM1-**  
Kurutucu Toz Toplama Filtre Boşaltma Vidalsı Arıza

**ESTR-MLS-KUR2-VIB002-xM1-**  
Kurutucu Toz Toplama Filtre Boşaltma Vidalsı Lokal Remote

**ESTR-MLS-KUR2-VIB002-xM1-**  
Kurutucu Toz Toplama Filtre Boşaltma Vidalsı Bakım Şalteri

**ESTR-MLS-KUR2-VIB002-xM1-**  
Kurutucu Toz Toplama Filtre Boşaltma Vidalsı Otomatik Start

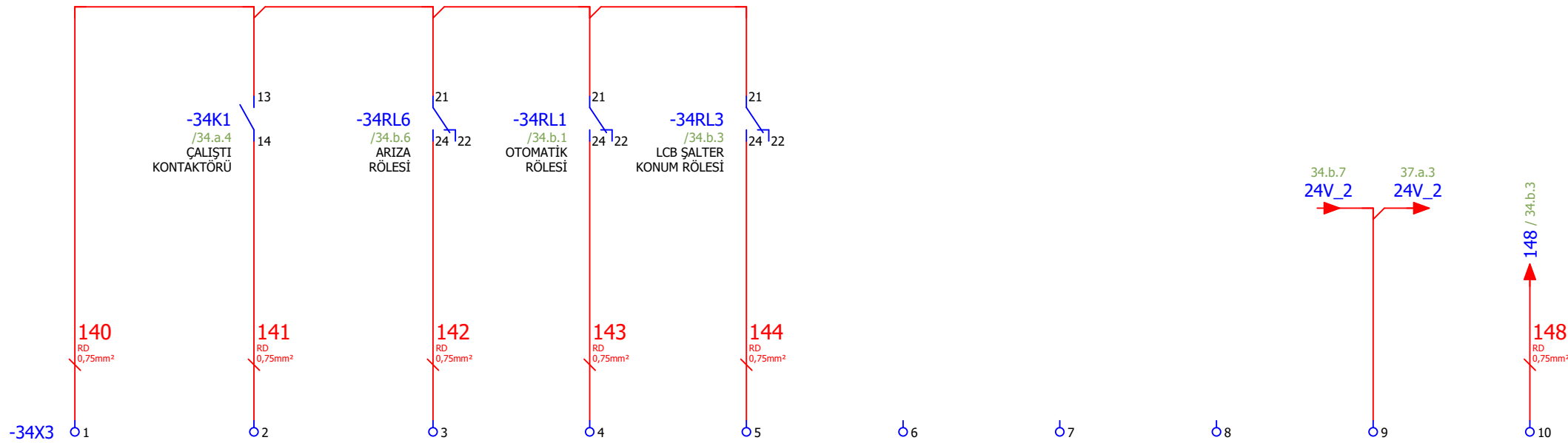

Cizen (Drawing)	Kontrol (Control)	USIA Unique Software at Applications an EPC company	Kontrol (Control)	esan	Tag Number	Lokasyon	Sayfa açıklaması (Page description)	Proje adı (Project name)	=
Necip SERT Proje Tasarım	Ufuk GÜLÇEN Proje Sorumlusu		Önder KURT Proje Sorumlusu		ESTR-MLS-KUR2-VIB002-xM1-	MCC-2.7	Kurutucu Toz Toplama Filtre Boşaltma Vidalsı	Esan Eczacıbaşı Milas ÜYS YENİ KURUTMA	+ MCC

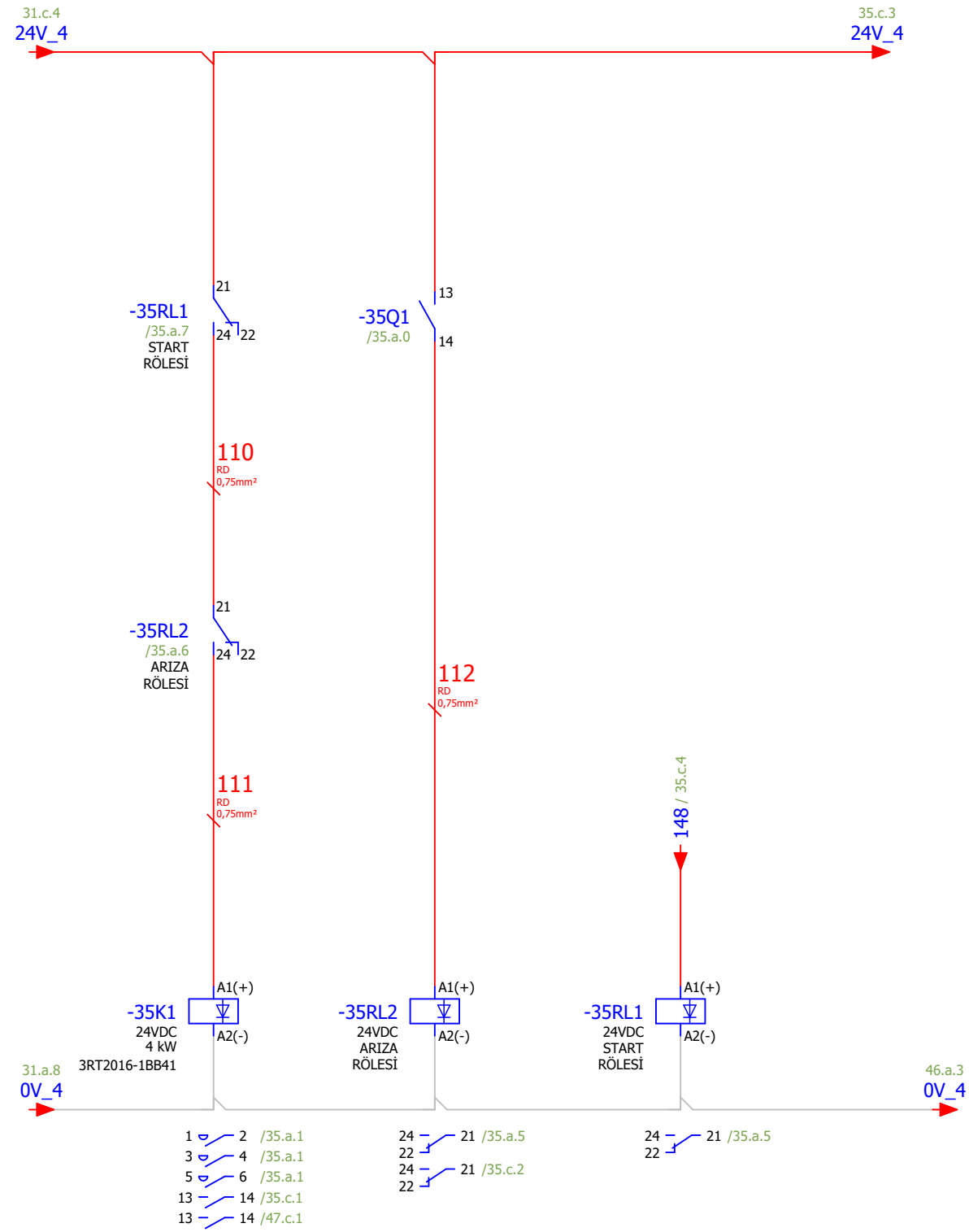
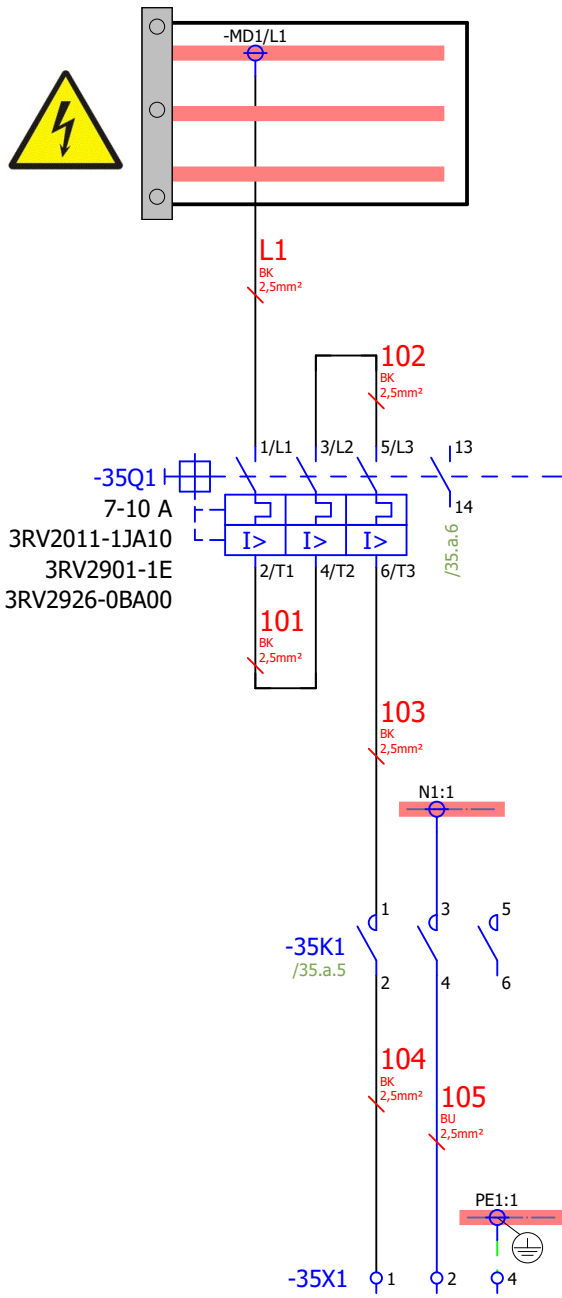

Çizen (Drawing)	Kontrol (Control)
Necip SERT Proje Tasarım	Ufuk GÜLÇEN Proje Sorumlusu

Kontrol (Control)	Önder KURT Proje Sorumlusu
-------------------	-------------------------------



Tag Number	ESTR-MLS-DRY2-FIL002-xM2-
------------	---------------------------

Lokasyon	MCC-4.8
----------	---------

Sayfa açıklaması (Page description)	Filtre 3 - Silo Hatları Toz Toplama Patlaç
-------------------------------------	--

Proje adı (Project name)	Esan Eczacıbaşı Milas ÜYS YENİ KURUTMA
--------------------------	--

=	MCC
+	35.c
Next page:	34.c
Previous page:	34.c



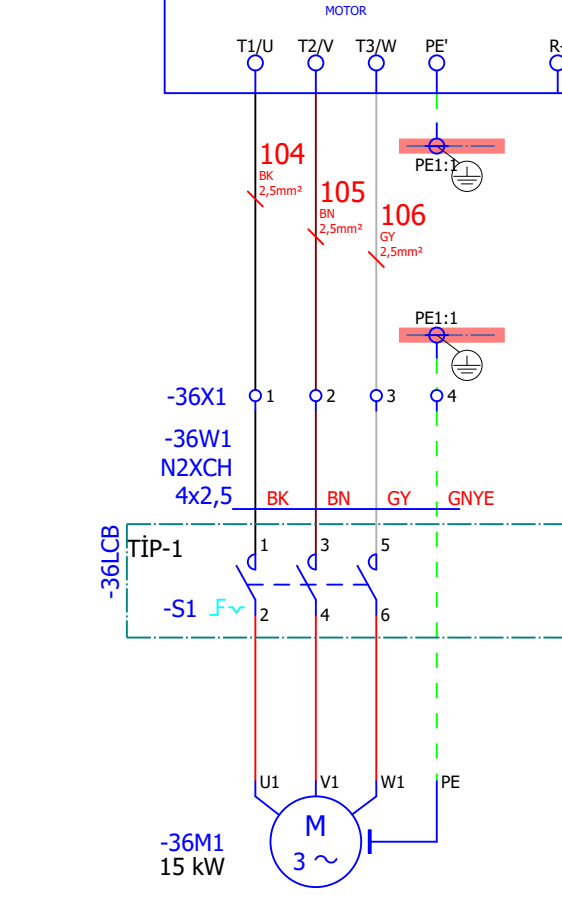
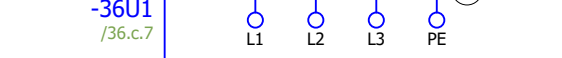
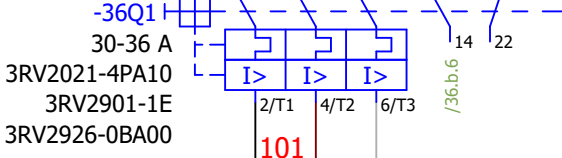
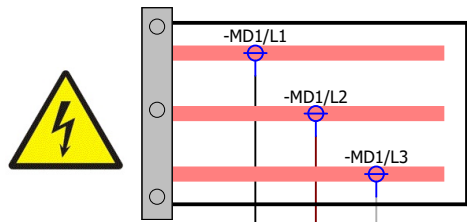

36.a.3 / 24V\_12 → 24V\_12 / 36.a.2  
36.a.3 / 0V\_12 → 0V\_12 / 36.a.2

**!!! DİKKAT !!!**  
MOTOR YOL VERİCİ KORUMA ŞALTERİ  
HIZ KONTROL (VFD) GÜCÜNE GÖRE SEÇİLMİŞTİR .  
MOTOR KORUMA FONKSİYONU  
HIZ KONTROL (VFD) TARAFINDAN YAPILMAKTADIR .



ABB - ACS880 R3



İP	İP
SUBNET	SUBNET
GATEWAY	GATEWAY

**NOT:**  
Sürücü Hata Bilgisi,  
Sürücüde " NC " olarak Ayarlanmıştır...

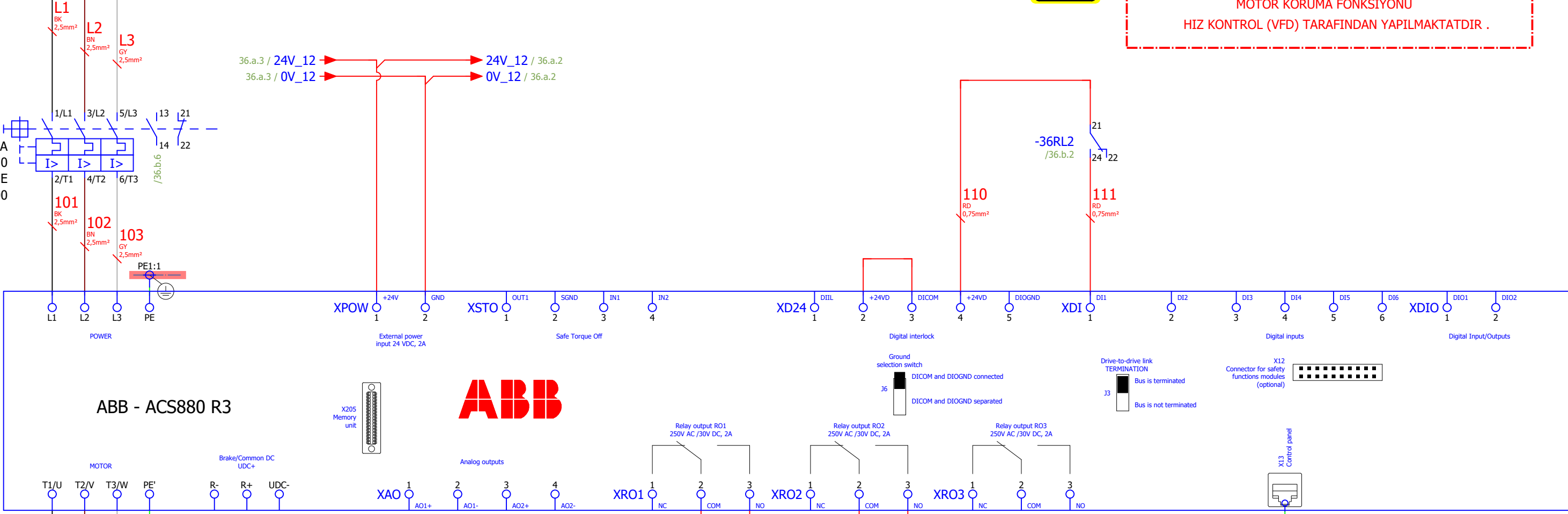
Cizen (Drawing)	Kontrol (Control)
Necip SERT Proje Tasarım	Ufuk GÜLÇEN Proje Sorumlusu



Kontrol (Control)
Önder KURT Proje Sorumlusu



Tag Number
ESTR-MLS-DRY2-FIL002-xM1-

Lokasyon
MCC-12.1

Sayfa açıklaması (Page description)
Filtre 3 - Silo Hatları Toz Toplama Fanı

Proje adı (Project name)
Esan Eczacıbaşı Milas ÜYS YENİ KURUTMA

=
+ MCC
Next page: 36.b
Previous page: 35.c

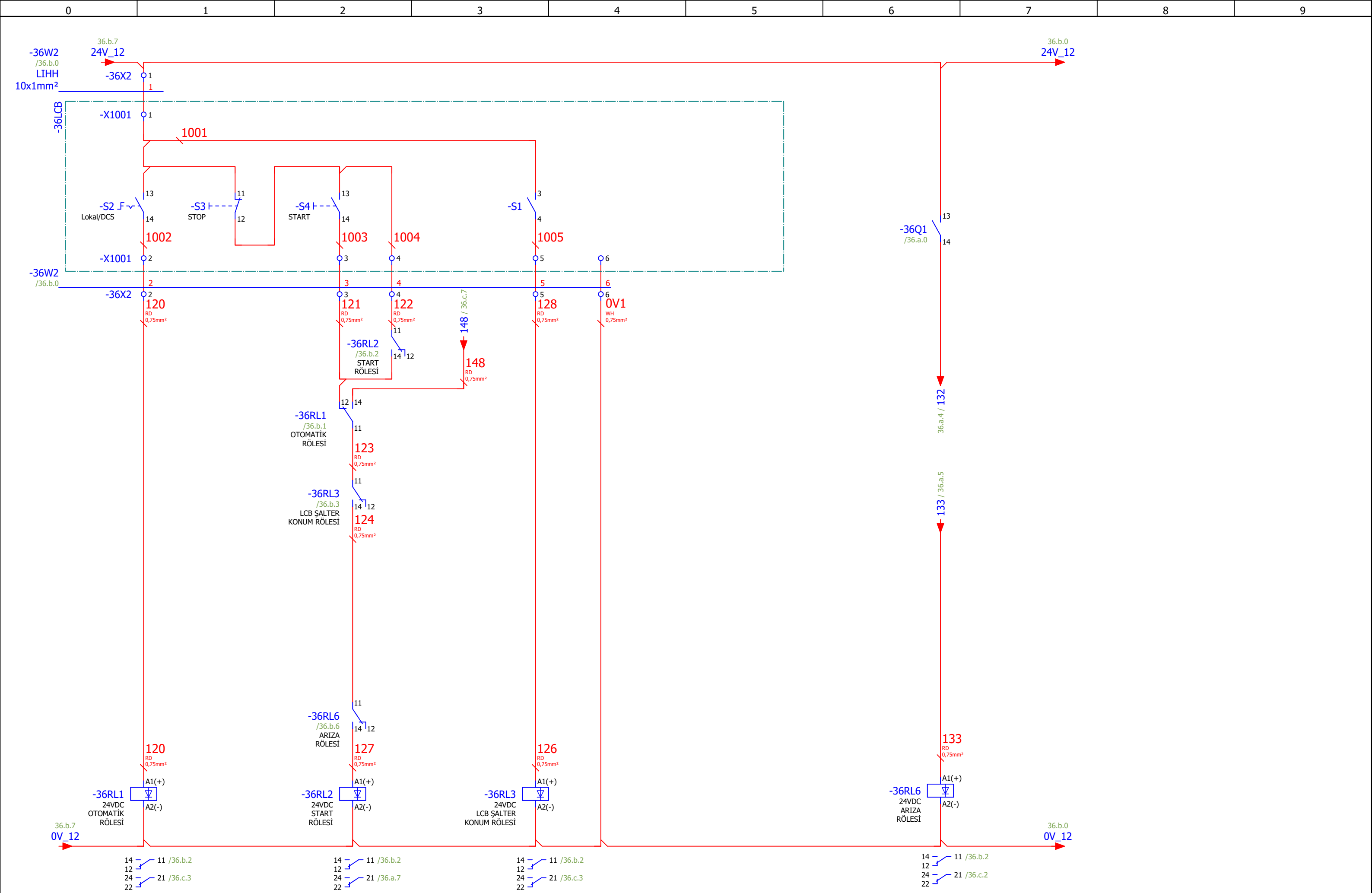

36.a

Page: 36.b

Çizen (Drawing)	Kontrol (Control)	USIA	Kontrol (Control)	Tag Number	Lokasyon	Sayfa açıklaması (Page description)	Proje adı (Project name)
Necip SERT Proje Tasarım	Ufuk GÜLÇEN Proje Sorumlusu		Önder KURT Proje Sorumlusu	ESTR-MLS-DRY2-FIL002-xM1-	MCC-12.1	Filtre 3 - Silo Hatları Toz Toplama Fanı	Esan Eczacıbaşı Milas ÜYİ YENİ KURUTMA
=							
+							
Next page: 36.c							
Previous page: 36.a							





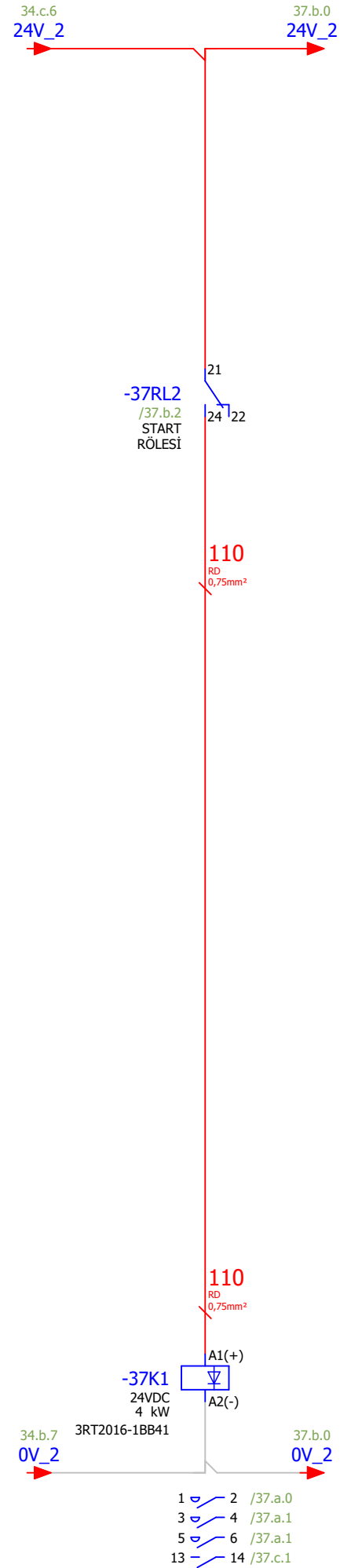
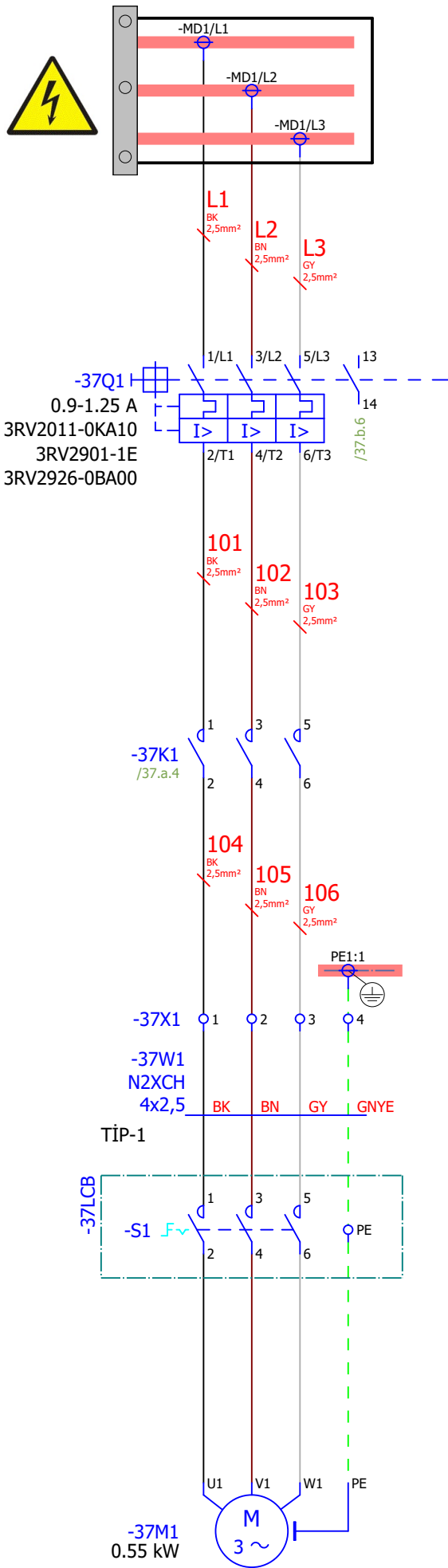

Çizen (Drawing)	Kontrol (Control)
Necip SERT Proje Tasarım	Ufuk GÜLÇEN Proje Sorumlusu

	Kontrol (Control)
	Önder KURT Proje Sorumlusu



Tag Number
ESTR-MLS-KUR2-UPS001-xM1-

Lokasyon
<b>MCC-2.8</b>

Sayfa açıklaması (Page description)
Silo Hatları Toz Toplama Up-sider

Proje adı (Project name)
Esan Eczacıbaşı Milas ÜYS YENİ KURUTMA

=	
+	MCC
Next page:	37.b
Previous page:	36.c

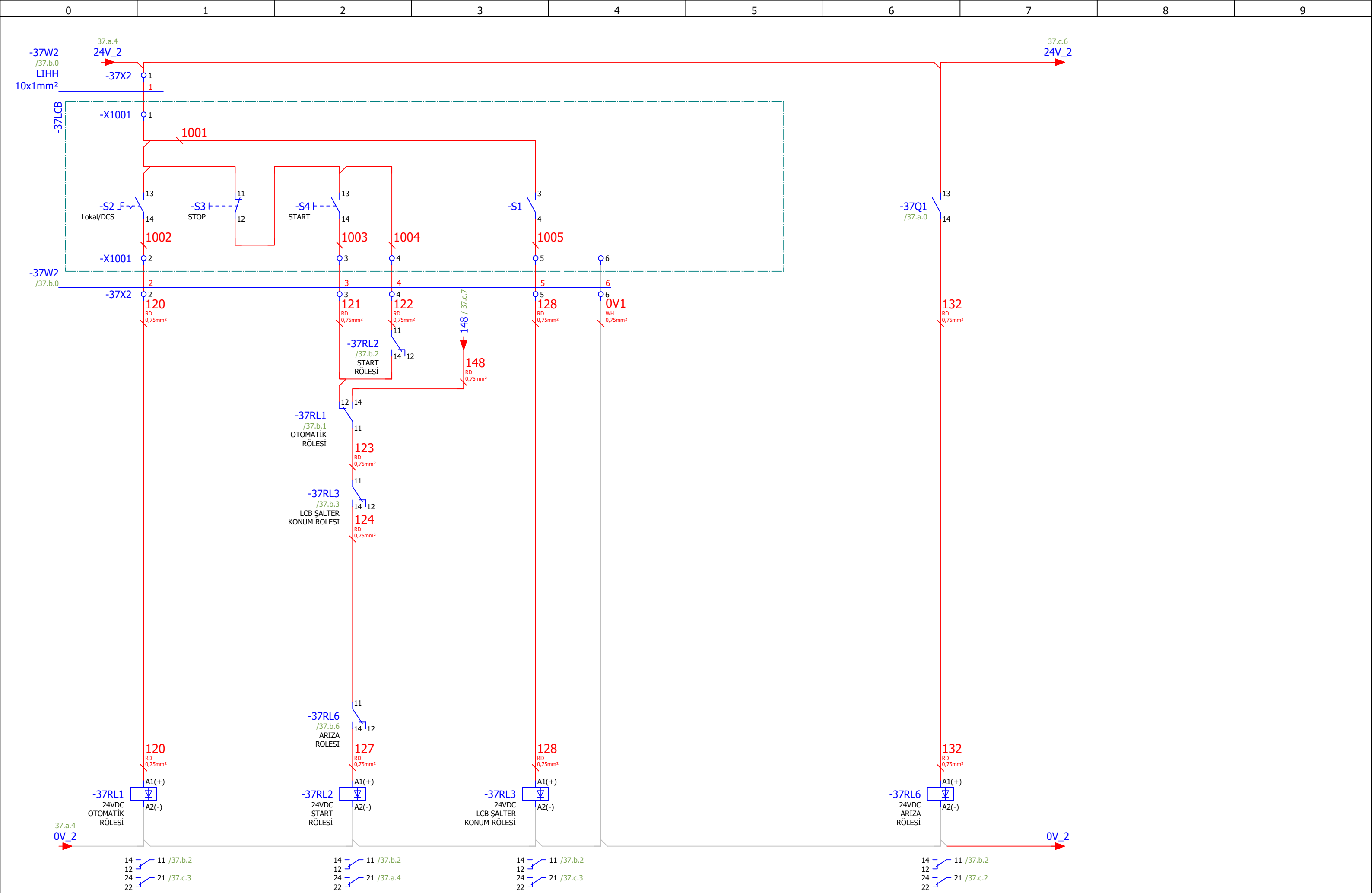

Çizen (Drawing)	Kontrol (Control)	US	Kontrol (Control)	Tag Number	Lokasyon	Sayfa açıklaması (Page description)	Proje adı (Project name)	=
Necip SERT Proje Tasarım	Ufuk GÜLÇEN Proje Sorumlusu		Önder KURT Proje Sorumlusu	ESTR-MLS-KUR2-UPS001-xM1-	MCC-2.8	Silo Hatları Toz Toplama Up-sider	Esan Eczacıbaşı Milas ÜYS YENİ KURUTMA	+
								MCC
								Next page: 37.c
								Previous page: 37.a





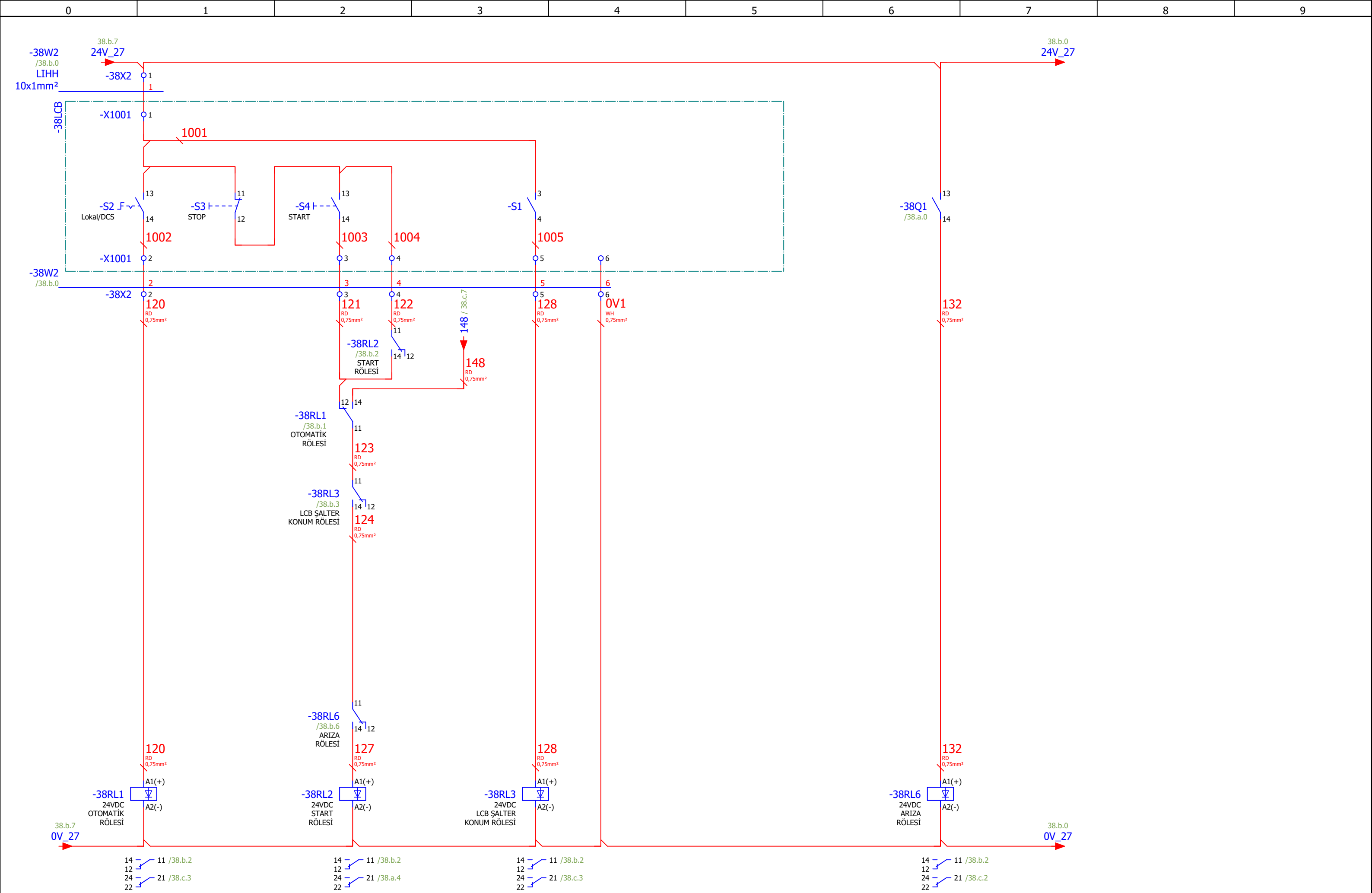

38.a

Page: 38.b

Çizen (Drawing)	Kontrol (Control)	USIA	Kontrol (Control)	Tag Number	Lokasyon	Sayfa açıklaması (Page description)	Proje adı (Project name)
Necip SERT Proje Tasarım	Ufuk GÜLÇEN Proje Sorumlusu		Önder KURT Proje Sorumlusu	ESTR-MLS-DRY2-VIB004-xM1	MCC-27.1	Toz Toplama/ Boşaltma Vidalısı	Esan Eczacıbaşı Milas ÜYS YENİ KURUTMA
=							
+							
Next page: 38.c							
Previous page: 38.a							

ESTR-MLS-DRY2-VIB004-xM1  
Toz Toplama/ Boşaltma Vidalısı  
Çalıştı

ESTR-MLS-DRY2-VIB004-xM1  
Toz Toplama/ Boşaltma Vidalısı  
Arıza

ESTR-MLS-DRY2-VIB004-xM1  
Toz Toplama/ Boşaltma Vidalısı  
Lokal Remote

ESTR-MLS-DRY2-VIB004-xM1  
Toz Toplama/ Boşaltma Vidalısı  
Bakım Şalteri

ESTR-MLS-DRY2-VIB004-xM1  
Toz Toplama/ Boşaltma Vidalısı  
Otomatik Start

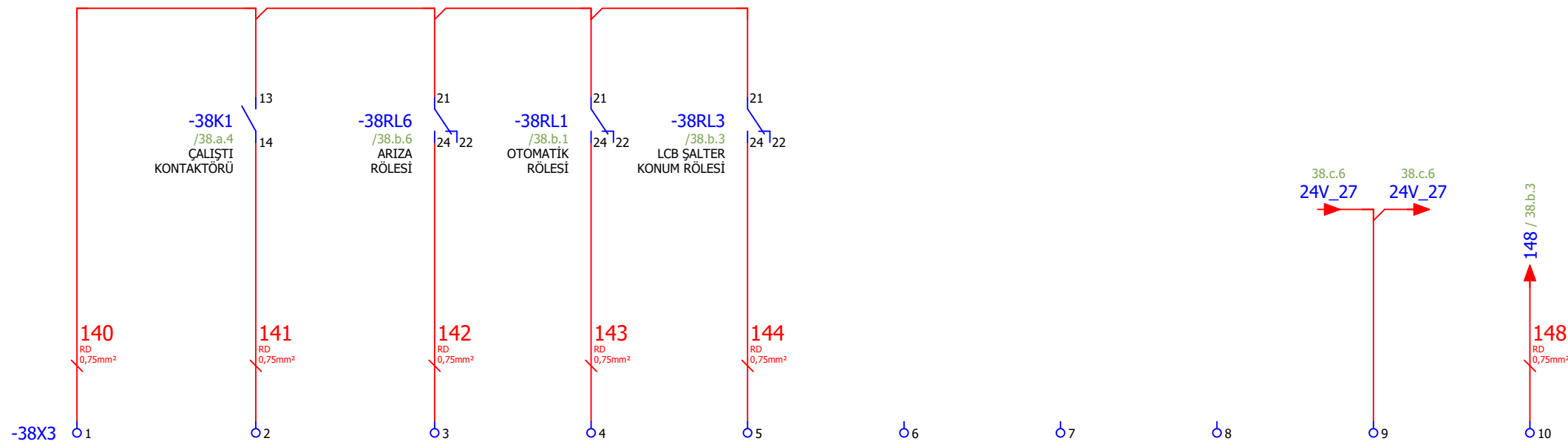

Cizen (Drawing)	Kontrol (Control)	USIA Unique Software at Applications an EPC company	Kontrol (Control)	esan	Tag Number	Lokasyon	Sayfa açıklaması (Page description)	Proje adı (Project name)	=
Necip SERT Proje Tasarım	Ufuk GÜLÇEN Proje Sorumlusu		Önder KURT Proje Sorumlusu		ESTR-MLS-DRY2-VIB004-xM1	MCC-27.1	Toz Toplama/ Boşaltma Vidalısı	Esan Eczacıbaşı Milas ÜYS YENİ KURUTMA	
									+ MCC
									Next page: 39.a
									Previous page: 38.b

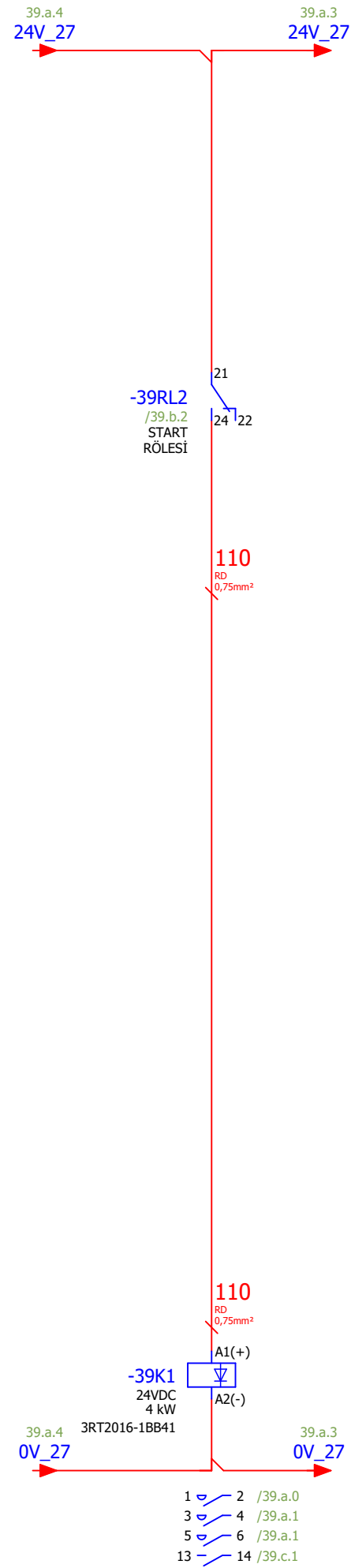
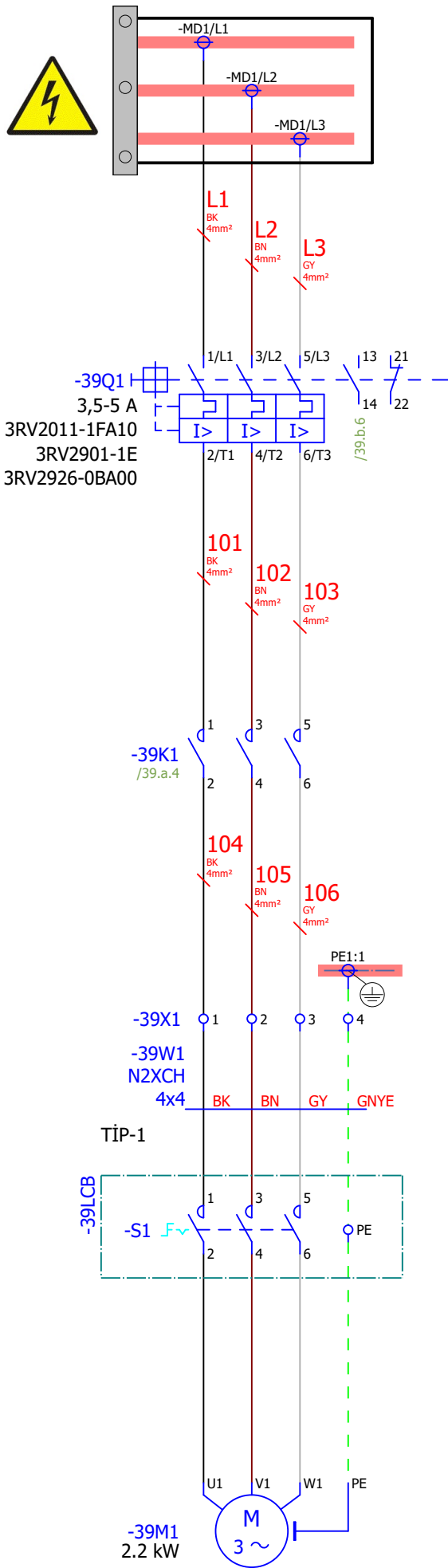

Çizen (Drawing)	Kontrol (Control)
Necip SERT Proje Tasarım	Ufuk GÜLÇEN Proje Sorumlusu

	Kontrol (Control)
	Önder KURT Proje Sorumlusu



Tag Number
ESTR-MLS-DRY2-CNV002-xM1-

Lokasyon
<b>MCC-27.2</b>

Sayfa açıklaması (Page description)
Döner Fırın Boşaltma Bandı

Proje adı (Project name)
Esan Eczacıbaşı Milas ÜYS YENİ KURUTMA

=	
+	MCC
Next page:	39.b
Previous page:	38.c



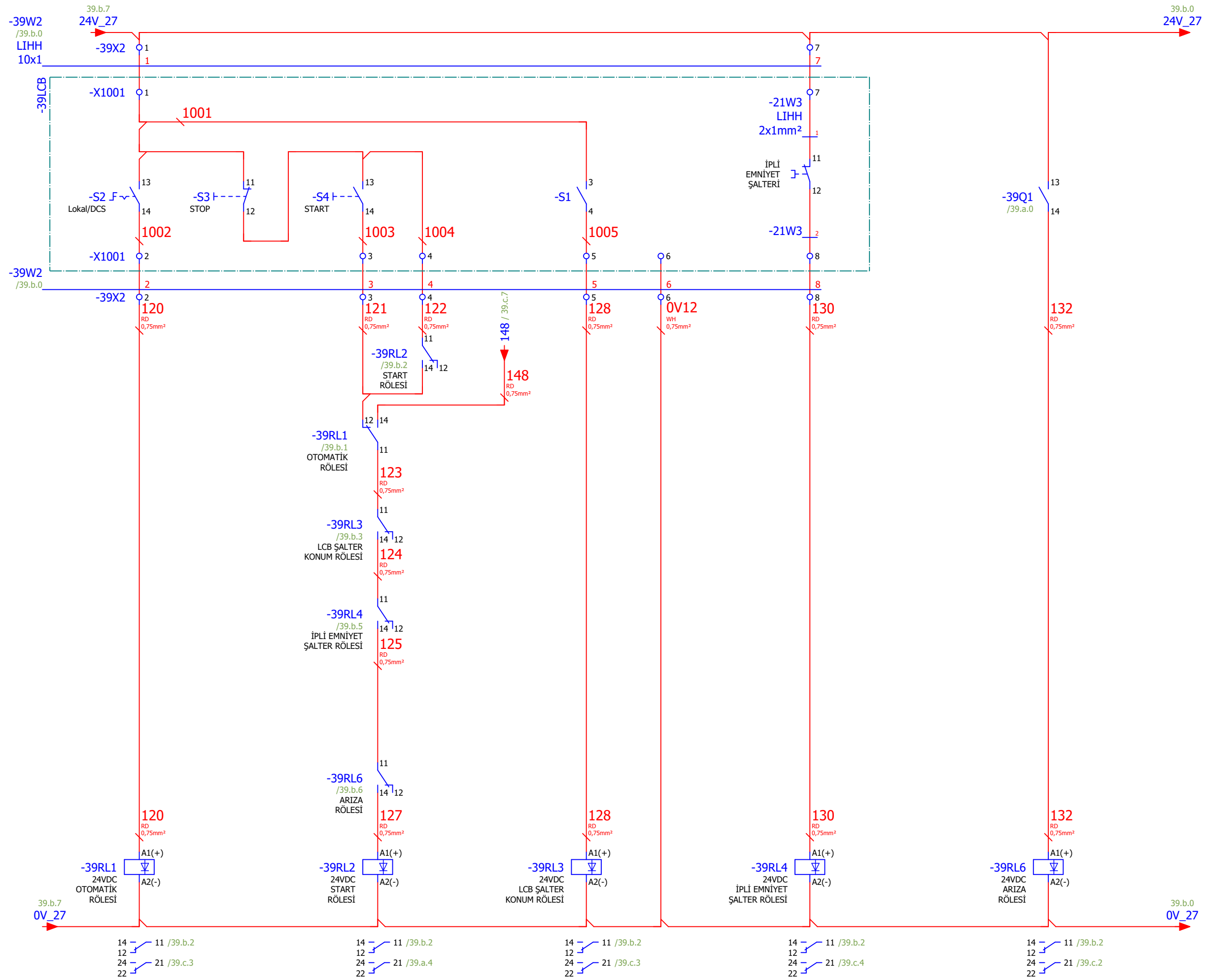

Çizen (Drawing)	Kontrol (Control)	USIA Unique Software at Applications an EPC company	Kontrol (Control)	Tag Number	Lokasyon	Sayfa açıklaması (Page description)	Proje adı (Project name)	=
Necip SERT Proje Tasarım	Ufuk GÜLÇEN Proje Sorumlusu		Önder KURT Proje Sorumlusu	ESTR-MLS-DRY2-CNV002-xM1-	MCC-27.2	Döner Fırın Boşaltma Bandı	Esan Eczacıbaşı Milas ÜYS YENİ KURUTMA	MCC
								Next page: 39.c
								Previous page: 39.a



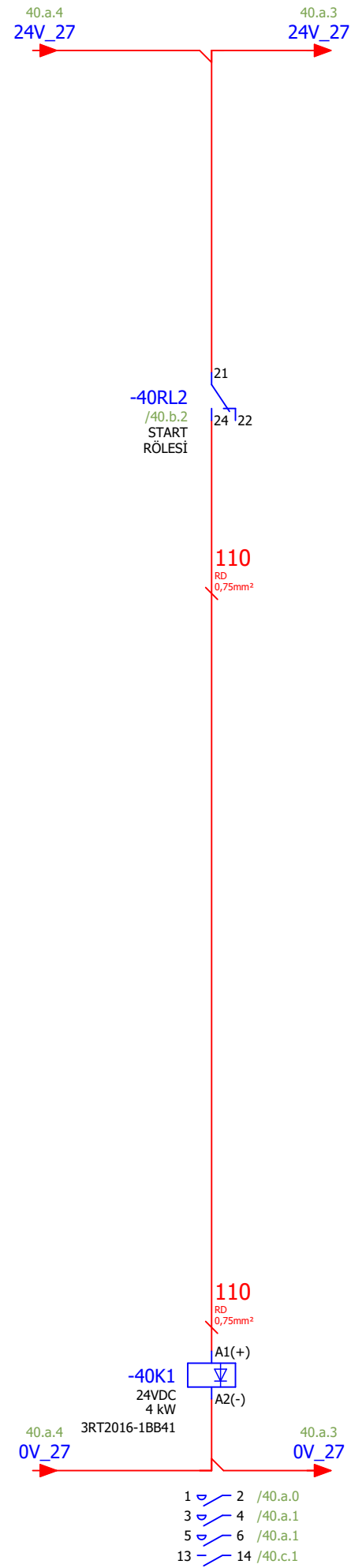
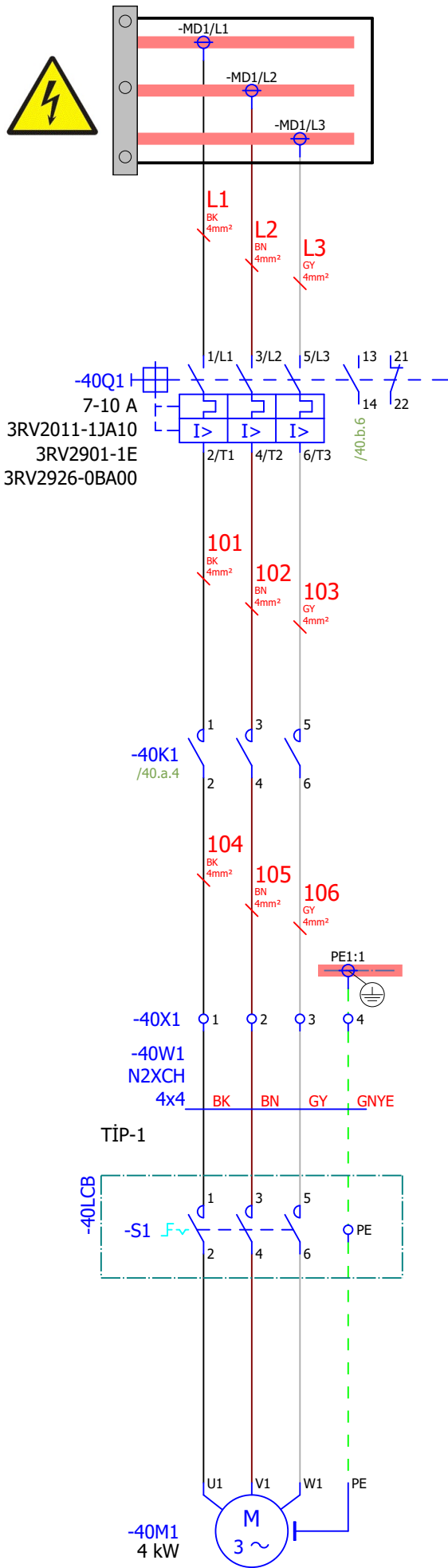

Çizen (Drawing)	Kontrol (Control)	USIA	Kontrol (Control)	esan	Tag Number	Lokasyon	Sayfa açıklaması (Page description)	Proje adı (Project name)	=
Necip SERT Proje Tasarım	Ufuk GÜLÇEN Proje Sorumlusu		Önder KURT Proje Sorumlusu		ESTR-MLS-KUR2-CNV003-xM1-	MCC-27.3	Kısa Bant	Esan Eczacıbaşı Milas ÜYS YENİ KURUTMA	
									MCC
									Next page: 40.b
									Previous page: 39.c

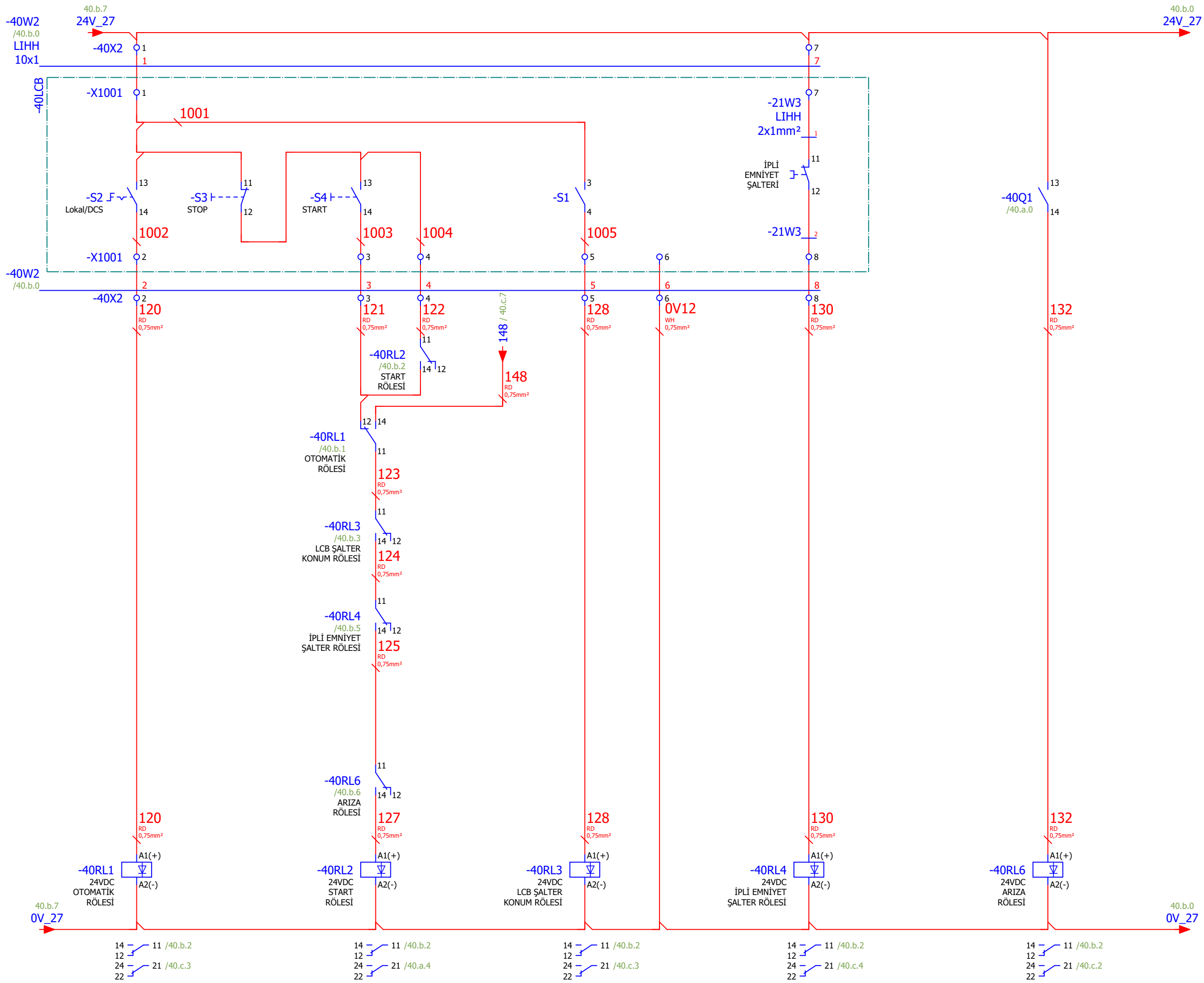

40.a

Page: 40.b

Çizen (Drawing)	Kontrol (Control)	USIA	Kontrol (Control)	Tag Number	Lokasyon	Sayfa açıklaması (Page description)	Proje adı (Project name)	=
Necip SERT Proje Tasarım	Ufuk GÜLÇEN Proje Sorumlusu		Önder KURT Proje Sorumlusu	ESTR-MLS-KUR2-CNV003-xM1-	MCC-27.3	Kısa Bant	Esan Eczacıbaşı Milas ÜYS YENİ KURUTMA	MCC
								Next page: 40.c
								Previous page: 40.a



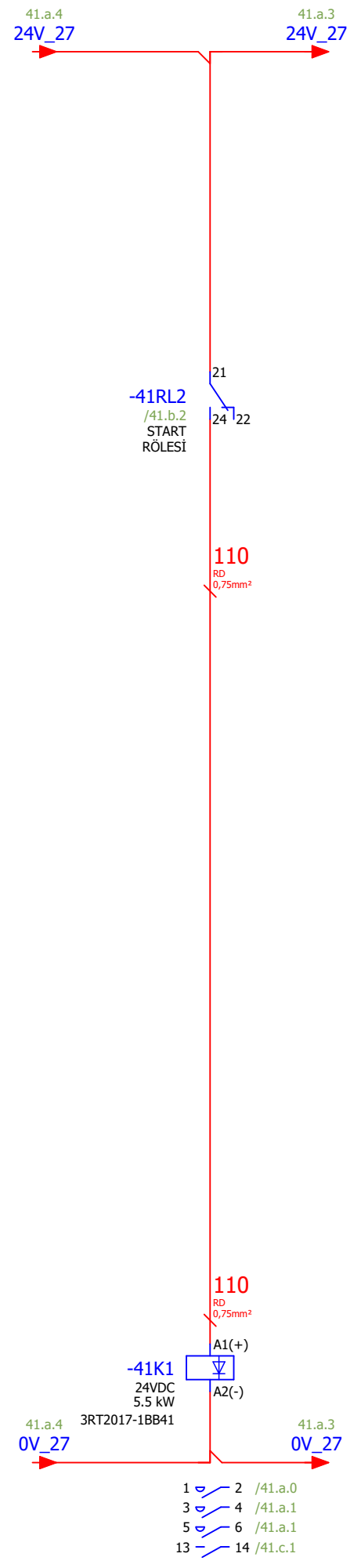
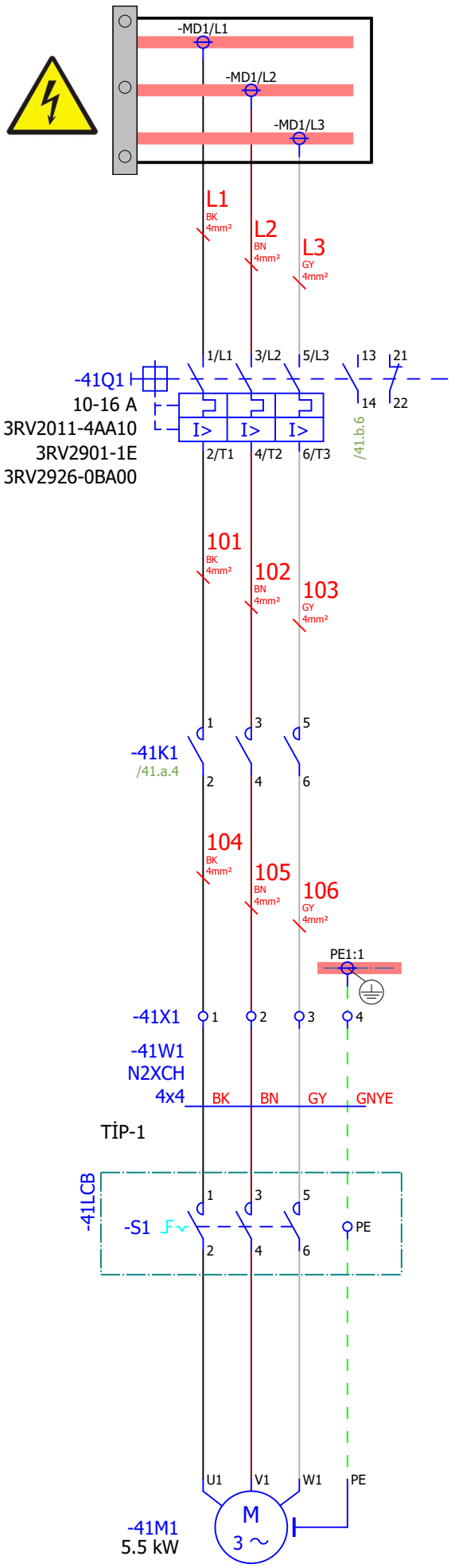

40.c

Page: 41.a

Çizen (Drawing)	Kontrol (Control)	USIA	Kontrol (Control)	esan	Tag Number	Lokasyon	Sayfa açıklaması (Page description)	Proje adı (Project name)	=
Necip SERT Proje Tasarım	Ufuk GÜLÇEN Proje Sorumlusu		Önder KURT Proje Sorumlusu		ESTR-MLS-KUR2-CNV004-xM1-	MCC-27.4	Uzun Bant	Esan Eczacıbaşı Milas ÜYS YENİ KURUTMA	MCC
									Next page: 41.b
									Previous page: 40.c

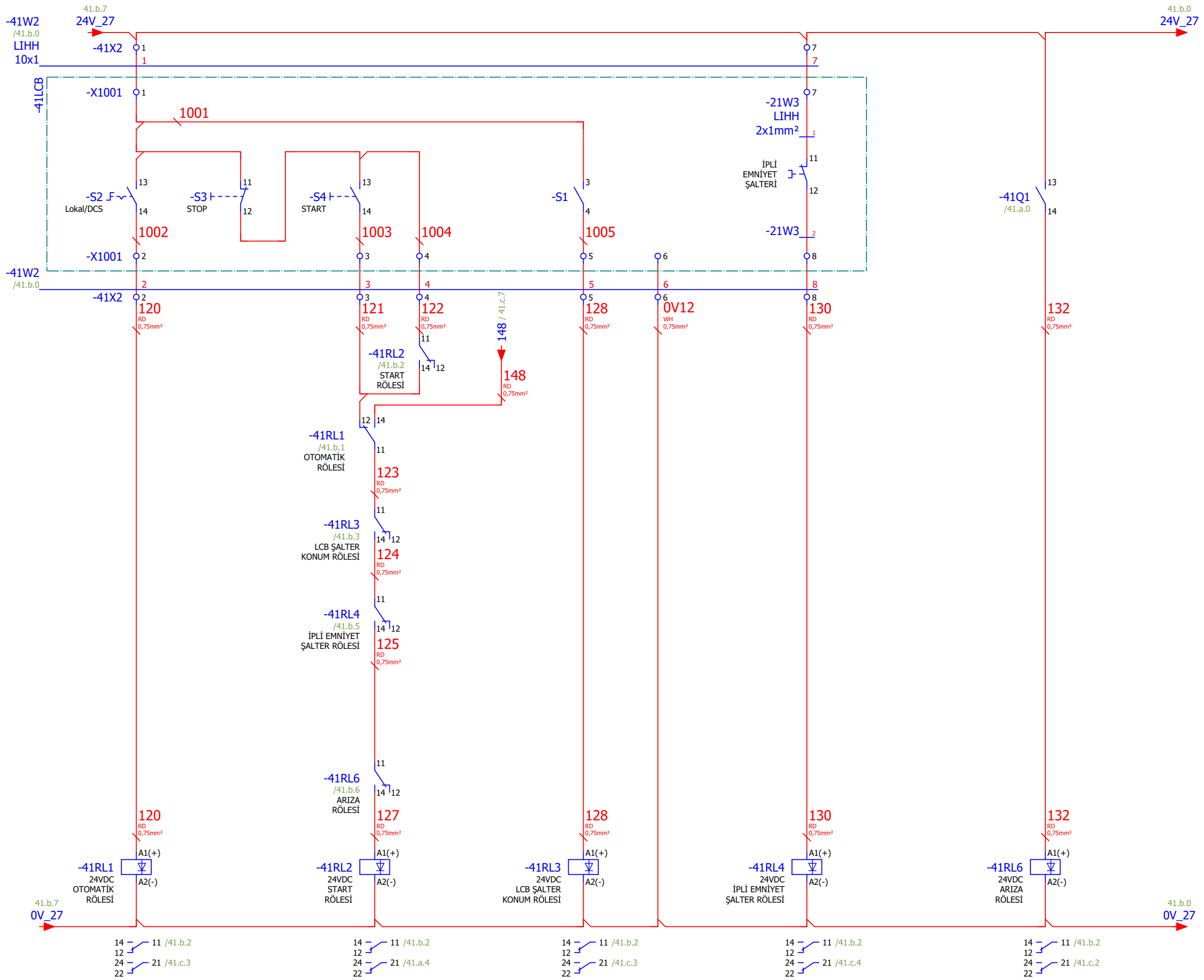

41.a

Page: 41.b

Çizen (Drawing)	Kontrol (Control)	USIA	Kontrol (Control)	Tag Number	Lokasyon	Sayfa açıklaması (Page description)	Proje adı (Project name)
Necip SERT Proje Tasarım	Ufuk GÜLÇEN Proje Sorumlusu		Önder KURT Proje Sorumlusu	ESTR-MLS-KUR2-CNV004-xM1-	MCC-27.4	Uzun Bant	Esan Eczacıbaşı Milas ÜYS YENİ KURUTMA
=							
+							
Next page: 41.c							
Previous page: 41.a							

ESTR-MLS-KUR2-CNV004-xM1-  
Uzun Bant  
Çalıştı

ESTR-MLS-KUR2-CNV004-xM1-  
Uzun Bant  
Arıza

ESTR-MLS-KUR2-CNV004-xM1-  
Uzun Bant  
Lokal Remote

ESTR-MLS-KUR2-CNV004-xM1-  
Uzun Bant  
Bakım Şalteri

ESTR-MLS-KUR2-CNV004-xM1-  
Uzun Bant  
İpli Emniyet Şalteri

ESTR-MLS-KUR2-CNV004-xM1-  
Uzun Bant  
Otomatik Start

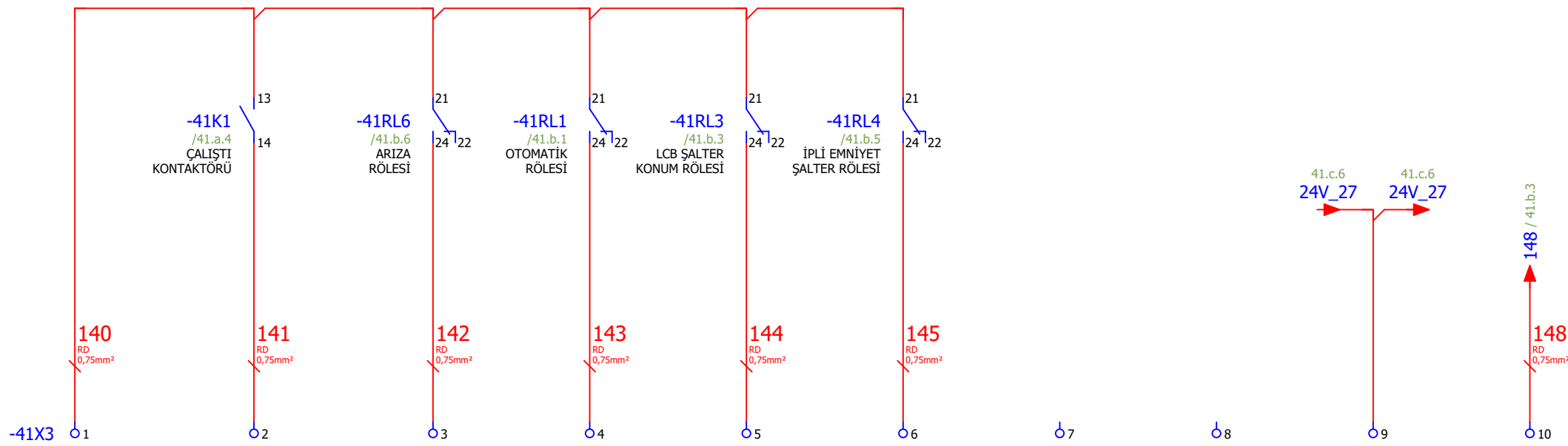

Çizen (Drawing)	Kontrol (Control)	USIA Unique Software at Applications an EPC company	Kontrol (Control)	esan	Tag Number	Lokasyon	Sayfa açıklaması (Page description)	Proje adı (Project name)	=
Necip SERT Proje Tasarım	Ufuk GÜLÇEN Proje Sorumlusu		Önder KURT Proje Sorumlusu		ESTR-MLS-KUR2-CNV004-xM1-	MCC-27.4	Uzun Bant	Esan Eczacıbaşı Milas ÜYS YENİ KURUTMA	+ MCC
									Next page: 42.a
									Previous page: 41.b



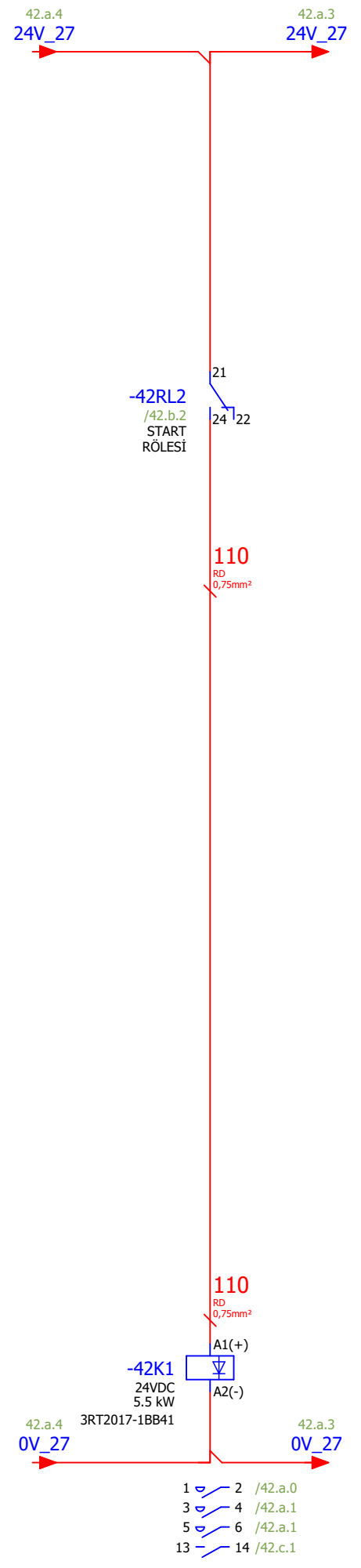
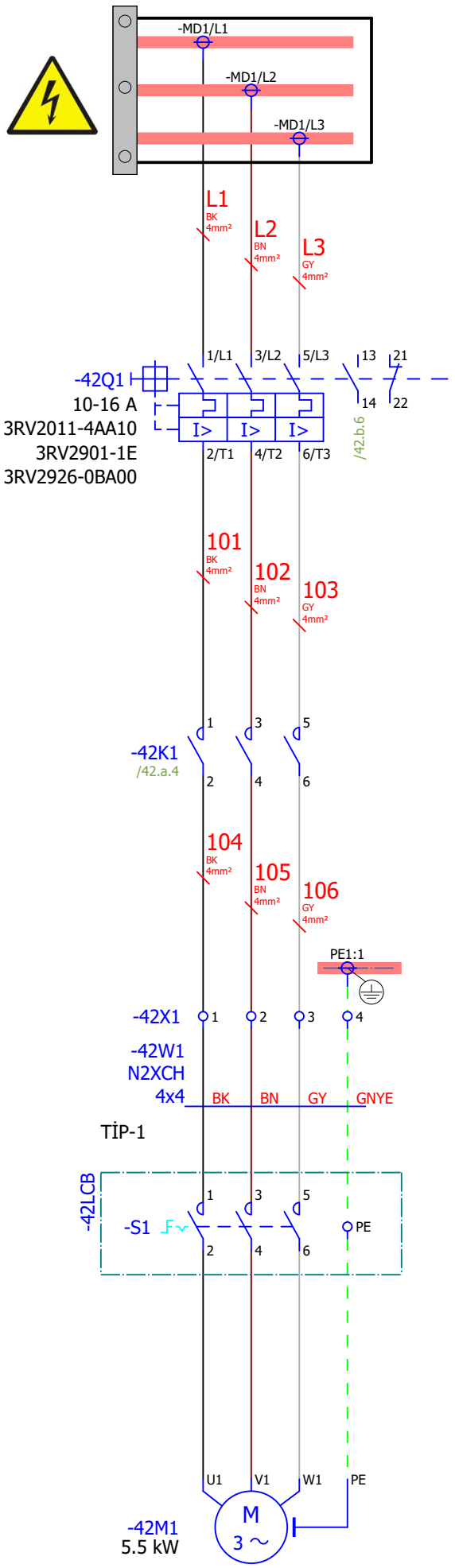

41.c

Page: 42.a

Cizen (Drawing)	Kontrol (Control)	USIA	Kontrol (Control)	esan	Tag Number	Lokasyon	Sayfa açıklaması (Page description)	Proje adı (Project name)	=
Necip SERT Proje Tasarım	Ufuk GÜLÇEN Proje Sorumlusu		Önder KURT Proje Sorumlusu		ESTR-MLS-KUR2-CNV005-xM1-	MCC-27.5	Eski Öğütme Besleme Bandı	Esan Eczacıbaşı Milas ÜYS YENİ KURUTMA	
									MCC
									Next page: 42.b
									Previous page: 41.c

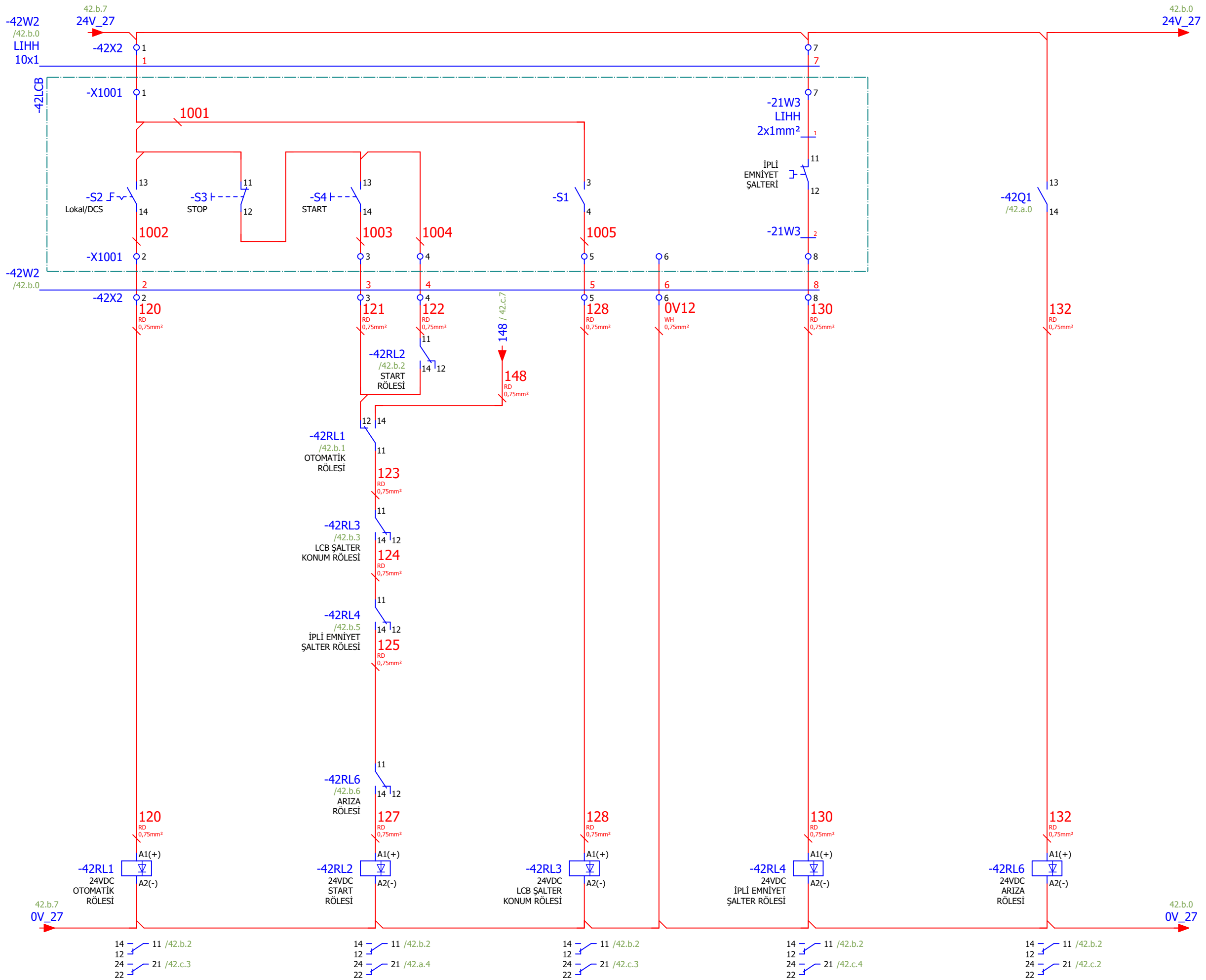

Çizen (Drawing)	Kontrol (Control)	USIA Unique Software Applications an EPC company	Kontrol (Control)	esan	Tag Number	Lokasyon	Sayfa açıklaması (Page description)	Proje adı (Project name)	=
Necip SERT Proje Tasarım	Ufuk GÜLÇEN Proje Sorumlusu		Önder KURT Proje Sorumlusu		ESTR-MLS-KUR2-CNV005-xM1-	MCC-27.5	Eski Öğütme Besleme Bandı	Esan Eczacıbaşı Milas ÜYS YENİ KURUTMA	
									+ MCC
									Next page: 42.c
									Previous page: 42.a



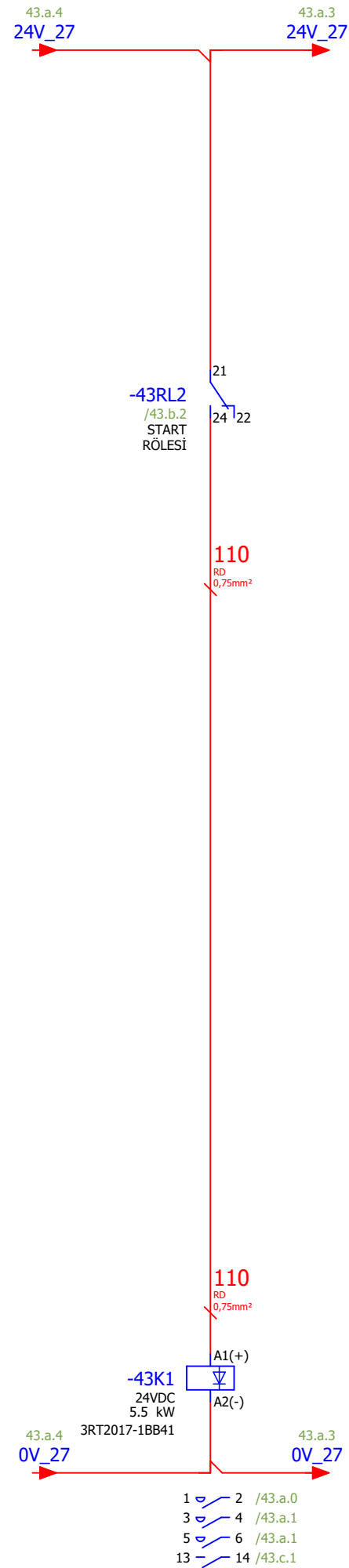
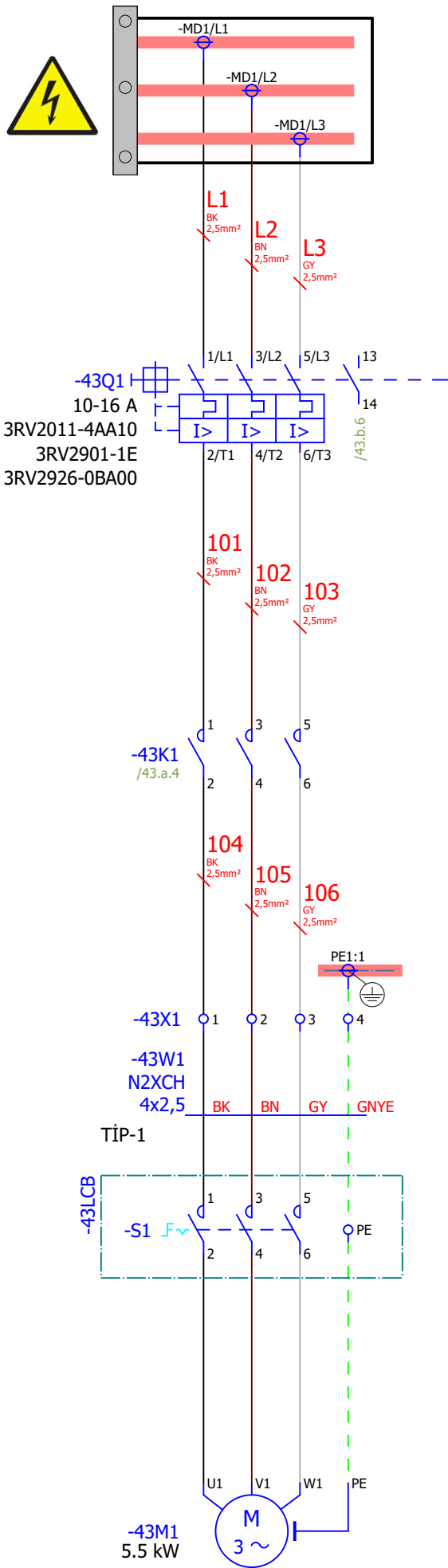

42.c

Page: 43.a

Çizen (Drawing)	Kontrol (Control)	USIA	Kontrol (Control)	esan	Tag Number	Lokasyon	Sayfa açıklaması (Page description)	Proje adı (Project name)	=
Necip SERT Proje Tasarım	Ufuk GÜLÇEN Proje Sorumlusu		Önder KURT Proje Sorumlusu		ESTR-MLS-DRY2-VIB001-xM1-	MCC-27.6	Eski Öğütme Siloları Besleme Vidası	Esan Eczacıbaşı Milas ÜYS YENİ KURUTMA	+ MCC
									Next page: 43.b
									Previous page: 42.c





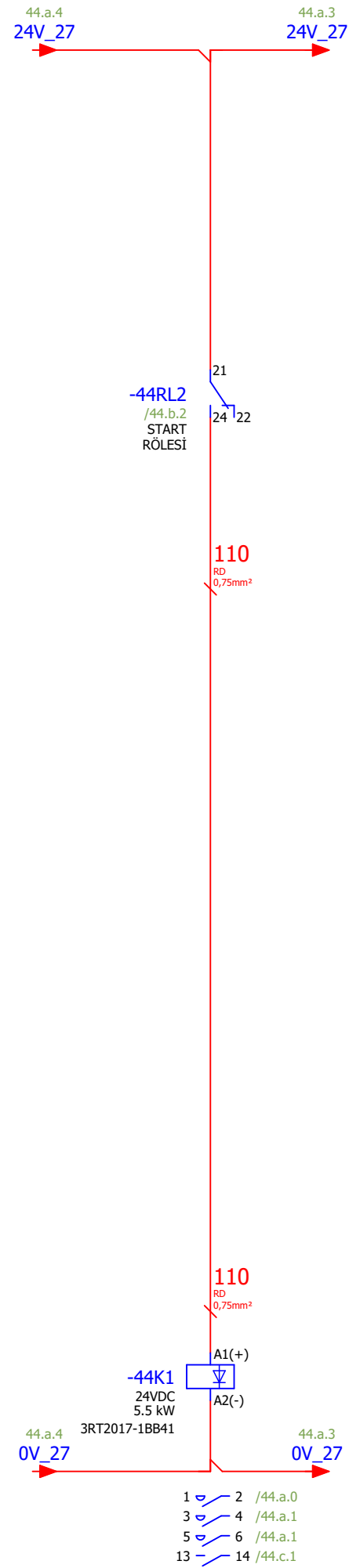
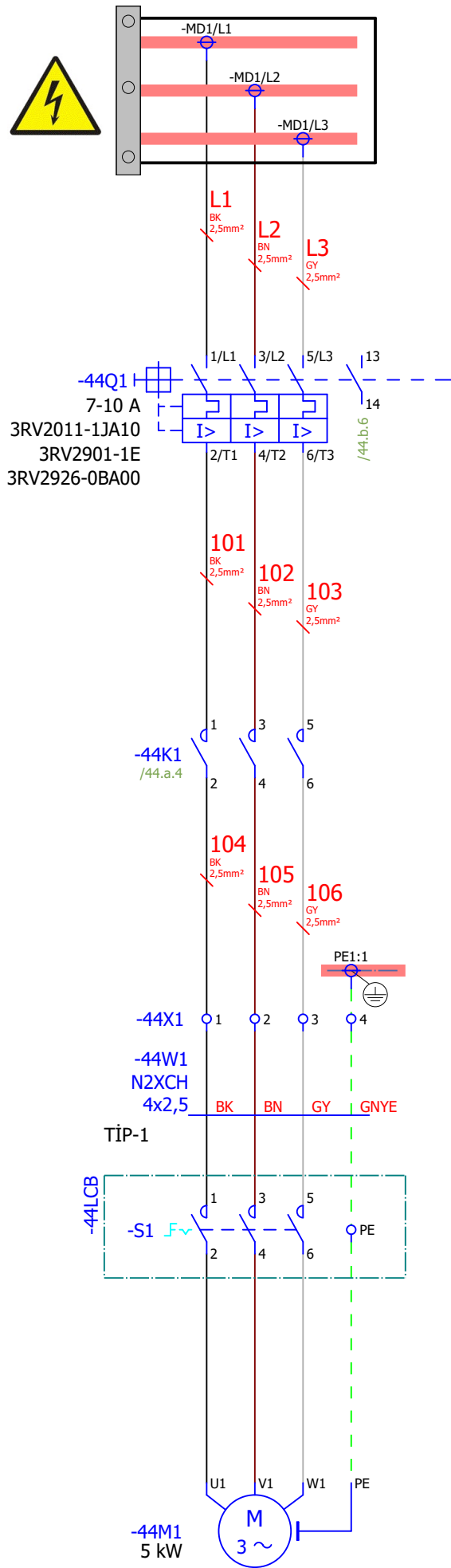

43.c

Page: 44.a

Çizen (Drawing)	Kontrol (Control)	USIA	Kontrol (Control)	esan	Tag Number	Lokasyon	Sayfa açıklaması (Page description)	Proje adı (Project name)	=
Necip SERT Proje Tasarım	Ufuk GÜLÇEN Proje Sorumlusu		Önder KURT Proje Sorumlusu		ESTR-MLS-GRI2-SIL002-xM1-	MCC-27.7	Vibro Besleyici	Esan Eczacıbaşı Milas ÜYS YENİ KURUTMA	MCC
									Next page: 44.b
									Previous page: 43.c

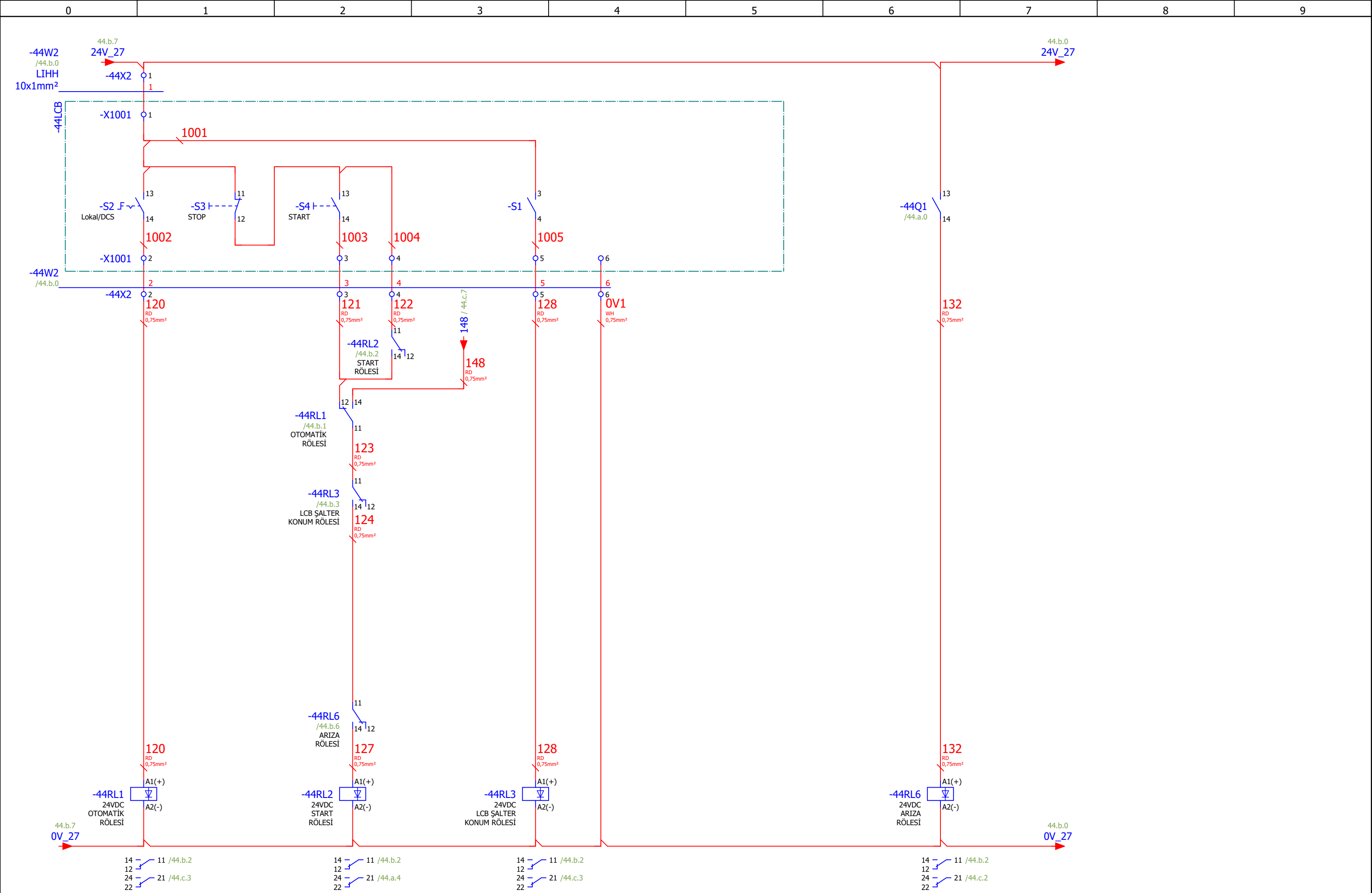

Çizen (Drawing)	Kontrol (Control)	USIA	Kontrol (Control)	Tag Number	Lokasyon	Sayfa açıklaması (Page description)	Proje adı (Project name)
Necip SERT Proje Tasarım	Ufuk GÜLÇEN Proje Sorumlusu		Önder KURT Proje Sorumlusu	ESTR-MLS-GRI2-SIL002-xM1-	MCC-27.7	Vibro Besleyici	Esan Eczacıbaşı Milas ÜYS YENİ KURUTMA
=							
+							
Next page: 44.c							
Previous page: 44.a							





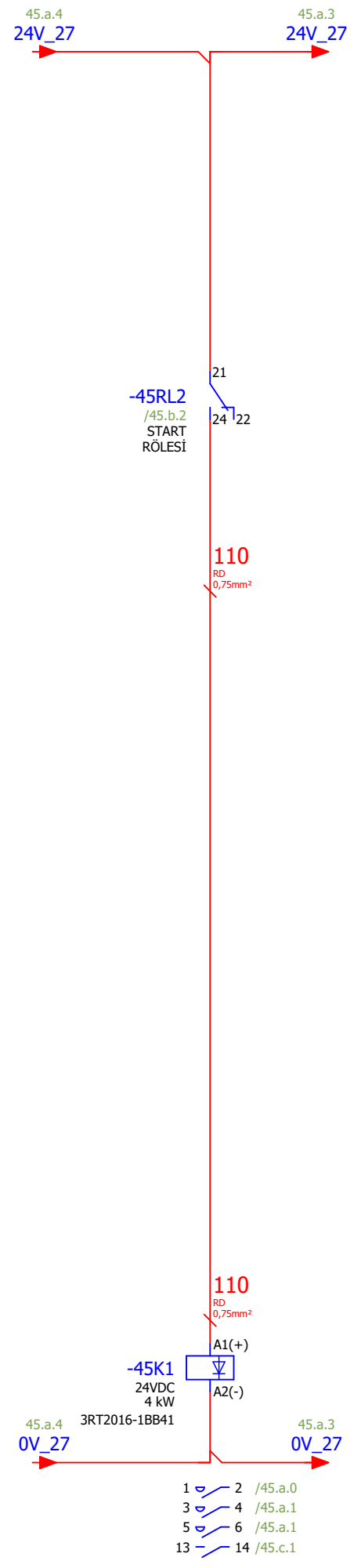
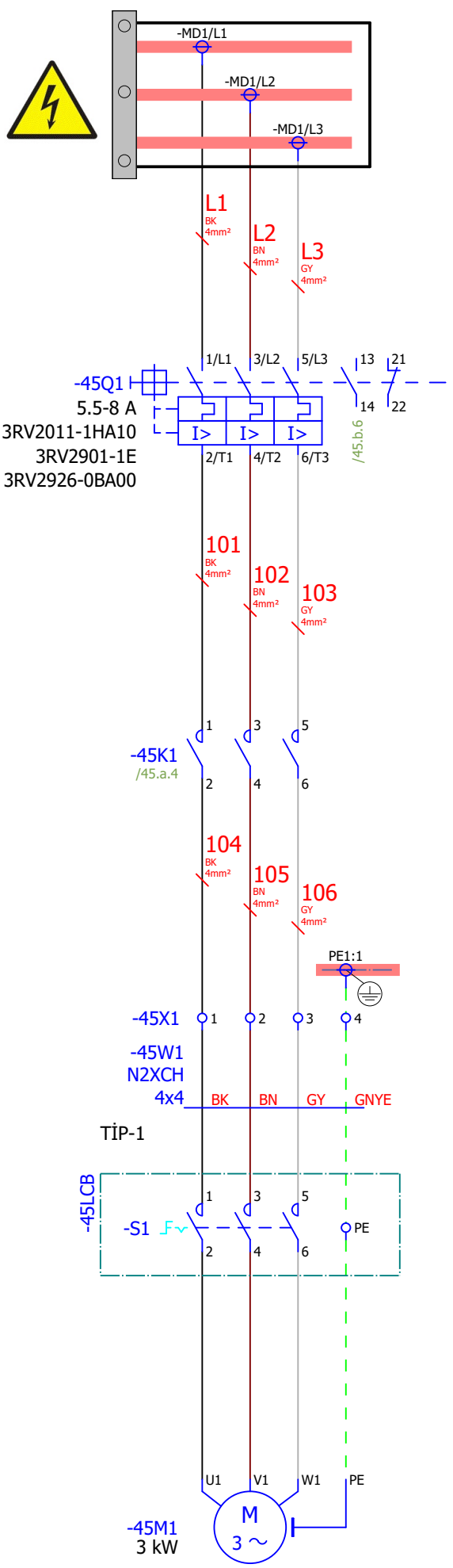

44.c

Page: 45.a

Cizen (Drawing)	Kontrol (Control)	USIA	Kontrol (Control)	esan	Tag Number	Lokasyon	Sayfa açıklaması (Page description)	Proje adı (Project name)	=
Necip SERT Proje Tasarım	Ufuk GÜLÇEN Proje Sorumlusu		Önder KURT Proje Sorumlusu		ESTR-MLS-KUR2-CNV006-xM1-	MCC-27.8	İnce Öğütme Besleme Bandı	Esan Eczacıbaşı Milas ÜYS YENİ KURUTMA	+ Next page: Previous page:
									MCC 45.b 44.c

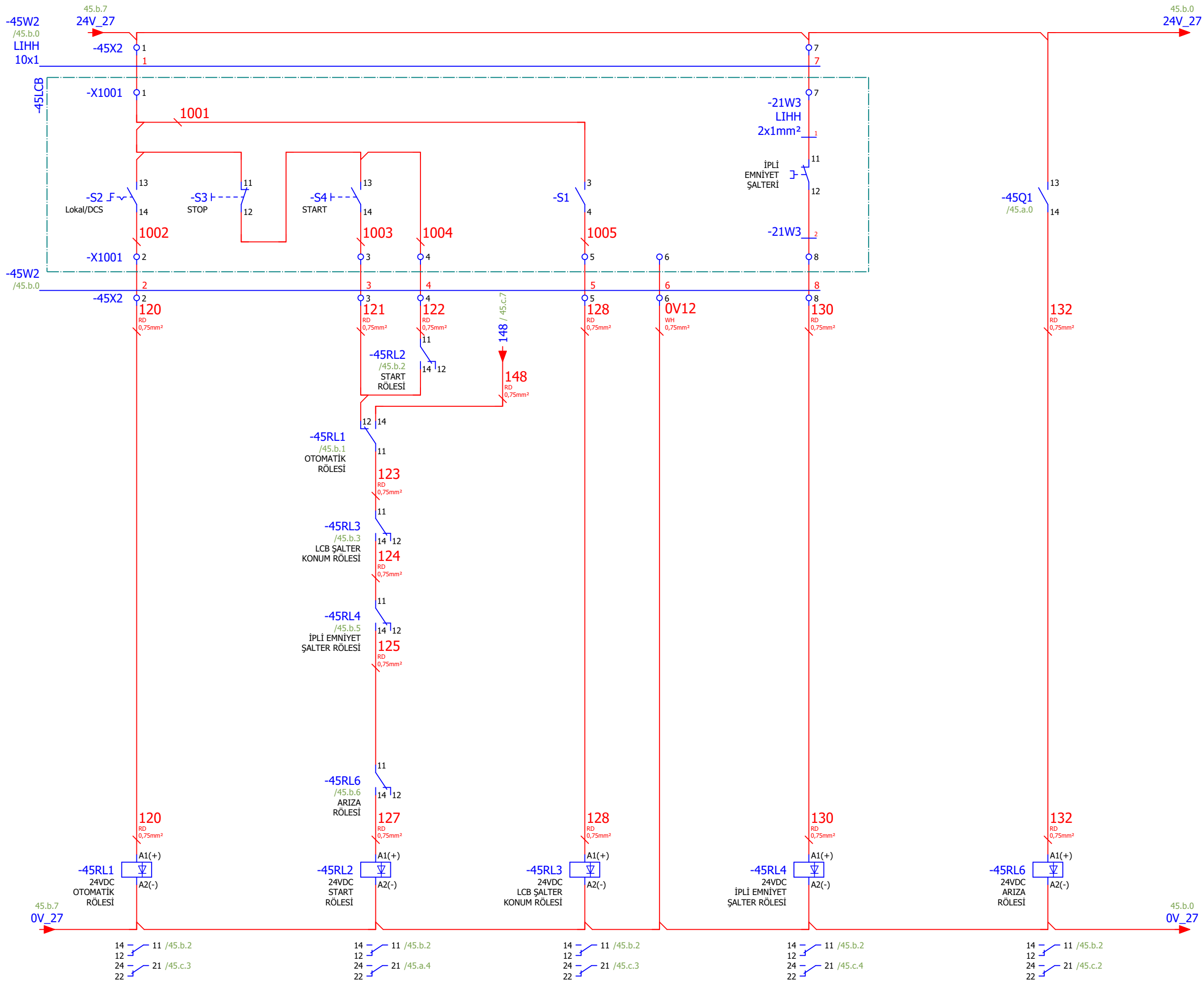

45.a

Page: 45.b

Çizen (Drawing)	Kontrol (Control)	USIA	Kontrol (Control)	Tag Number	Lokasyon	Sayfa açıklaması (Page description)	Proje adı (Project name)
Necip SERT Proje Tasarım	Ufuk GÜLÇEN Proje Sorumlusu		Önder KURT Proje Sorumlusu	ESTR-MLS-KUR2-CNV006-xM1-	MCC-27.8	İnce Öğütme Besleme Bandı	Esan Eczacıbaşı Milas ÜYS YENİ KURUTMA
=							
+							
Next page: 45.c							
Previous page: 45.a							



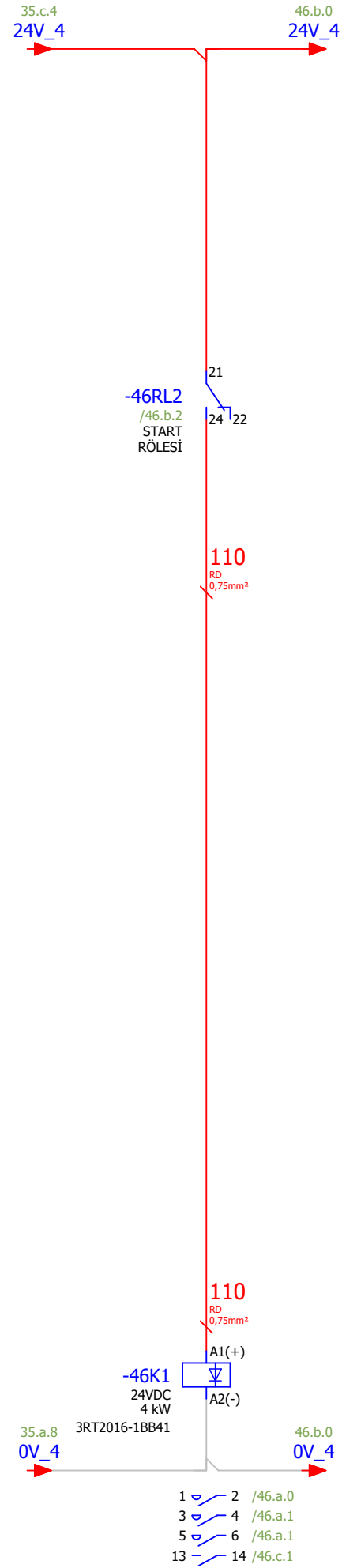
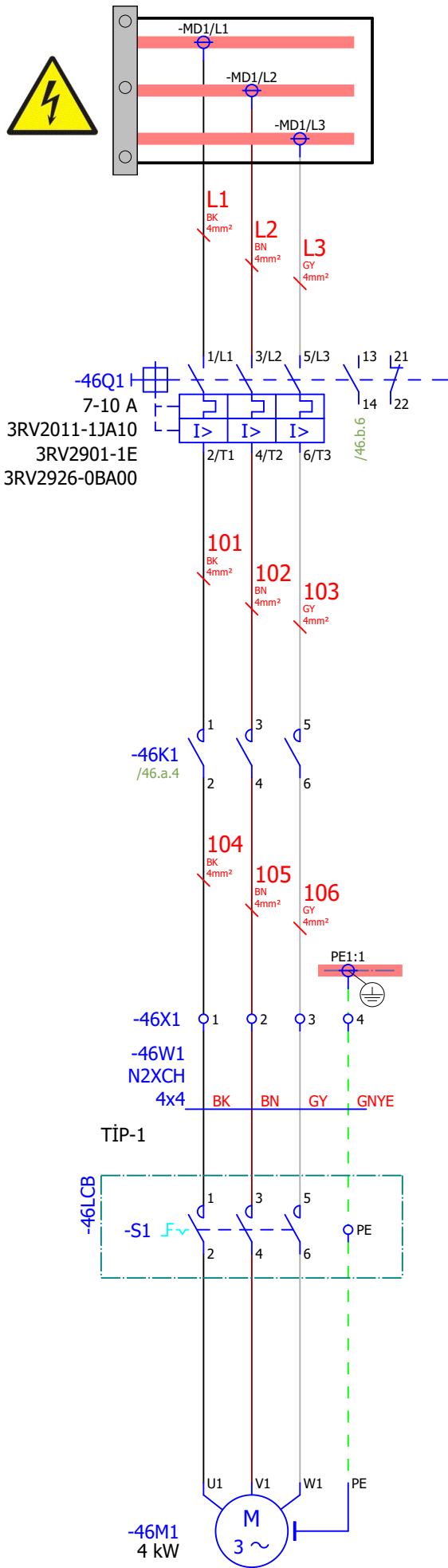

Çizen (Drawing)	Kontrol (Control)	USIA	Kontrol (Control)	esan	Tag Number	Lokasyon	Sayfa açıklaması (Page description)	Proje adı (Project name)	=
Necip SERT Proje Tasarım	Ufuk GÜLÇEN Proje Sorumlusu		Önder KURT Proje Sorumlusu		ESTR-MLS-KUR2-CNV007-xM1-	MCC-4.1	Yeni Öğütme Besleme Bandı	Esan Eczacıbaşı Milas ÜYS YENİ KURUTMA	MCC
									Next page: 46.b
									Previous page: 45.c

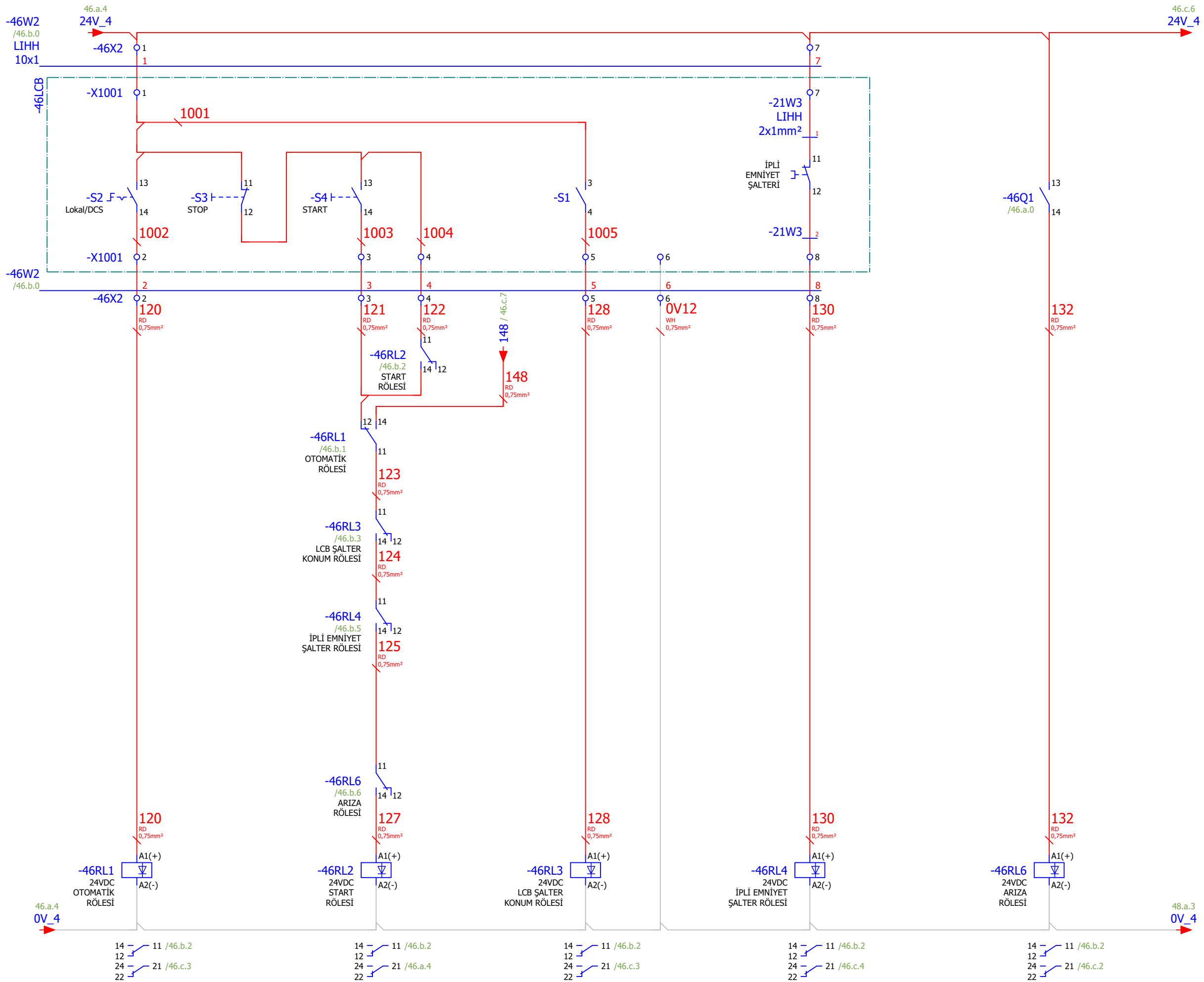

Çizen (Drawing)	Kontrol (Control)	USIA	Kontrol (Control)	Tag Number	Lokasyon	Sayfa açıklaması (Page description)	Proje adı (Project name)
Necip SERT Proje Tasarım	Ufuk GÜLÇEN Proje Sorumlusu		Önder KURT Proje Sorumlusu	ESTR-MLS-KUR2-CNV007-xM1-	MCC-4.1	Yeni Öğütme Besleme Bandı	Esan Eczacıbaşı Milas ÜYS YENİ KURUTMA
							=
							+ MCC
							Next page: 46.c
							Previous page: 46.a



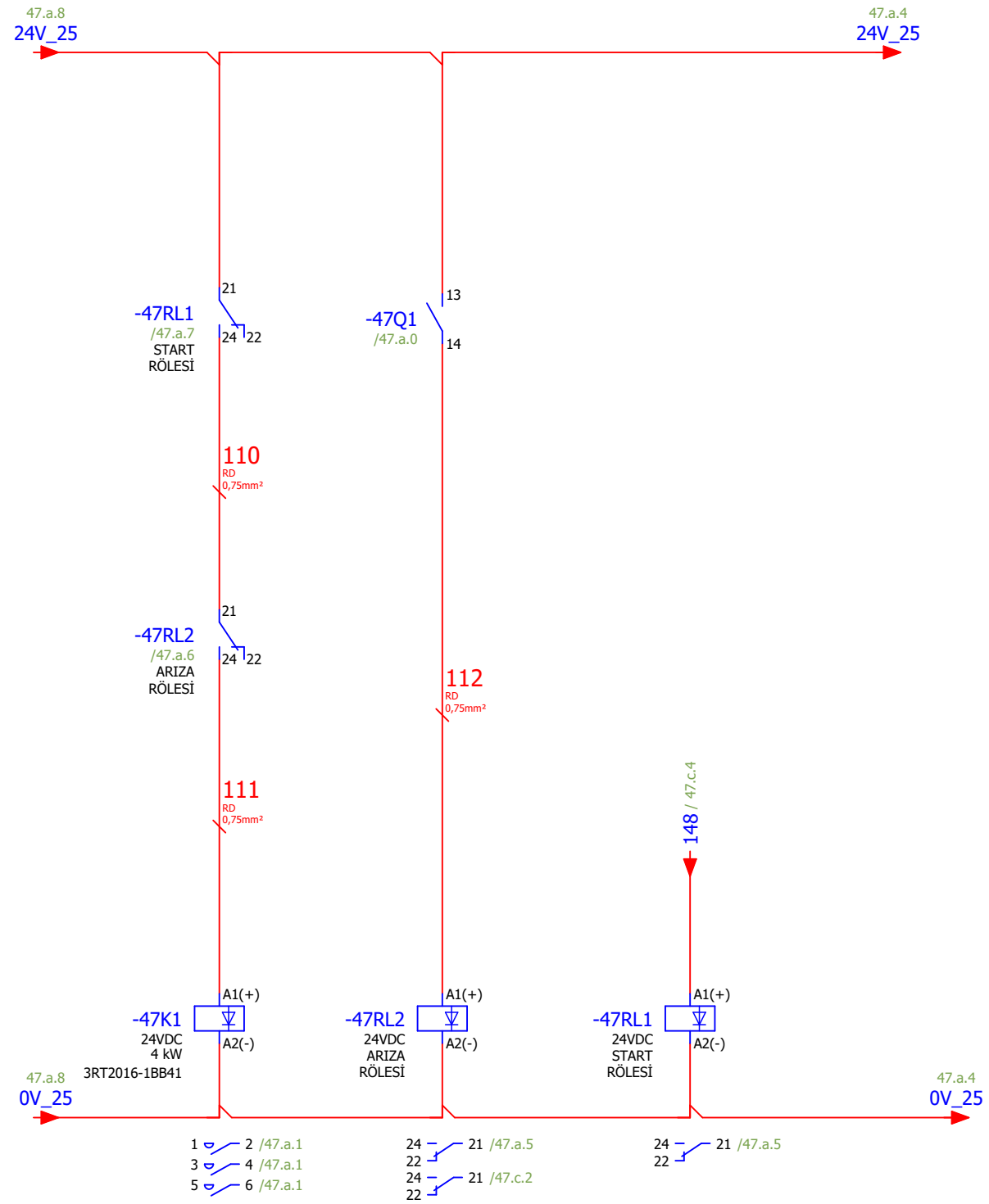
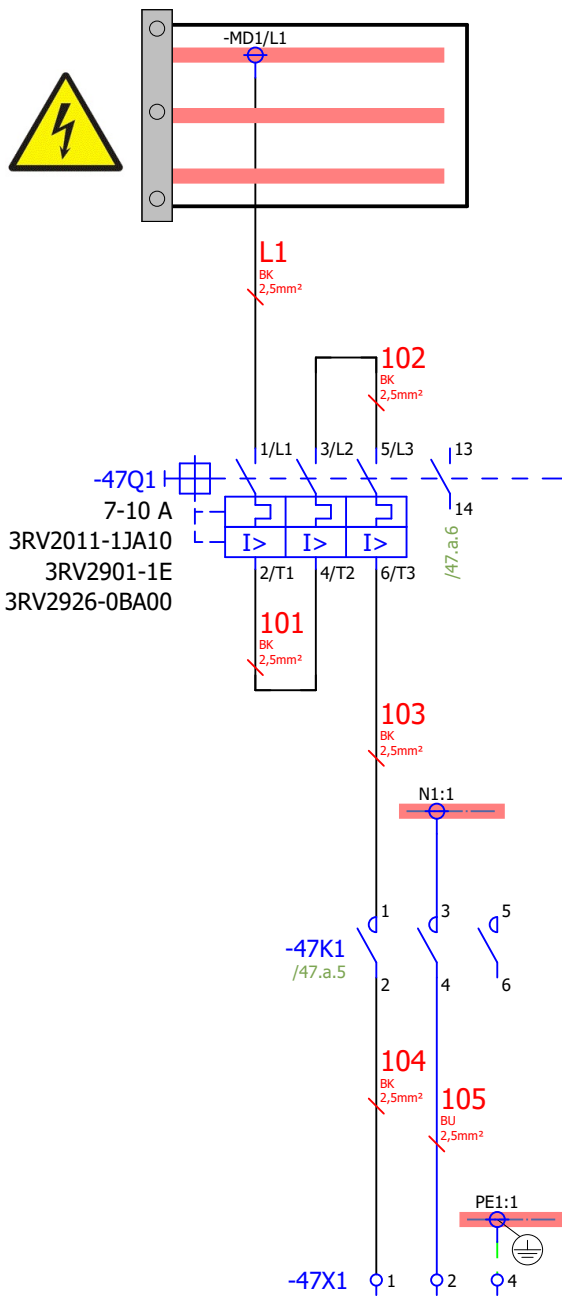

Çizen (Drawing)	Kontrol (Control)	USIA	Kontrol (Control)	esan	Tag Number	Lokasyon	Sayfa açıklaması (Page description)	Proje adı (Project name)	=
Necip SERT Proje Tasarım	Ufuk GÜLÇEN Proje Sorumlusu		Önder KURT Proje Sorumlusu		ESTR-MLS-DRY2-CNV001-XI1	MCC-25.1	Fırın Besleme Bandı Bant Kantarı	Esan Eczacıbaşı Milas ÜYS YENİ KURUTMA	
									+
									MCC
									Next page: 47.c
									Previous page: 46.c



ESTR-MLS-DRY2-CNV001-XI1  
Fırın Besleme Bandı Bant Kantarı  
Çalıştı

ESTR-MLS-DRY2-CNV001-XI1  
Fırın Besleme Bandı Bant Kantarı  
Arıza

ESTR-MLS-DRY2-CNV001-XI1  
Fırın Besleme Bandı Bant Kantarı  
Otomatik Start

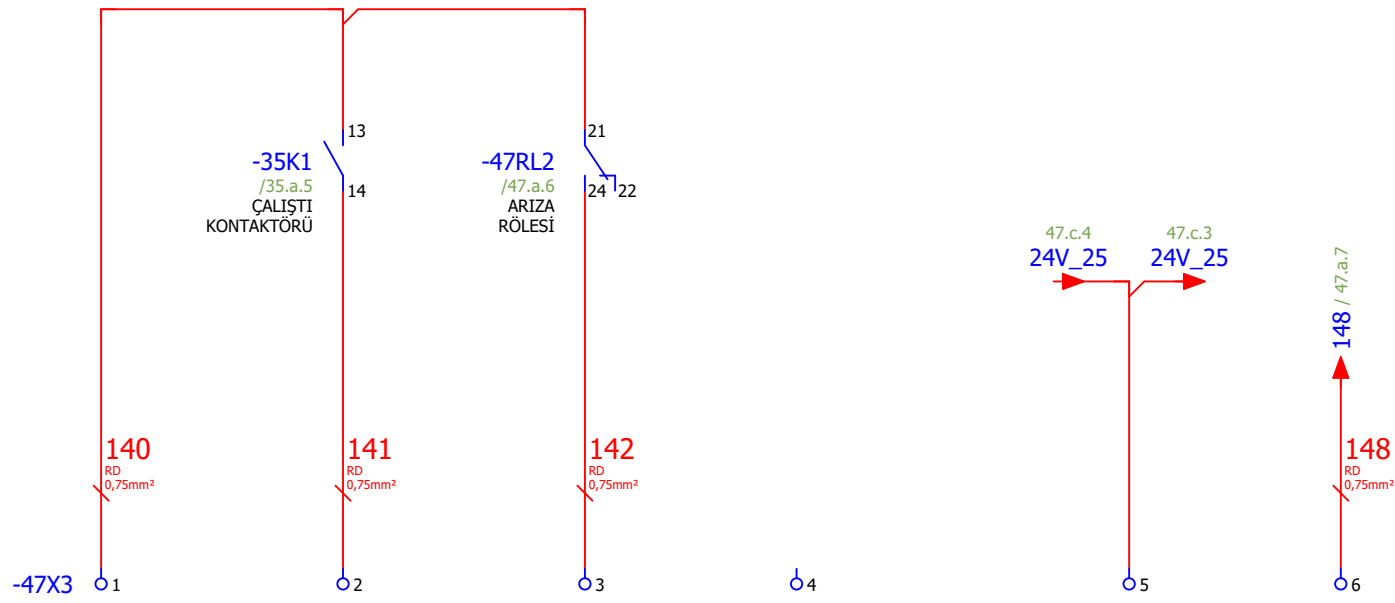

Çizen (Drawing)	Kontrol (Control)	USIA Unique Software at Applications an EPC company	Kontrol (Control)	esan	Tag Number	Lokasyon	Sayfa açıklaması (Page description)	Proje adı (Project name)	=
Necip SERT Proje Tasarım	Ufuk GÜLÇEN Proje Sorumlusu		Önder KURT Proje Sorumlusu		ESTR-MLS-DRY2-CNV001-XI1	MCC-25.1	Fırın Besleme Bandı Bant Kantarı	Esan Eczacıbaşı Milas ÜYS YENİ KURUTMA	
									+ MCC
									Next page: 48.a
									Previous page: 47.a

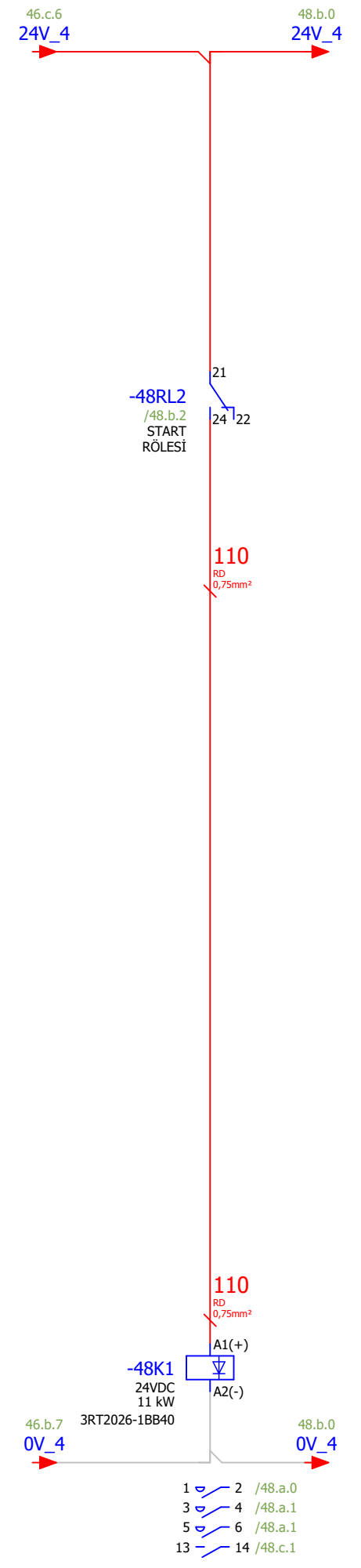
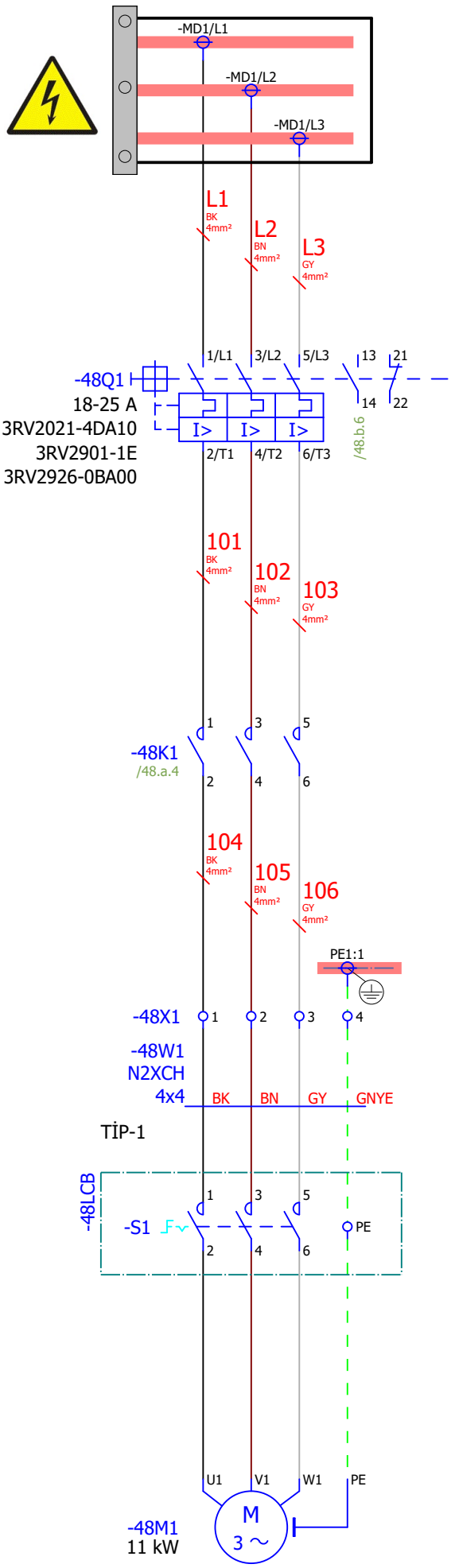

47.c

Page: 48.a

Çizen (Drawing)	Kontrol (Control)	USIA	Kontrol (Control)	esan	Tag Number	Lokasyon	Sayfa açıklaması (Page description)	Proje adı (Project name)	=
Necip SERT Proje Tasarım	Ufuk GÜLÇEN Proje Sorumlusu		Önder KURT Proje Sorumlusu		ESTR-MLS-DRY2-CNV042-XM1	MCC-4.2	Bant motoru	Esan Eczacıbaşı Milas ÜYS YENİ KURUTMA	
									+
									Next page: 48.b
									Previous page: 47.c

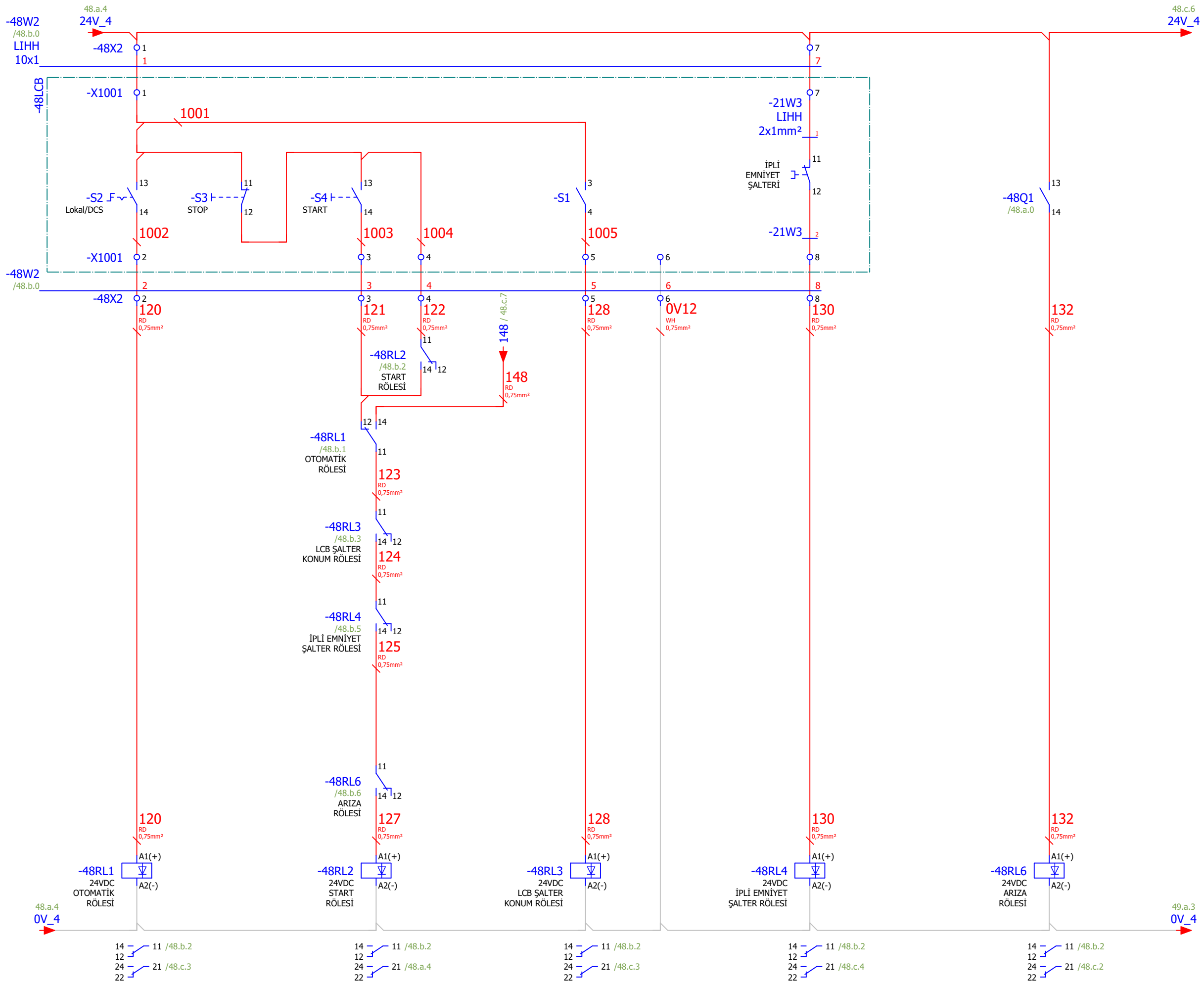

Çizen (Drawing)	Kontrol (Control)	USIA	Kontrol (Control)	Tag Number	Lokasyon	Sayfa açıklaması (Page description)	Proje adı (Project name)
Necip SERT Proje Tasarım	Ufuk GÜLÇEN Proje Sorumlusu		Önder KURT Proje Sorumlusu	ESTR-MLS-DRY2-CNV042-XM1	MCC-4.2	Bant motoru	Esan Eczacıbaşı Milas ÜYS YENİ KURUTMA
=							
+							
Next page: 48.c							
Previous page: 48.a							



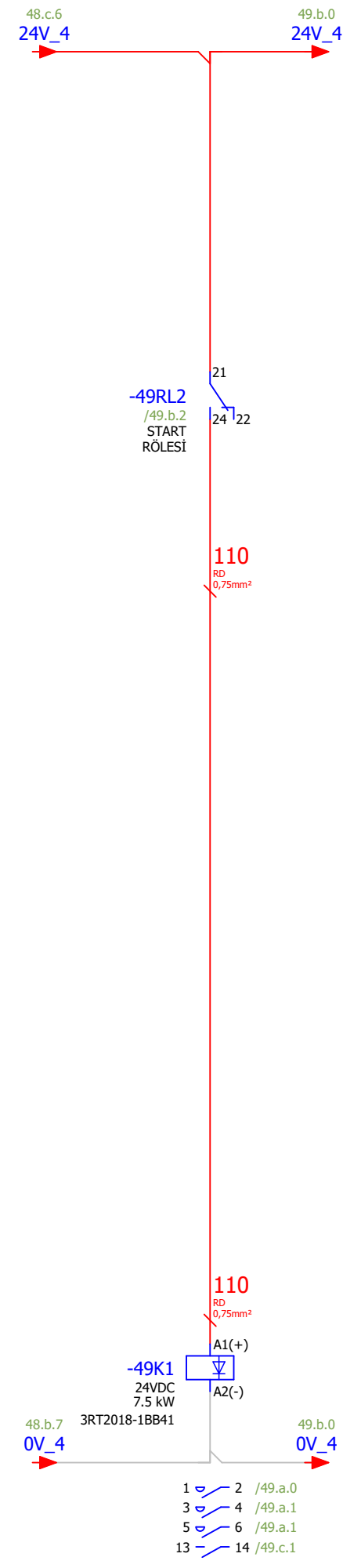
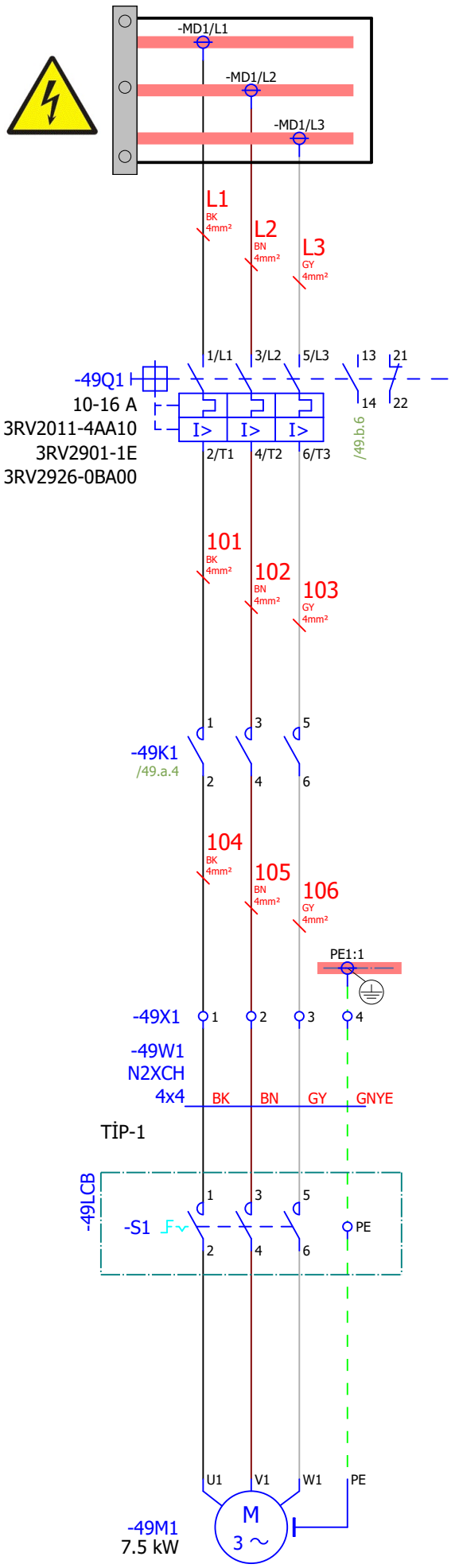

Çizen (Drawing)	Kontrol (Control)
Necip SERT Proje Tasarım	Ufuk GÜLÇEN Proje Sorumlusu



Kontrol (Control)
Önder KURT Proje Sorumlusu



Tag Number
ESTR-MLS-DRY2-CNV043-XM1

Lokasyon
<b>MCC-4.3</b>

Sayfa açıklaması (Page description)
Silo Besleme Bant motoru

Proje adı (Project name)
Esan Eczacıbaşı Milas ÜYS YENİ KURUTMA

=	
+	MCC
Next page:	49.b
Previous page:	48.c

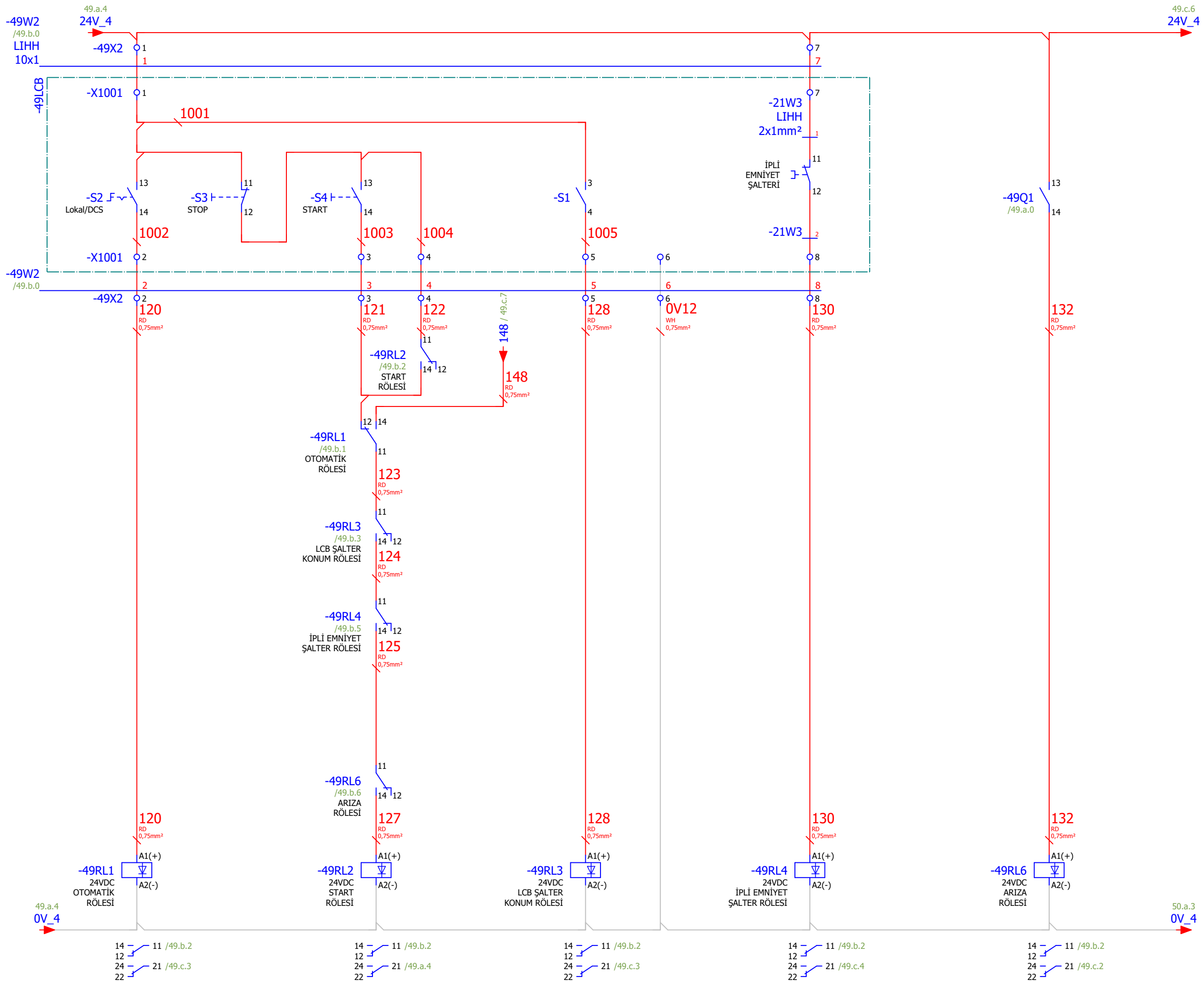

Çizen (Drawing)	Kontrol (Control)	USIA	Kontrol (Control)	Tag Number	Lokasyon	Sayfa açıklaması (Page description)	Proje adı (Project name)
Necip SERT Proje Tasarım	Ufuk GÜLÇEN Proje Sorumlusu		Önder KURT Proje Sorumlusu	ESTR-MLS-DRY2-CNV043-XM1	MCC-4.3	Silo Besleme Bant motoru	Esan Eczacıbaşı Milas ÜYS YENİ KURUTMA
=							
+							
Next page: 49.c							
Previous page: 49.a							



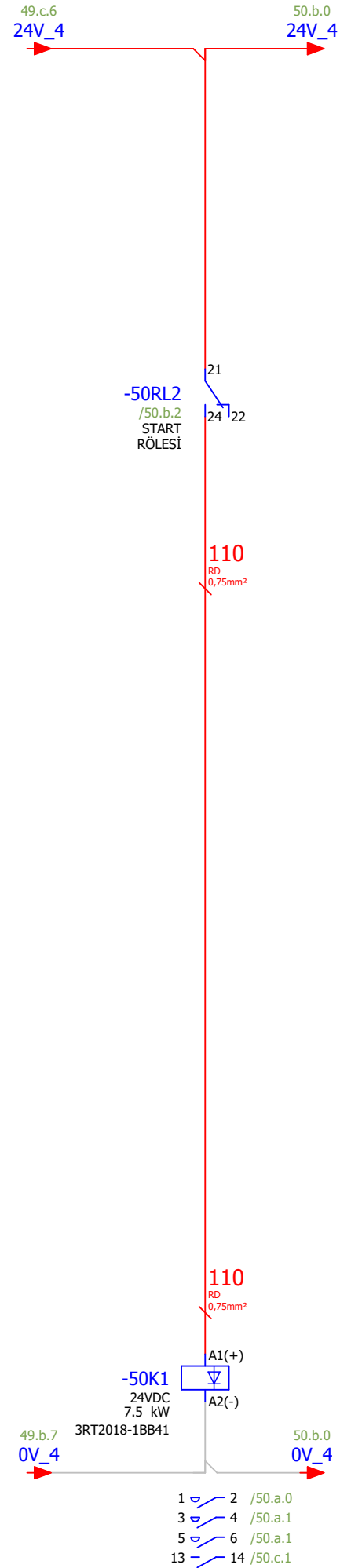
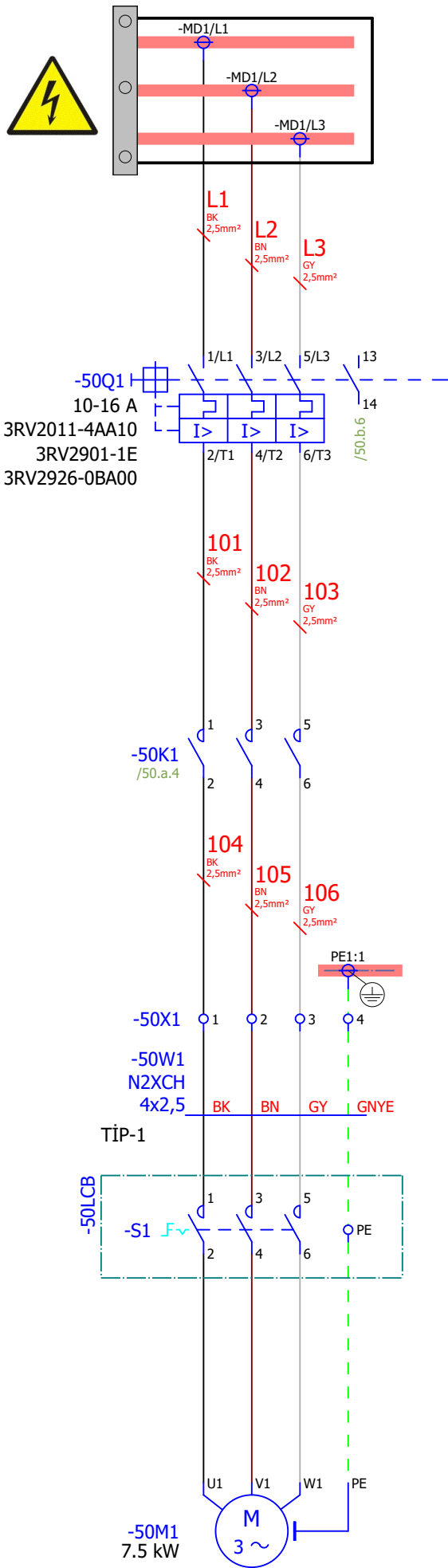

Çizen (Drawing)	Kontrol (Control)	USIA	Kontrol (Control)	esan	Tag Number	Lokasyon	Sayfa açıklaması (Page description)	Proje adı (Project name)	=
Necip SERT Proje Tasarım	Ufuk GÜLÇEN Proje Sorumlusu		Önder KURT Proje Sorumlusu		ESTR-MLS-DRY2-ELV008-XM1	MCC-4.4	Elevatör	Esan Eczacıbaşı Milas ÜYS YENİ KURUTMA	+ MCC
									Next page: 50.b
									Previous page: 49.c



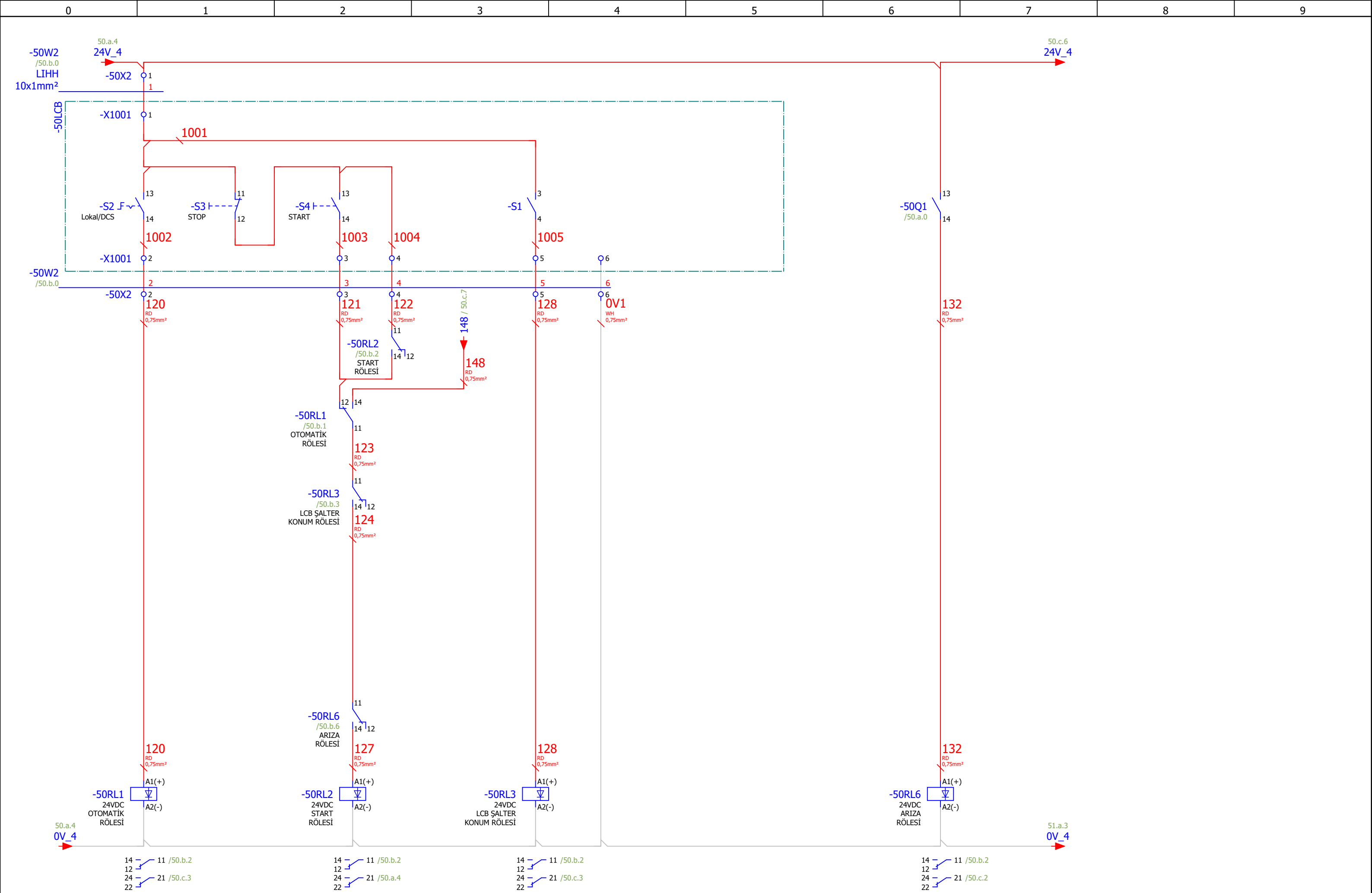

Çizen (Drawing)	Kontrol (Control)	USIA Unique Software at Applications an EPC company	Kontrol (Control)	esan	Tag Number	Lokasyon	Sayfa açıklaması (Page description)	Proje adı (Project name)	=
Necip SERT Proje Tasarım	Ufuk GÜLÇEN Proje Sorumlusu		Önder KURT Proje Sorumlusu		ESTR-MLS-DRY2-ELV008-XM1	MCC-4.4	Elevatör	Esan Eczacıbaşı Milas ÜYS YENİ KURUTMA	+ MCC

ESTR-MLS-DRY2-ELV008-XM1  
Elevatör  
Çalıştı

ESTR-MLS-DRY2-ELV008-XM1  
Elevatör  
Arıza

ESTR-MLS-DRY2-ELV008-XM1  
Elevatör  
Lokal Remote

ESTR-MLS-DRY2-ELV008-XM1  
Elevatör  
Bakım Şalteri

ESTR-MLS-DRY2-ELV008-XM1  
Elevatör  
Otomatik Start

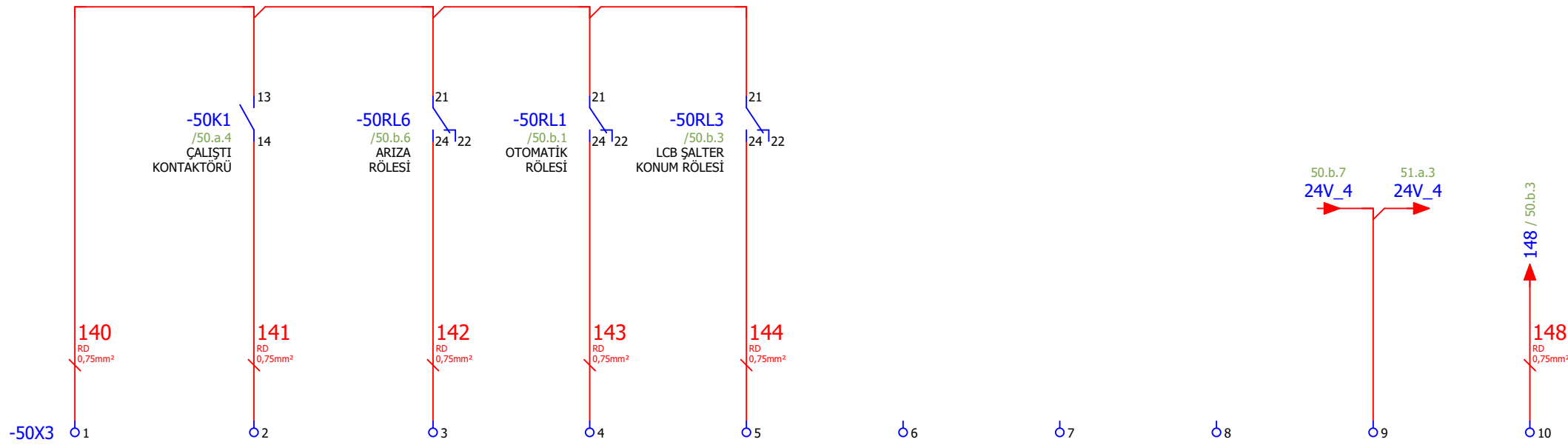

Çizen (Drawing)	Kontrol (Control)	USIA Unique Software Applications an EPC company	Kontrol (Control)	esan	Tag Number	Lokasyon	Sayfa açıklaması (Page description)	Proje adı (Project name)	=
Necip SERT Proje Tasarım	Ufuk GÜLÇEN Proje Sorumlusu		Önder KURT Proje Sorumlusu		ESTR-MLS-DRY2-ELV008-XM1	MCC-4.4	Elevatör	Esan Eczacıbaşı Milas ÜYS YENİ KURUTMA	+ MCC
									Next page: 51.a
									Previous page: 50.b

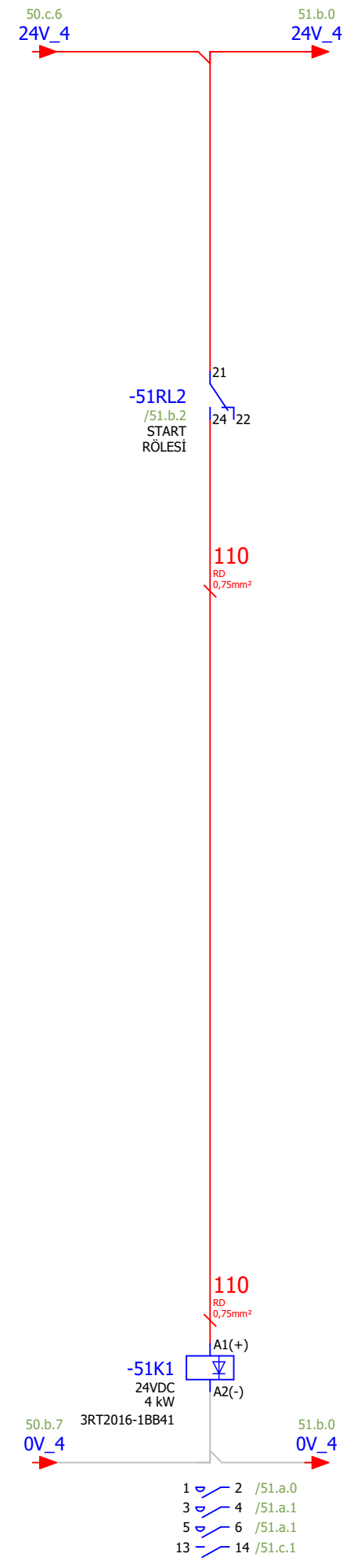
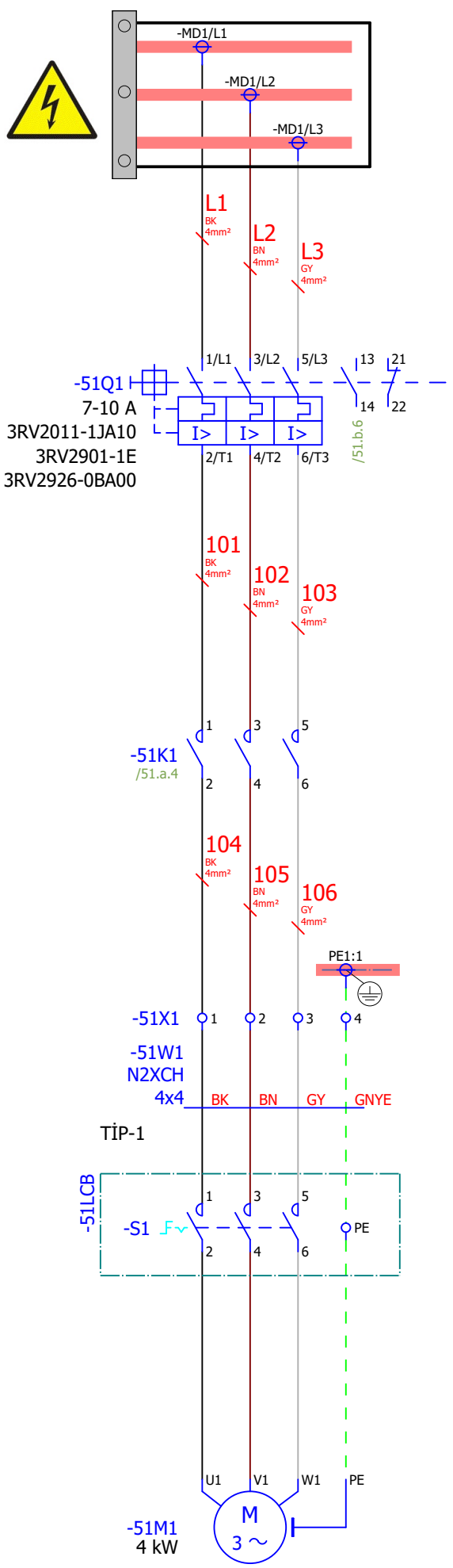

50.c

Page: 51.a

Çizen (Drawing)	Kontrol (Control)
Necip SERT Proje Tasarım	Ufuk GÜLÇEN Proje Sorumlusu

	Kontrol (Control)
	Önder KURT Proje Sorumlusu



Tag Number
ESTR-MLS-DRY2-CNV044-XM1

Lokasyon
<b>MCC-4.5</b>

Sayfa açıklaması (Page description)
Elevatör Besleme Bandı

Proje adı (Project name)
Esan Eczacıbaşı Milas ÜYS YENİ KURUTMA

=	
+	MCC
Next page:	51.b
Previous page:	50.c

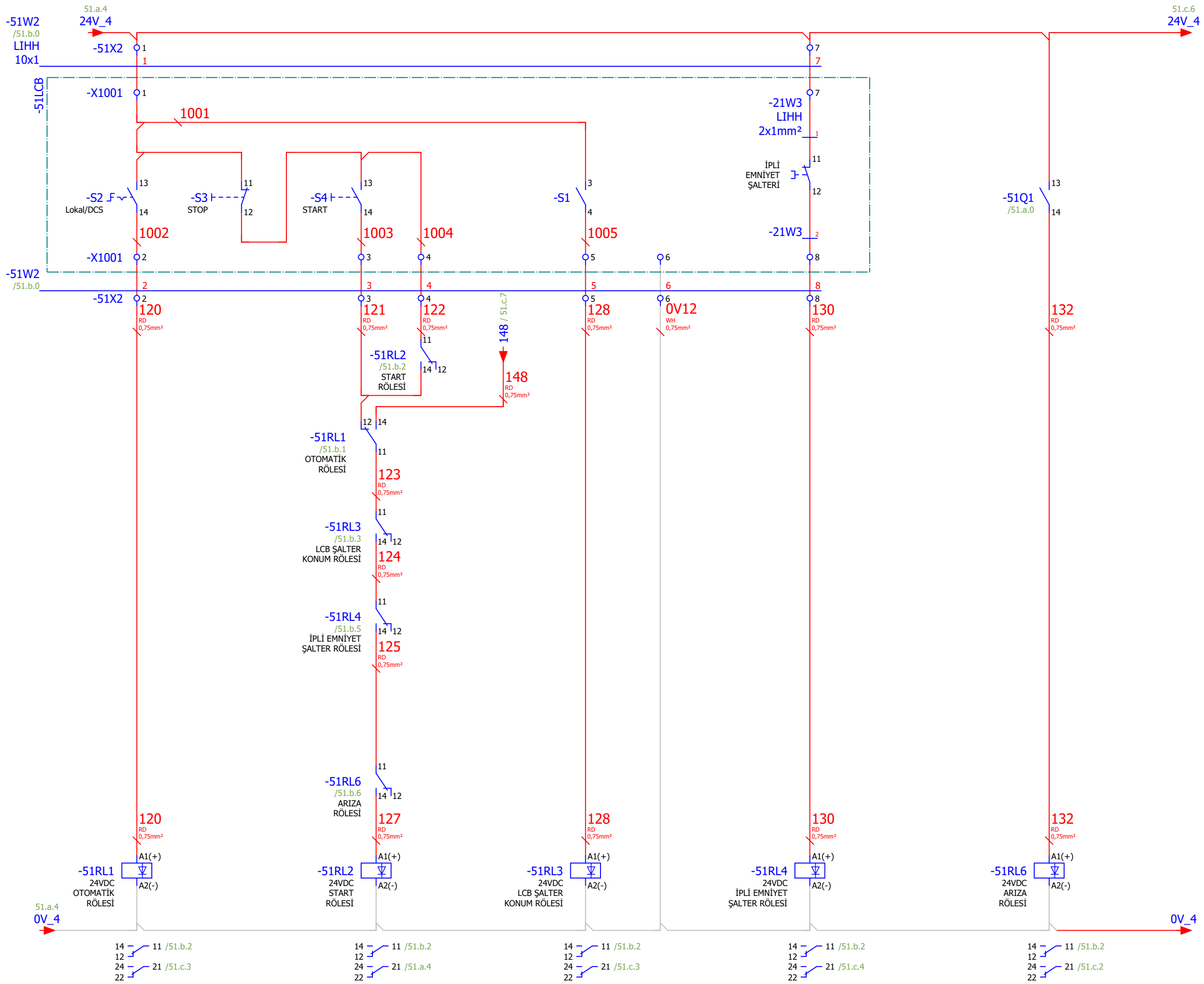

Çizen (Drawing)	Kontrol (Control)	USIA	Kontrol (Control)	Tag Number	Lokasyon	Sayfa açıklaması (Page description)	Proje adı (Project name)
Necip SERT Proje Tasarım	Ufuk GÜLÇEN Proje Sorumlusu		Önder KURT Proje Sorumlusu	ESTR-MLS-DRY2-CNV044-XM1	MCC-4.5	Elevatör Besleme Bandı	Esan Eczacıbaşı Milas ÜYS YENİ KURUTMA
=							
+							
Next page: 51.c							
Previous page: 51.a							





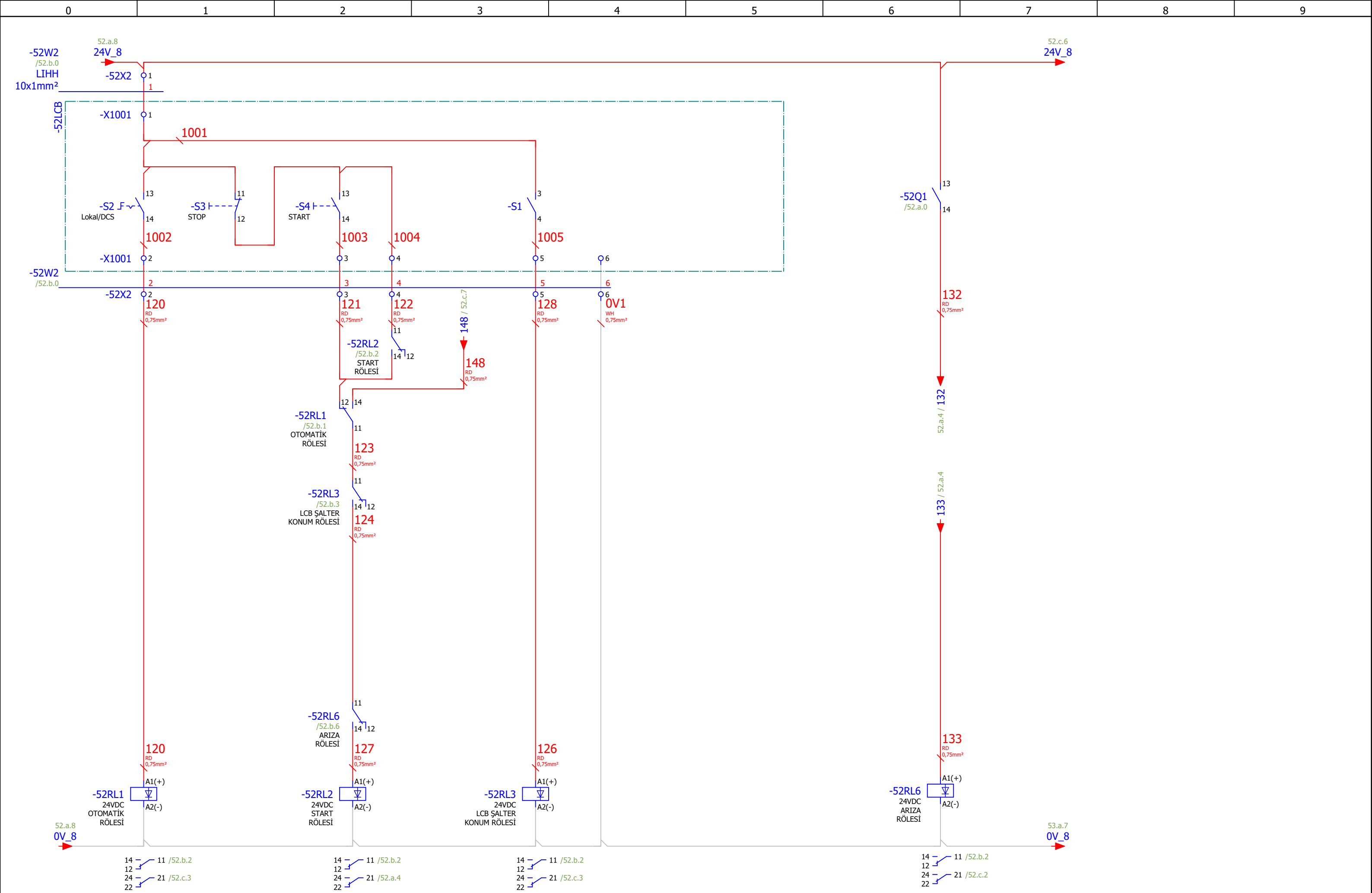

52.a

Page: 52.b

Çizen (Drawing)	Kontrol (Control)	USIA	Kontrol (Control)	Tag Number	Lokasyon	Sayfa açıklaması (Page description)	Proje adı (Project name)
Necip SERT Proje Tasarım	Ufuk GÜLÇEN Proje Sorumlusu		Önder KURT Proje Sorumlusu	ESTR-MLS-DRY2-MSP014-XM1	MCC-8.1	Manyetik Permrol-1-1	Esan Eczacıbaşı Milas ÜYS YENİ KURUTMA
=							
+							
Next page: 52.c							
Previous page: 52.a							





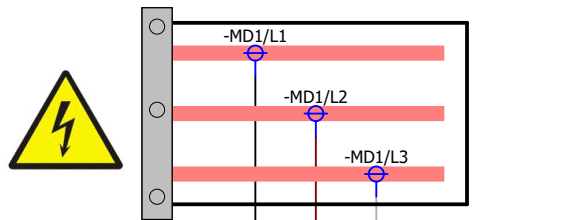

**!!! DİKKAT !!!**  
 MOTOR YOL VERİCİ KORUMA ŞALTERİ  
 HIZ KONTROL (VFD) GÜCÜNE GÖRE SECİLMİŞTİR .  
 MOTOR KORUMA FONKSİYONU  
 HIZ KONTROL (VFD) TARAFINDAN YAPILMAKTADIR .

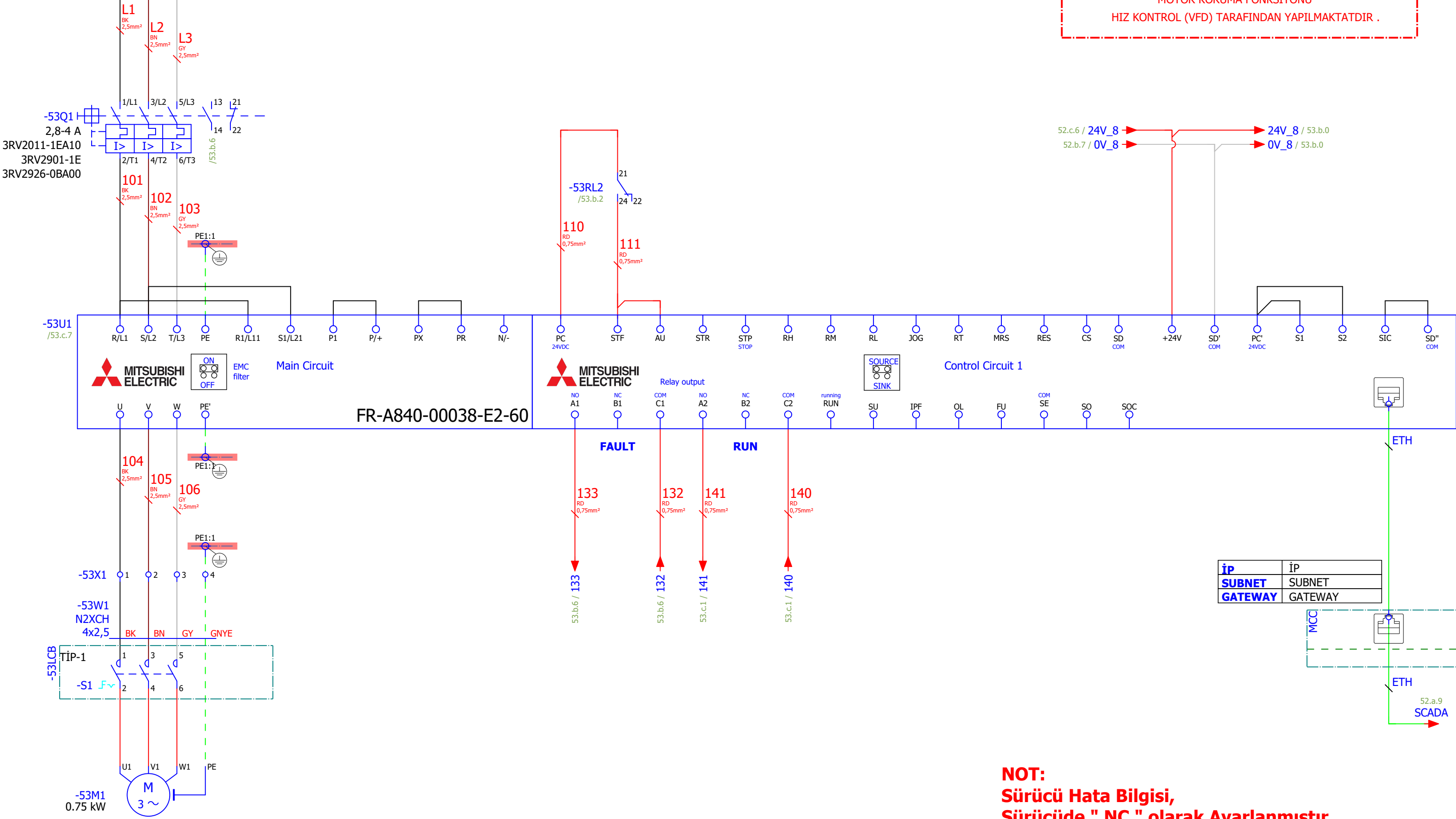

İP	İP
SUBNET	SUBNET
GATEWAY	GATEWAY

**NOT:**  
 Sürücü Hata Bilgisi,  
 Sürücüde " NC " olarak Ayarlanmıştır...

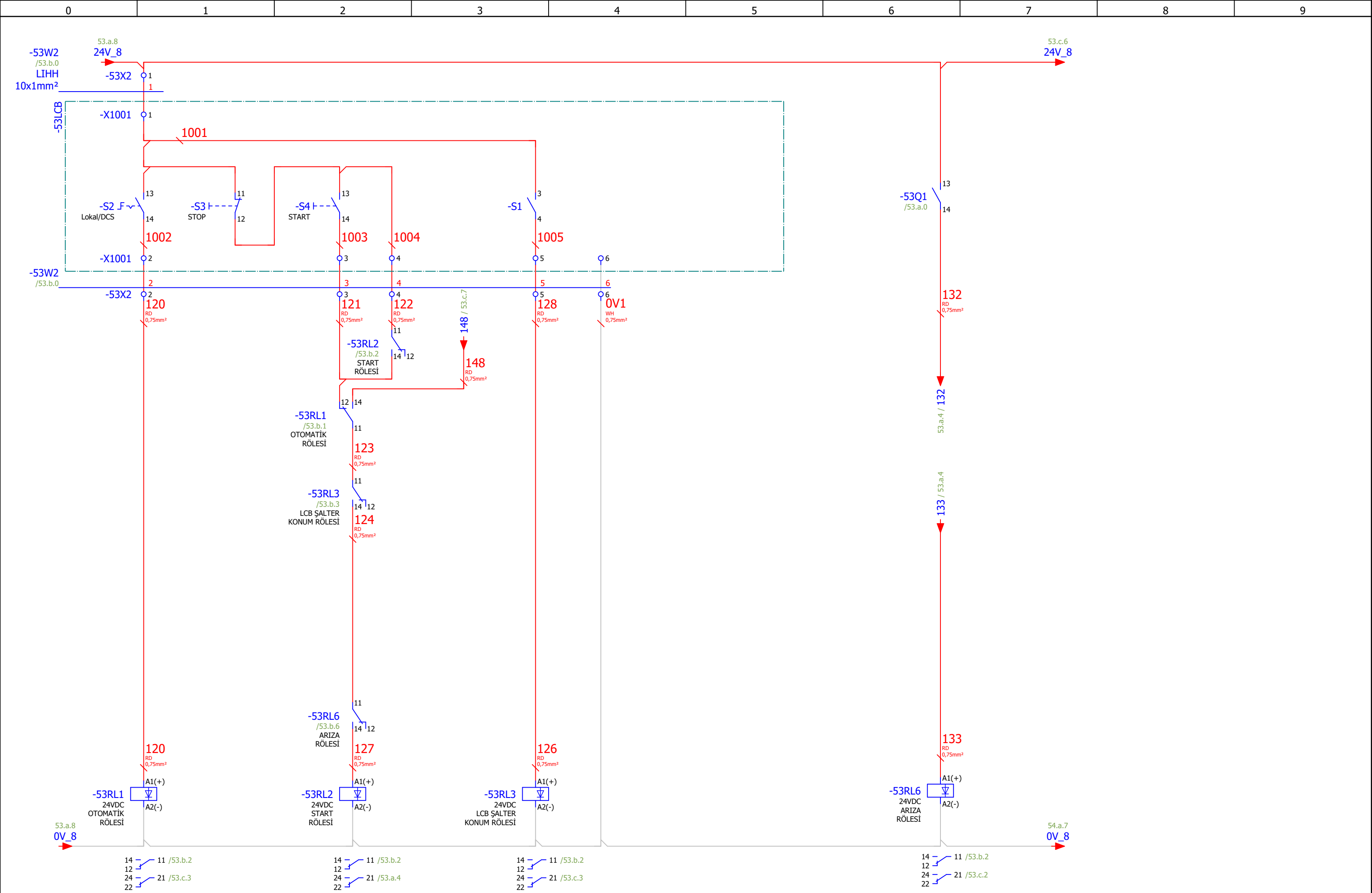

53.a

Page: 53.b

Çizen (Drawing)	Kontrol (Control)	US	Kontrol (Control)	esan	Tag Number	Lokasyon	Sayfa açıklaması (Page description)	Proje adı (Project name)	=
Necip SERT Proje Tasarım	Ufuk GÜLÇEN Proje Sorumlusu		Önder KURT Proje Sorumlusu		ESTR-MLS-DRY2-MSP014-XM2	MCC-8.2	Manyetik Permrol-1-2	Esan Eczacıbaşı Milas ÜYS YENİ KURUTMA	+ MCC
									Next page: 53.c
									Previous page: 53.a





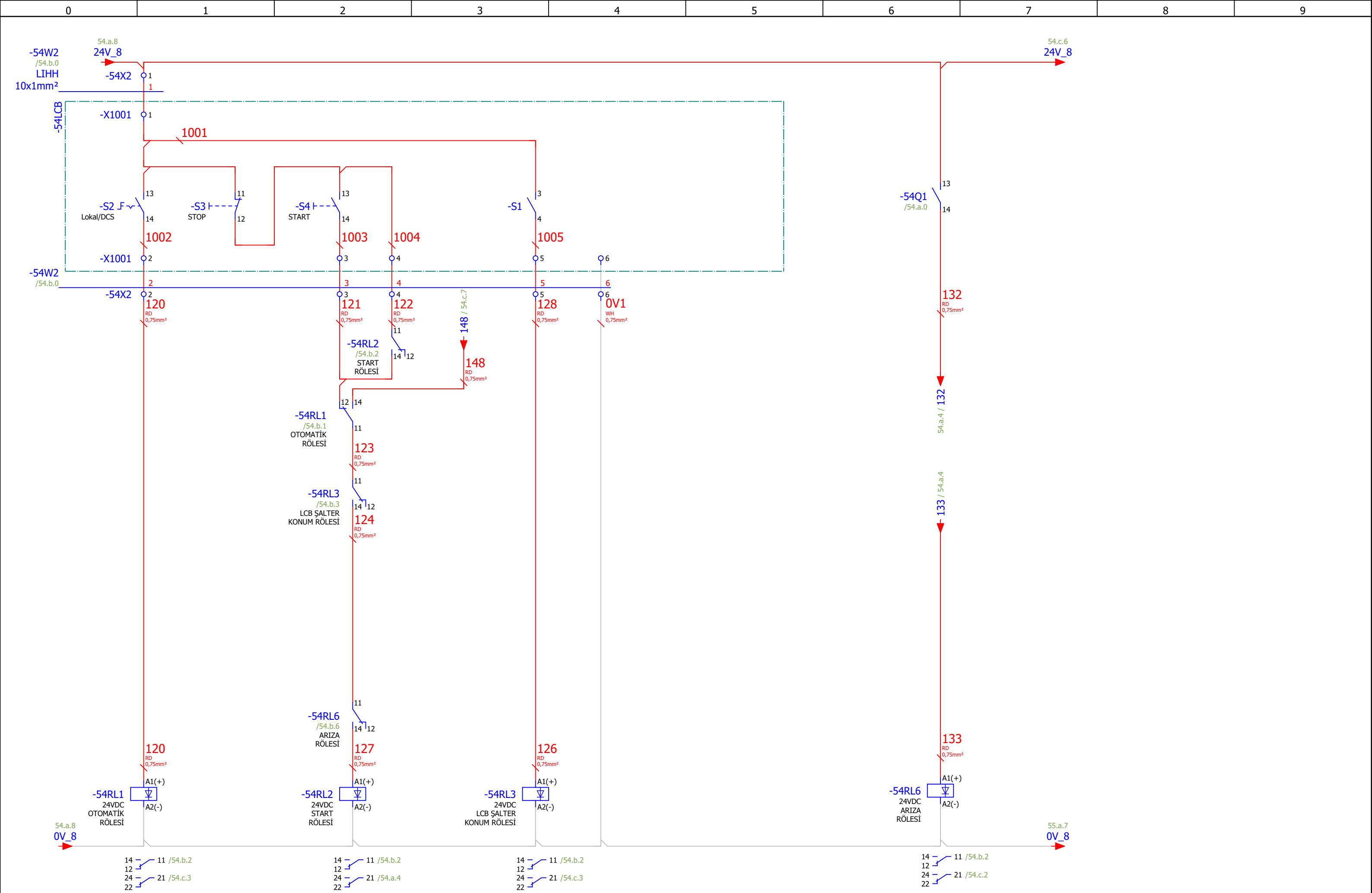

Çizen (Drawing)	Kontrol (Control)	USIA	Kontrol (Control)	Tag Number	Lokasyon	Sayfa açıklaması (Page description)	Proje adı (Project name)
Necip SERT Proje Tasarım	Ufuk GÜLÇEN Proje Sorumlusu		Önder KURT Proje Sorumlusu	ESTR-MLS-DRY2-MSP014-XM3	MCC-8.3	Manyetik Permrol-1-3	Esan Eczacıbaşı Milas ÜYS YENİ KURUTMA
=							
+							
Next page: 54.c							
Previous page: 54.a							



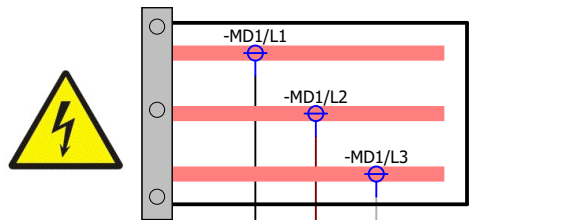

**!!! DİKKAT !!!**  
 MOTOR YOL VERİCİ KORUMA ŞALTERİ  
 HIZ KONTROL (VFD) GÜCÜNE GÖRE SEÇİLMİŞTİR .  
 MOTOR KORUMA FONKSİYONU  
 HIZ KONTROL (VFD) TARAFINDAN YAPILMAKTADIR .

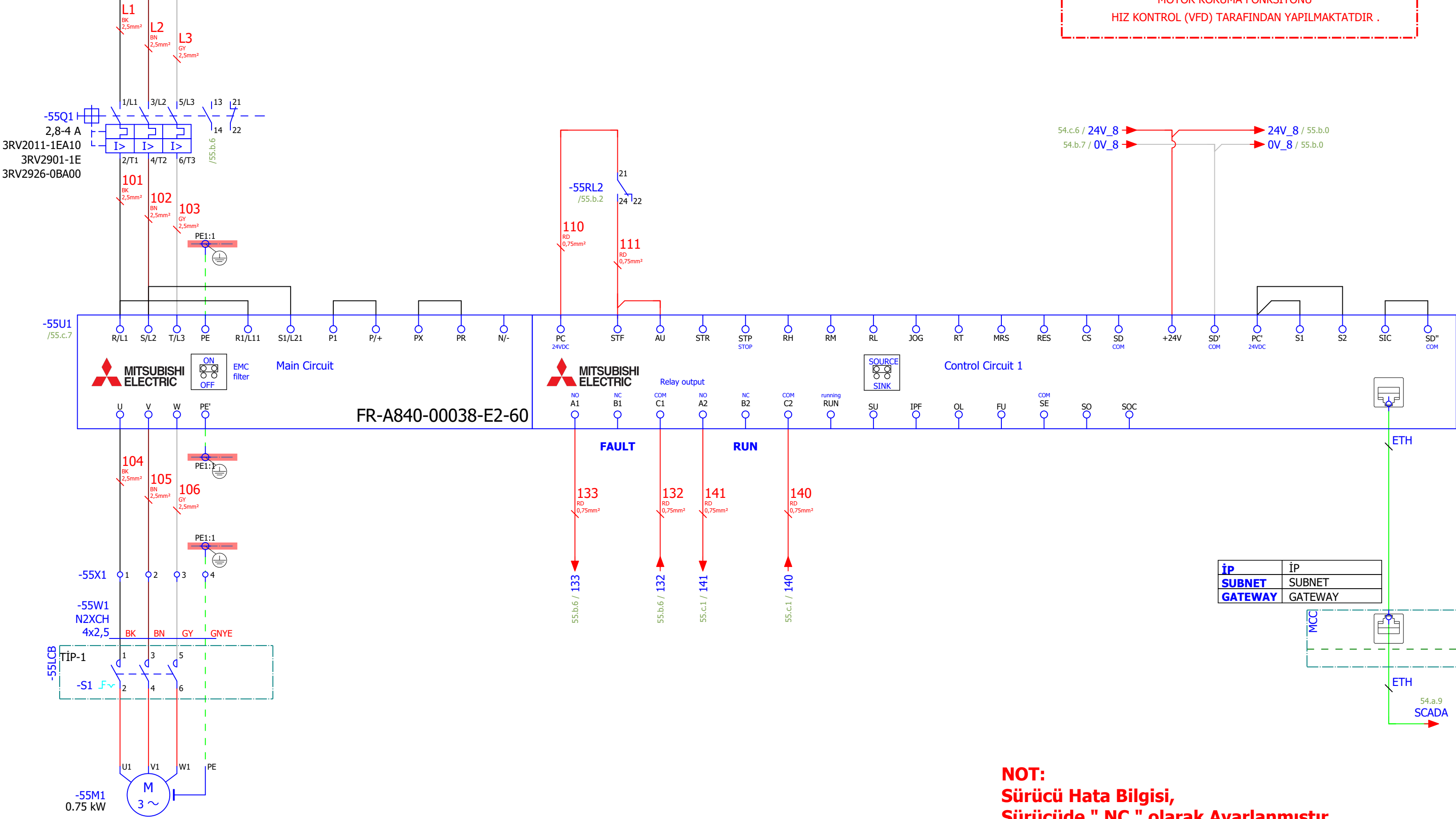

İP	İP
SUBNET	SUBNET
GATEWAY	GATEWAY

**NOT:**  
 Sürücü Hata Bilgisi,  
 Sürücüde " NC " olarak Ayarlanmıştır...







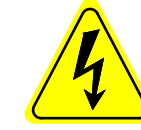

**!!! DİKKAT !!!**  
MOTOR YOL VERİCİ KORUMA ŞALTERİ  
HIZ KONTROL (VFD) GÜCÜNE GÖRE SEÇİLMİŞTİR .  
MOTOR KORUMA FONKSİYONU  
HIZ KONTROL (VFD) TARAFINDAN YAPILMAKTADIR .

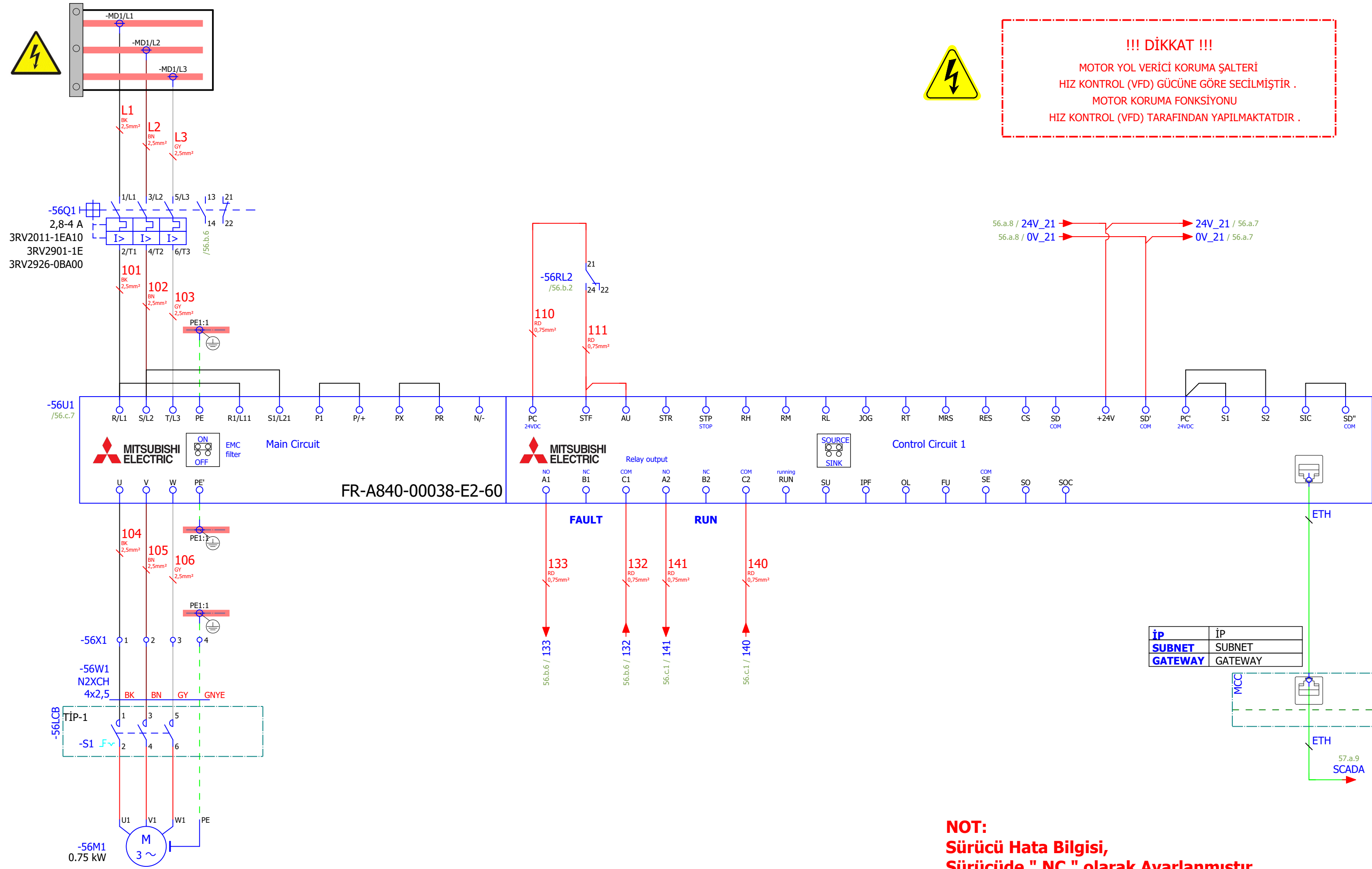

56.a.8 / 24V\_21 → 24V\_21 / 56.a.7  
56.a.8 / 0V\_21 → 0V\_21 / 56.a.7

İP	İP
SUBNET	SUBNET
GATEWAY	GATEWAY

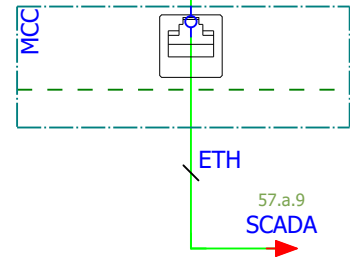

**NOT:**  
Sürücü Hata Bilgisi,  
Sürücüde " NC " olarak Ayarlanmıştır...

Cizen (Drawing)	Kontrol (Control)		Kontrol (Control)		Tag Number	Lokasyon	Sayfa açıklaması (Page description)	Proje adı (Project name)	=
Necip SERT Proje Tasarım	Ufuk GÜLÇEN Proje Sorumlusu		Önder KURT Proje Sorumlusu		ESTR-MLS-DRY2-MSP015-XM2	MCC-21.1	Manyetik Permrol-2-2	Esan Eczacıbaşı Milas ÜYS YENİ KURUTMA	
								Next page:	56.b
								Previous page:	55.c

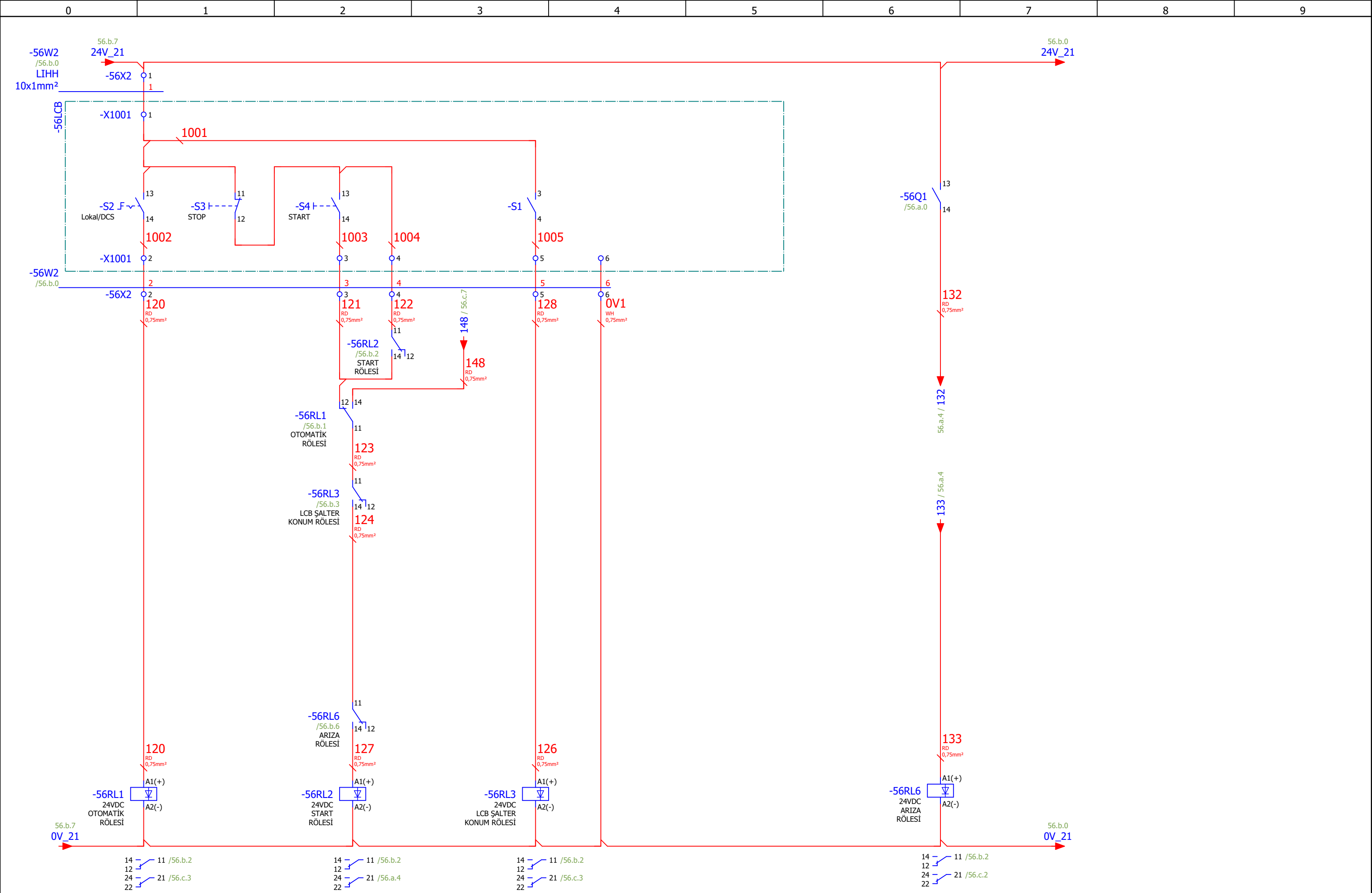

56.a

Page: 56.b

Çizen (Drawing)	Kontrol (Control)	USIA	Kontrol (Control)	Tag Number	Lokasyon	Sayfa açıklaması (Page description)	Proje adı (Project name)	=
Necip SERT Proje Tasarım	Ufuk GÜLÇEN Proje Sorumlusu		Önder KURT Proje Sorumlusu	ESTR-MLS-DRY2-MSP015-XM2	MCC-21.1	Manyetik Permrol-2-2	Esan Eczacıbaşı Milas ÜY YENİ KURUTMA	+
								MCC
								Next page: 56.c
								Previous page: 56.a





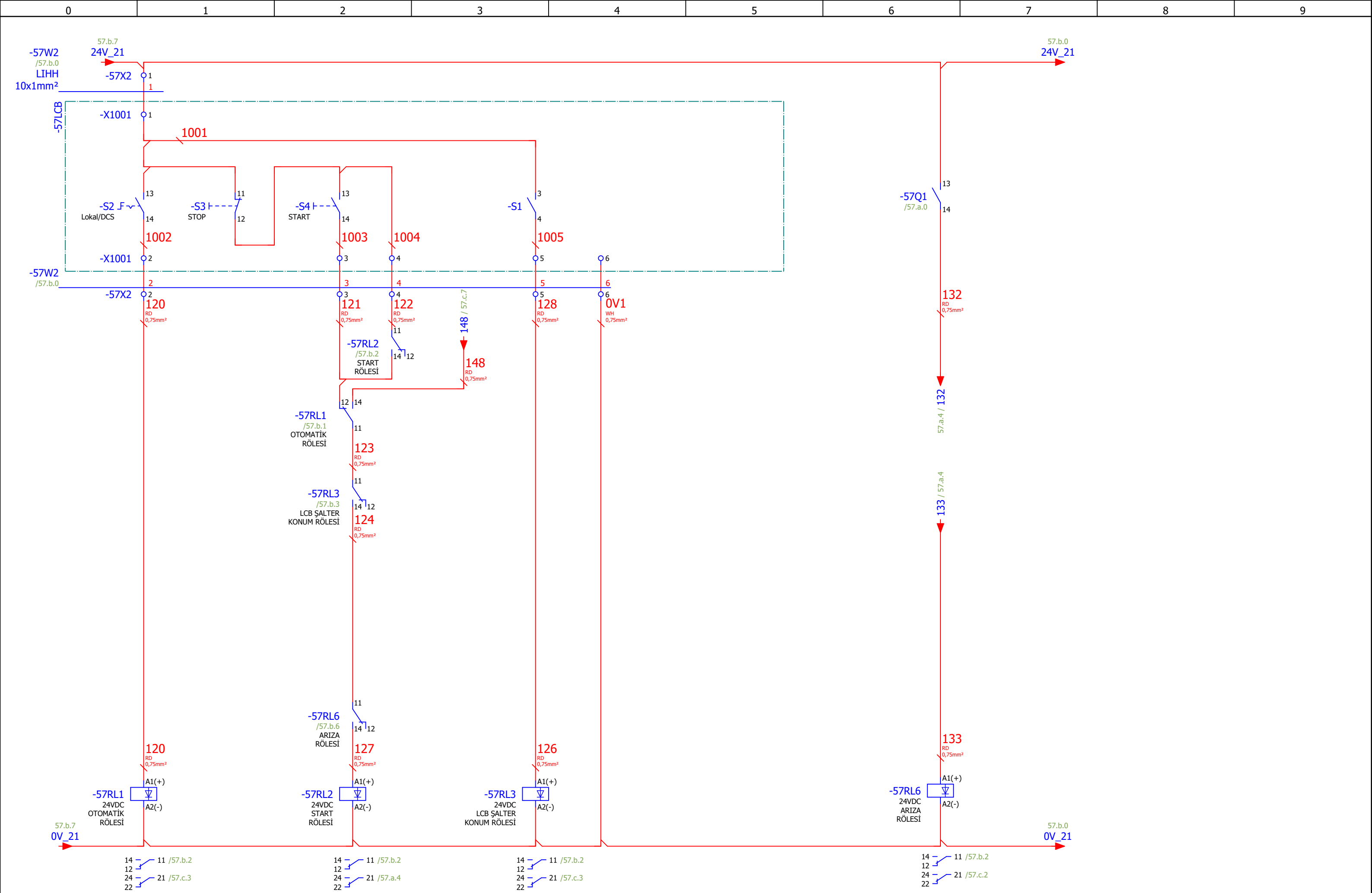

57.a

Page: 57.b

Çizen (Drawing)	Kontrol (Control)	US	Kontrol (Control)	esan	Tag Number	Lokasyon	Sayfa açıklaması (Page description)	Proje adı (Project name)
Necip SERT Proje Tasarım	Ufuk GÜLÇEN Proje Sorumlusu		Önder KURT Proje Sorumlusu		ESTR-MLS-DRY2-MSP015-XM3	MCC-21.2	Manyetik Permrol-2-3	Esan Eczacıbaşı Milas ÜYİ YENİ KURUTMA
=								
+								
Next page: 57.c								
Previous page: 57.a								



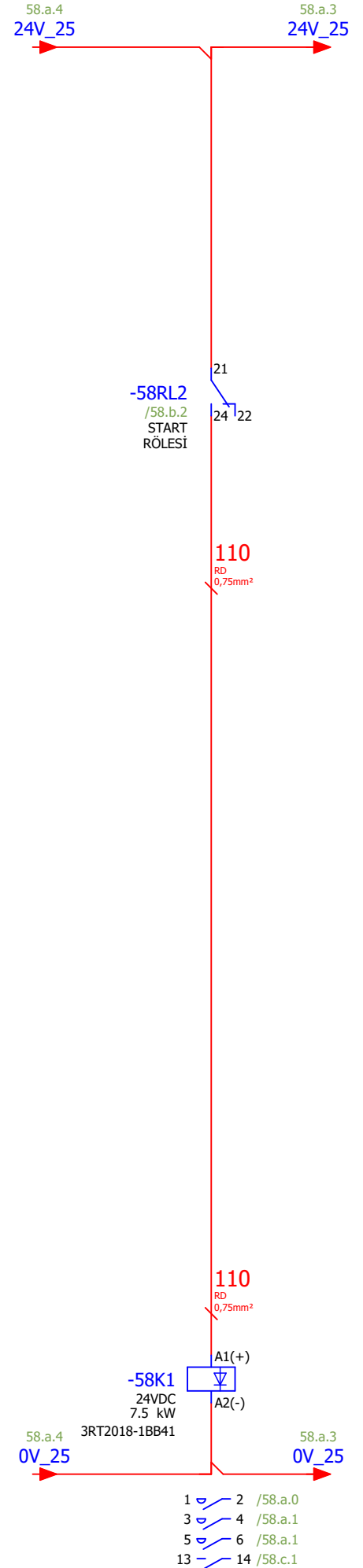
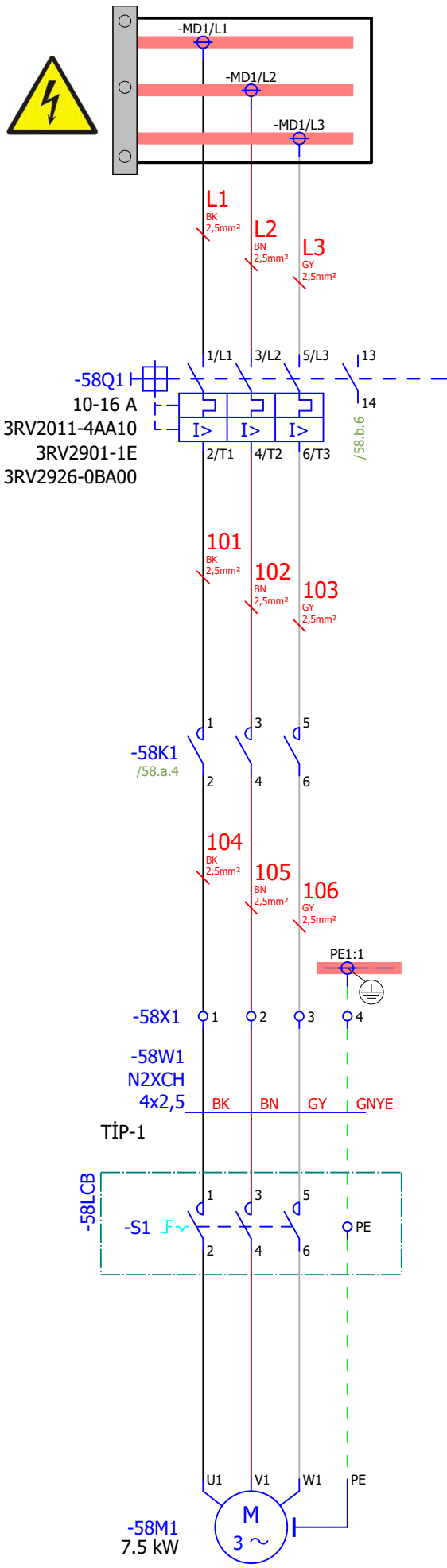

57.c

Page: 58.a

Çizen (Drawing)	Kontrol (Control)	USIA	Kontrol (Control)	esana	Tag Number	Lokasyon	Sayfa açıklaması (Page description)	Proje adı (Project name)	=
Necip SERT Proje Tasarım	Ufuk GÜLÇEN Proje Sorumlusu		Önder KURT Proje Sorumlusu		YEDEK	MCC-25.2	YEDEK	Esan Eczacıbaşı Milas ÜYS YENİ KURUTMA	MCC
									Next page: 58.b
									Previous page: 57.c



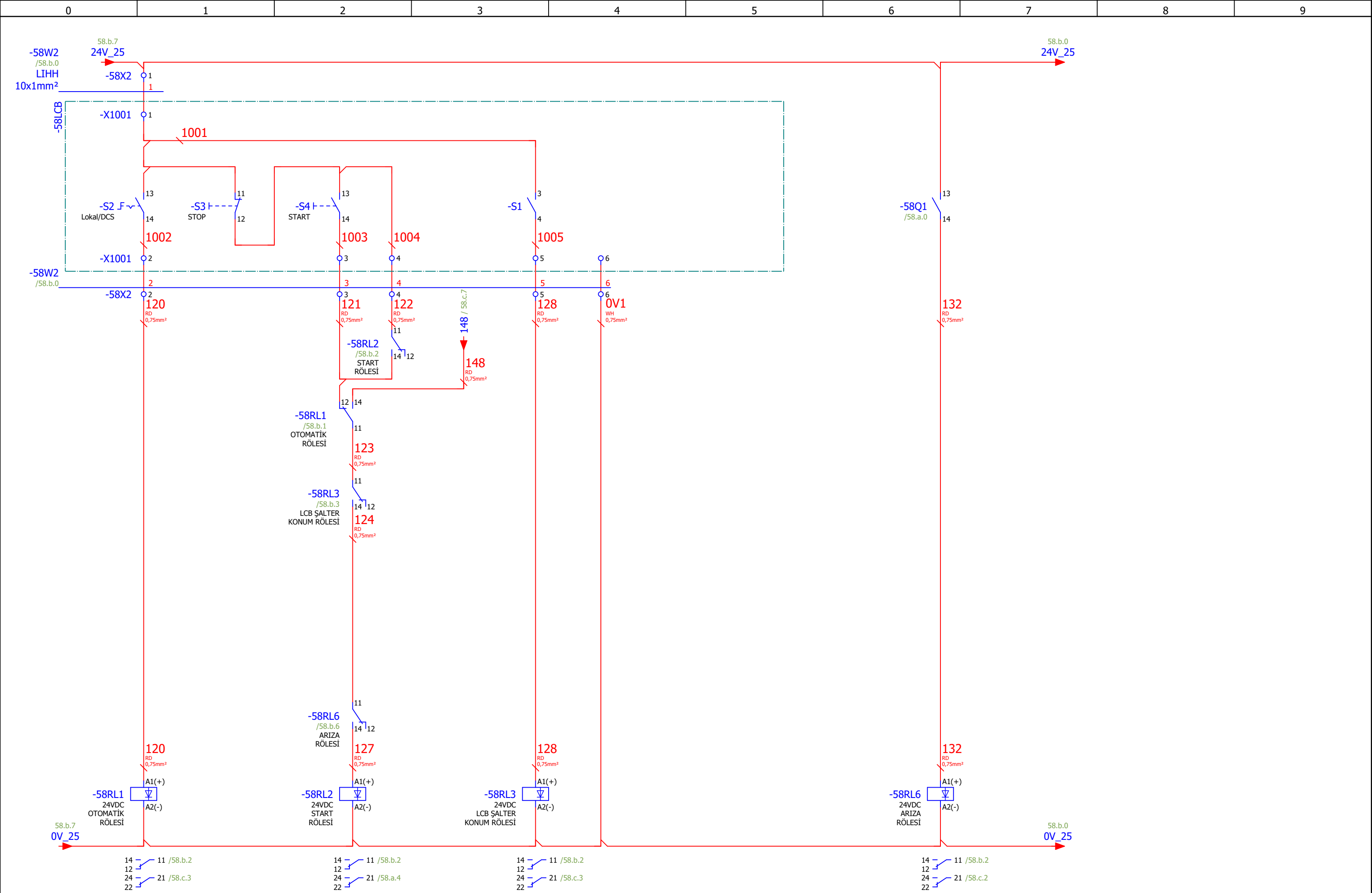

Çizen (Drawing)	Kontrol (Control)	USIA	Kontrol (Control)	Tag Number	Lokasyon	Sayfa açıklaması (Page description)	Proje adı (Project name)
Necip SERT Proje Tasarım	Ufuk GÜLÇEN Proje Sorumlusu		Önder KURT Proje Sorumlusu	YEDEK	MCC-25.2	YEDEK	Esan Eczacıbaşı Milas ÜYS YENİ KURUTMA
=							
+							
Next page: 58.c							
Previous page: 58.a							

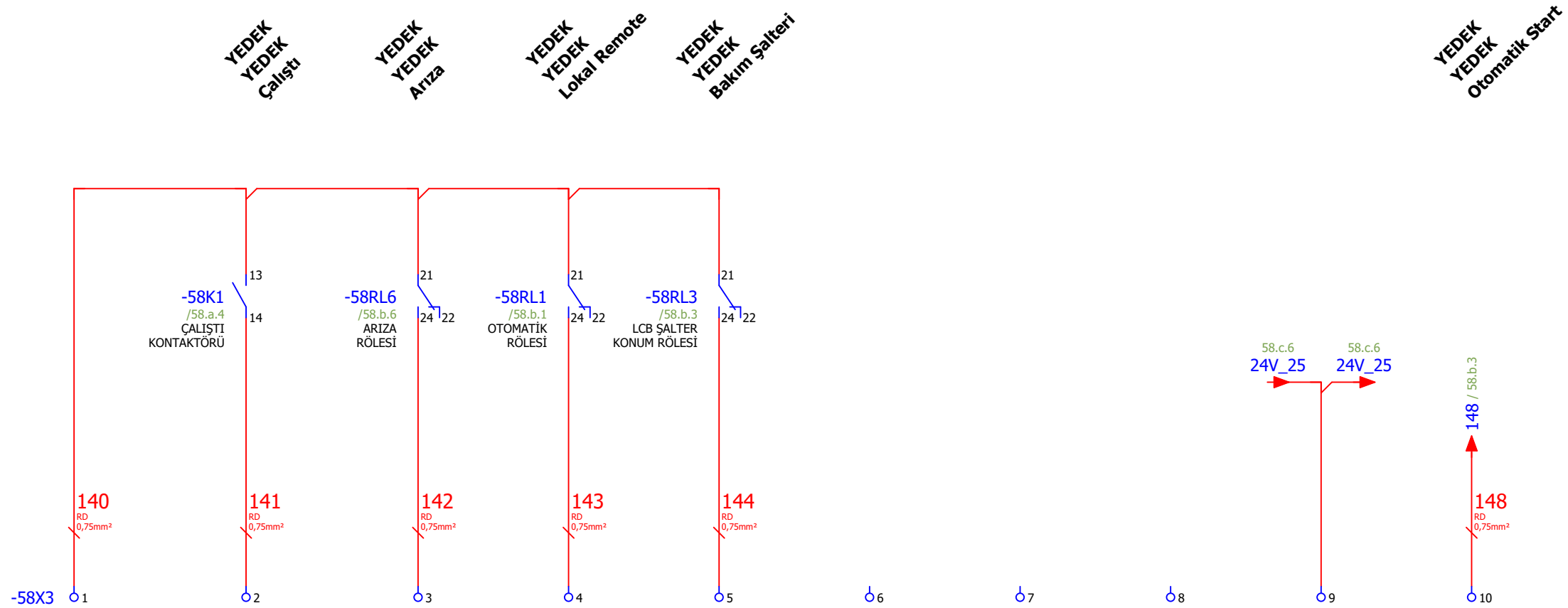

Çizen (Drawing)	Kontrol (Control)	USIA Unique Software at Applications an EPC company	Kontrol (Control)	esan	Tag Number	Lokasyon	Sayfa açıklaması (Page description)	Proje adı (Project name)	=
Necip SERT Proje Tasarım	Ufuk GÜLÇEN Proje Sorumlusu		Önder KURT Proje Sorumlusu		YEDEK	MCC-25.2	YEDEK	Esan Eczacıbaşı Milas ÜYS YENİ KURUTMA	+ MCC

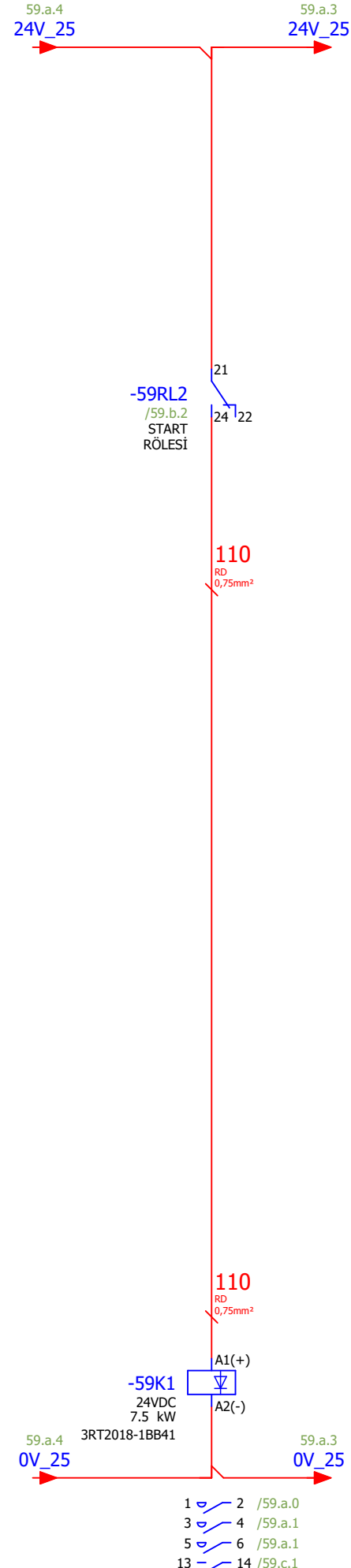
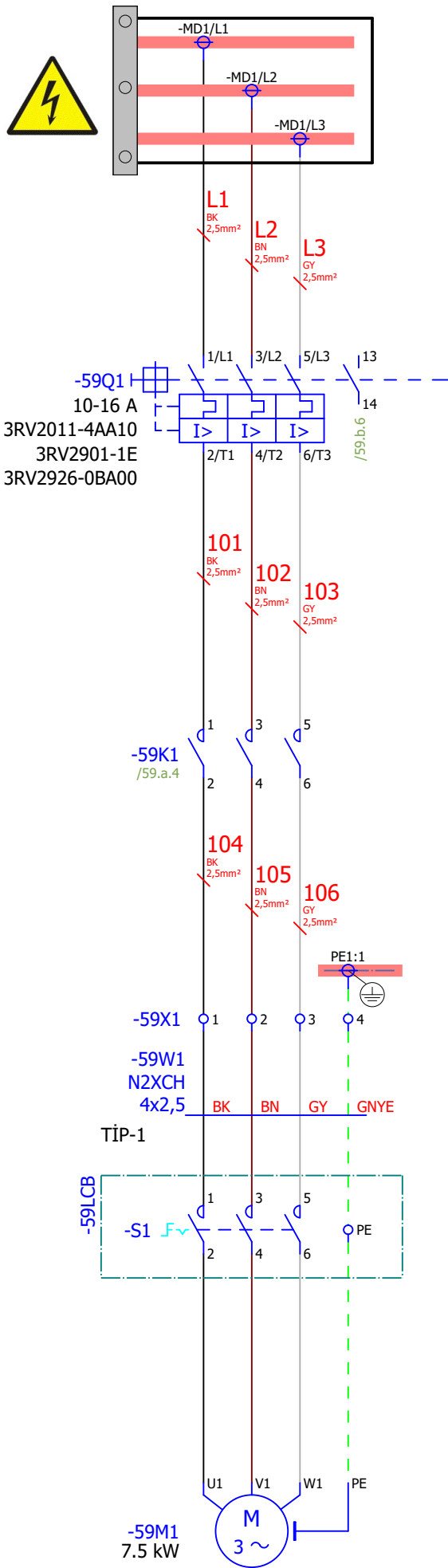

Çizen (Drawing)	Kontrol (Control)
Necip SERT Proje Tasarım	Ufuk GÜLÇEN Proje Sorumlusu



Kontrol (Control)
Önder KURT Proje Sorumlusu



Tag Number
YEDEK

Lokasyon
MCC-25.3

Sayfa açıklaması (Page description)
YEDEK

Proje adı (Project name)
Esan Eczacıbaşı Milas ÜYS YENİ KURUTMA

=	
+	MCC
Next page:	59.b
Previous page:	58.c

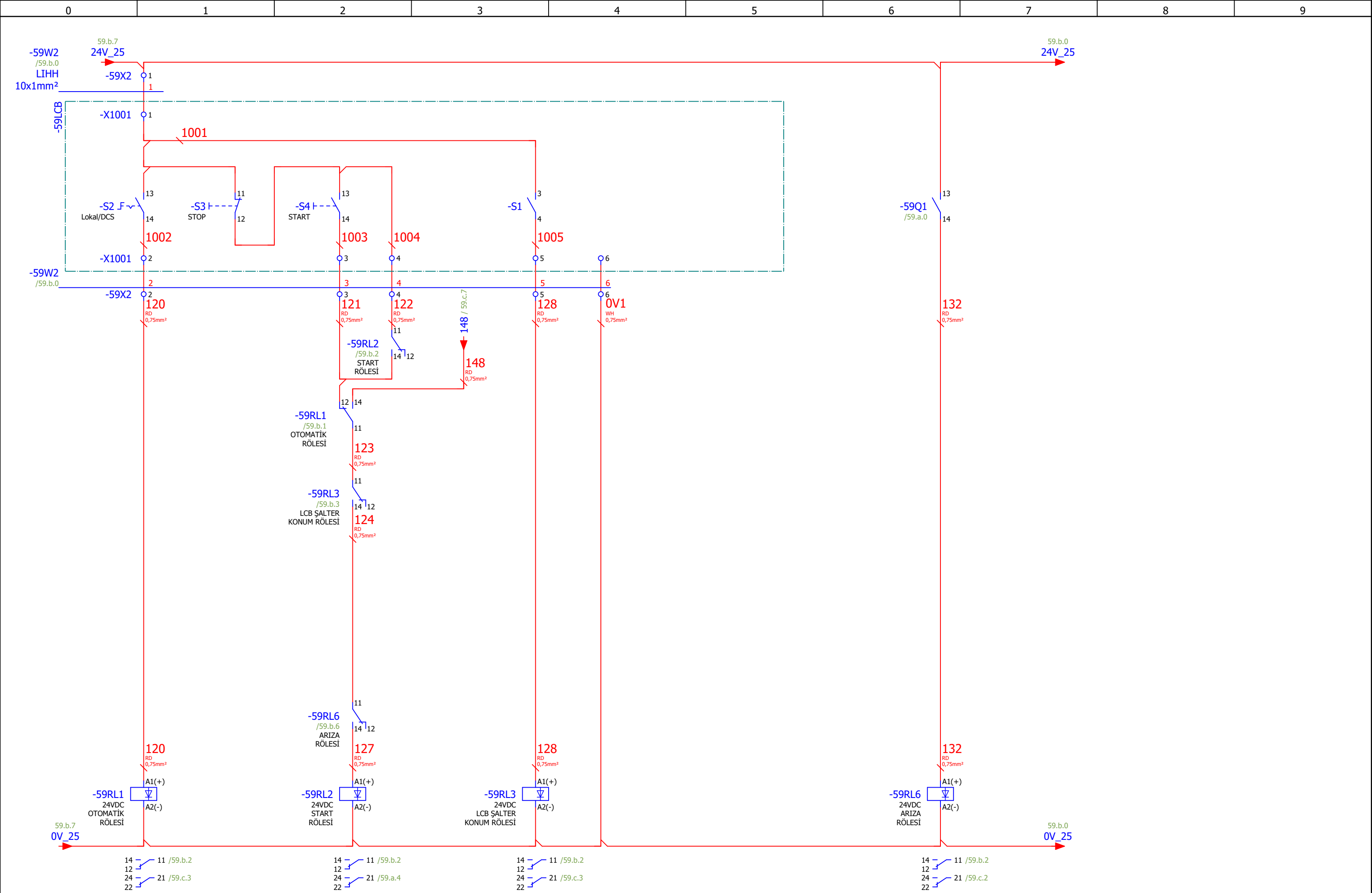

Çizen (Drawing)	Kontrol (Control)	USIA	Kontrol (Control)	Tag Number	Lokasyon	Sayfa açıklaması (Page description)	Proje adı (Project name)
Necip SERT Proje Tasarım	Ufuk GÜLÇEN Proje Sorumlusu		Önder KURT Proje Sorumlusu	YEDEK	MCC-25.3	YEDEK	Esan Eczacıbaşı Milas ÜYS YENİ KURUTMA
=							
+							
Next page: 59.c							
Previous page: 59.a							



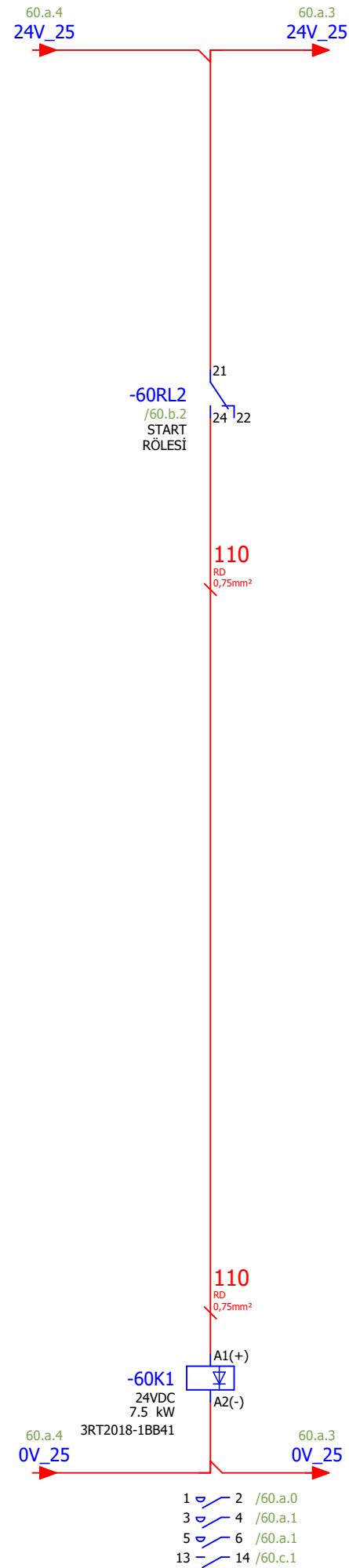
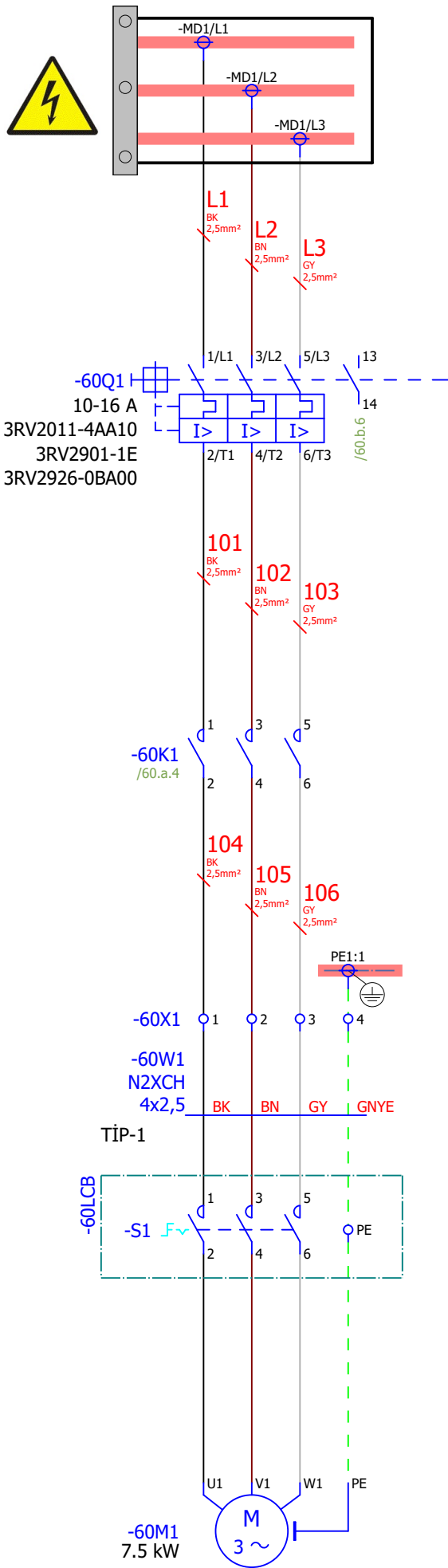

Çizen (Drawing)	Kontrol (Control)	USIA	Kontrol (Control)	esan	Tag Number	Lokasyon	Sayfa açıklaması (Page description)	Proje adı (Project name)	=
Necip SERT Proje Tasarım	Ufuk GÜLÇEN Proje Sorumlusu		Önder KURT Proje Sorumlusu		YEDEK	MCC-25.4	YEDEK	Esan Eczacıbaşı Milas ÜYS YENİ KURUTMA	+ MCC
									Next page: 60.b
									Previous page: 59.c

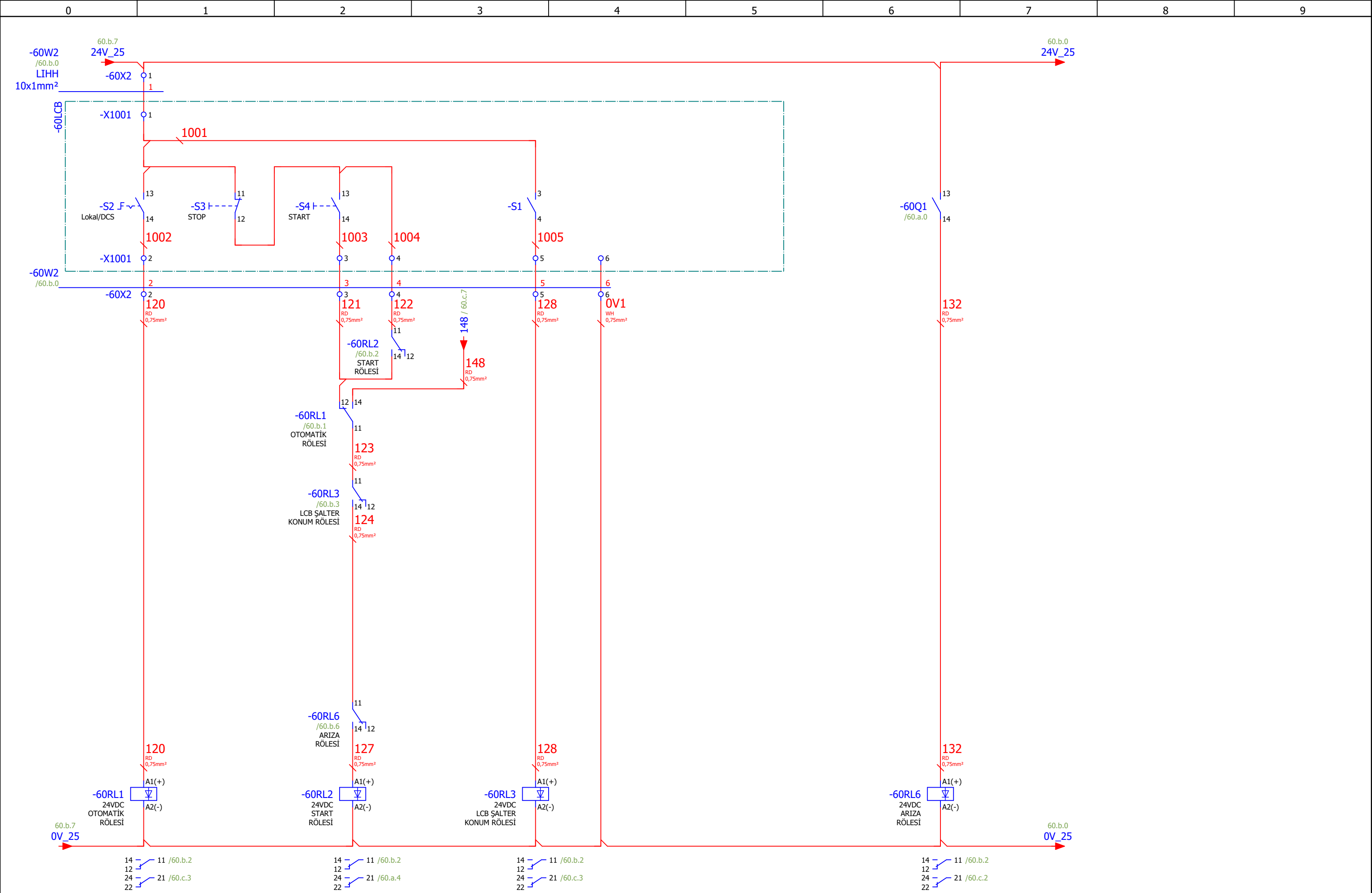

60.a

Page: 60.b

Çizen (Drawing)	Kontrol (Control)	USİA Unique Software at Applications an EPC company	Kontrol (Control)	esan	Tag Number	Lokasyon	Sayfa açıklaması (Page description)	Proje adı (Project name)	=
Necip SERT Proje Tasarım	Ufuk GÜLÇEN Proje Sorumlusu		Önder KURT Proje Sorumlusu		YEDEK	MCC-25.4	YEDEK	Esan Eczacıbaşı Milas ÜYS YENİ KURUTMA	+ MCC

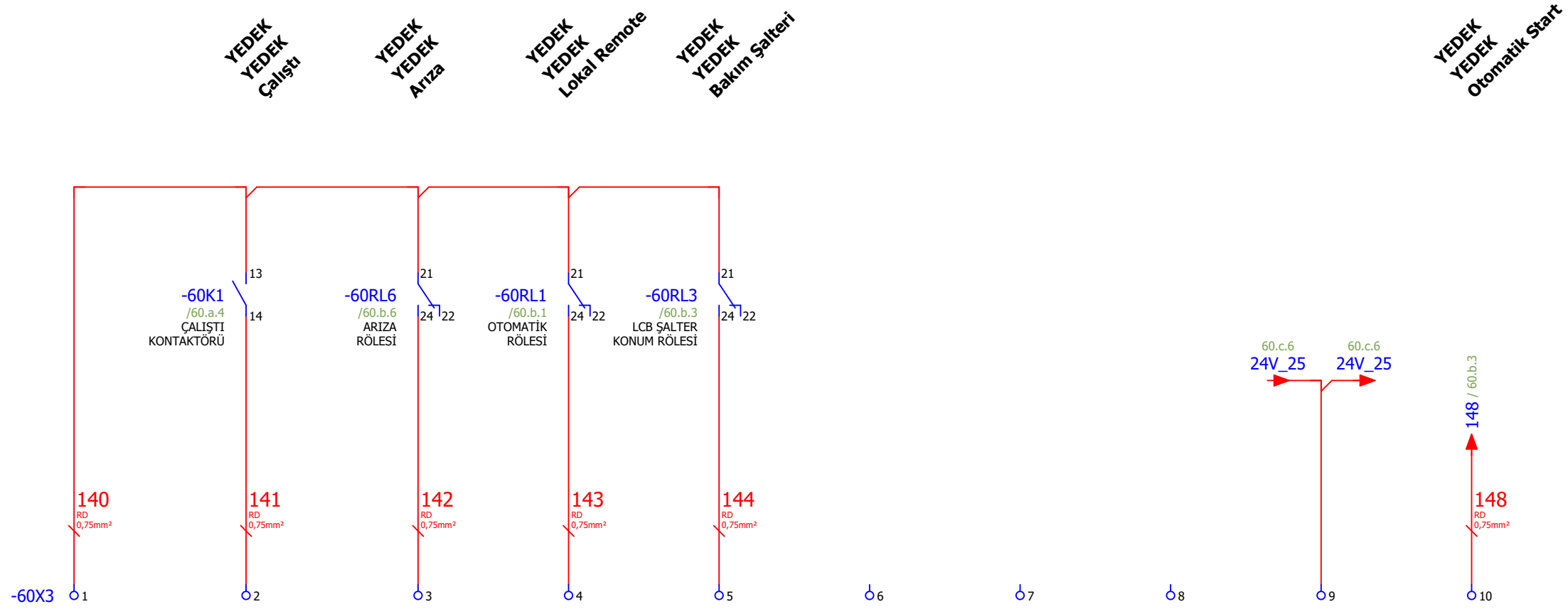

Çizen (Drawing)	Kontrol (Control)	USIA Unique Software at Applications an EPC company	Kontrol (Control)	esan	Tag Number	Lokasyon	Sayfa açıklaması (Page description)	Proje adı (Project name)	=
Necip SERT Proje Tasarım	Ufuk GÜLÇEN Proje Sorumlusu		Önder KURT Proje Sorumlusu		YEDEK	MCC-25.4	YEDEK	Esan Eczacıbaşı Milas ÜYS YENİ KURUTMA	+ MCC



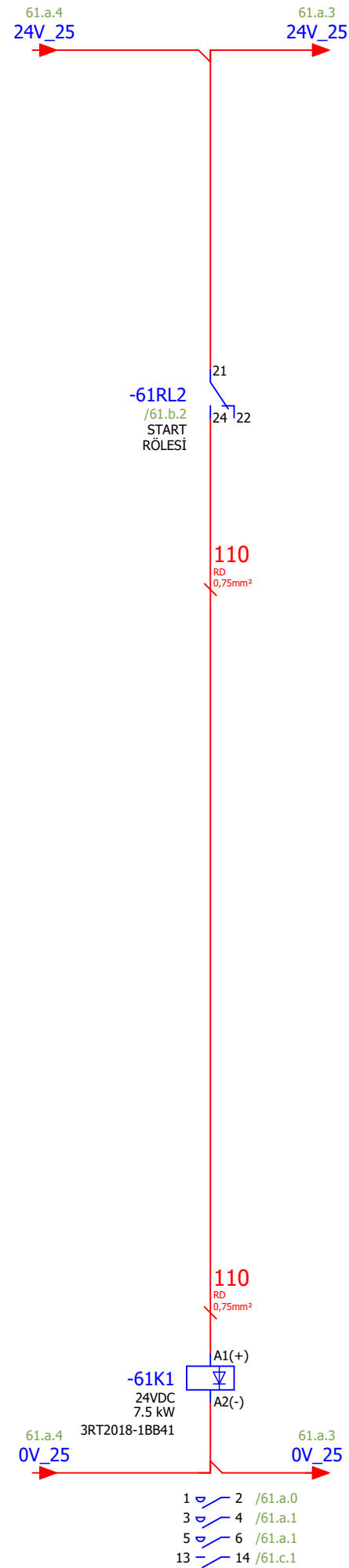
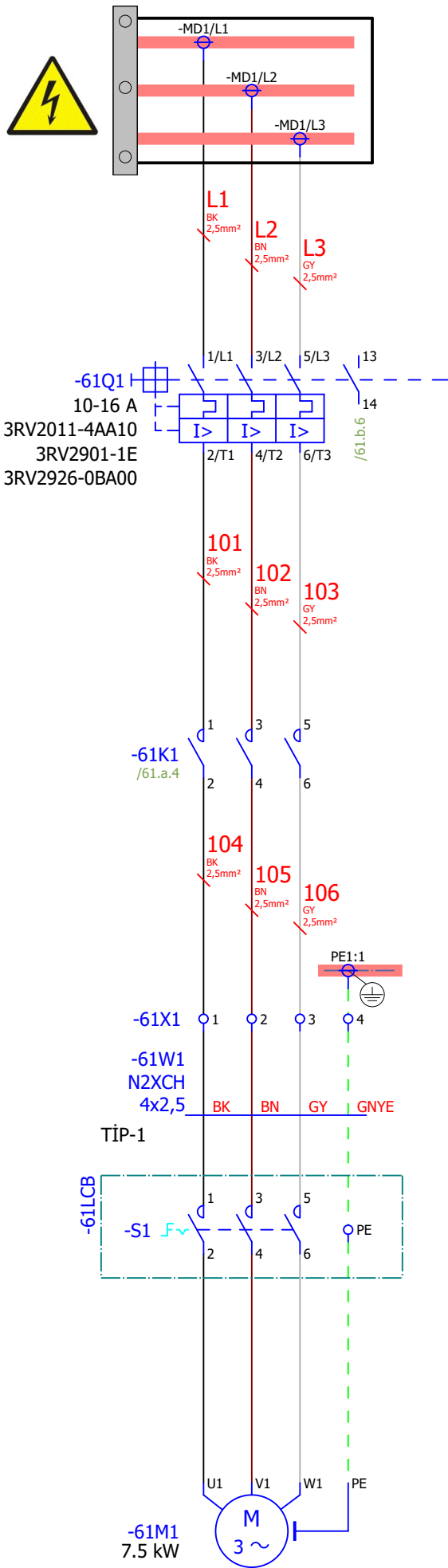

Çizen (Drawing)	Kontrol (Control)	USIA	Kontrol (Control)	esan	Tag Number	Lokasyon	Sayfa açıklaması (Page description)	Proje adı (Project name)	=
Necip SERT Proje Tasarım	Ufuk GÜLÇEN Proje Sorumlusu		Önder KURT Proje Sorumlusu		YEDEK	MCC-25.5	YEDEK	Esan Eczacıbaşı Milas ÜYS YENİ KURUTMA	+ MCC
									Next page: 61.b
									Previous page: 60.c

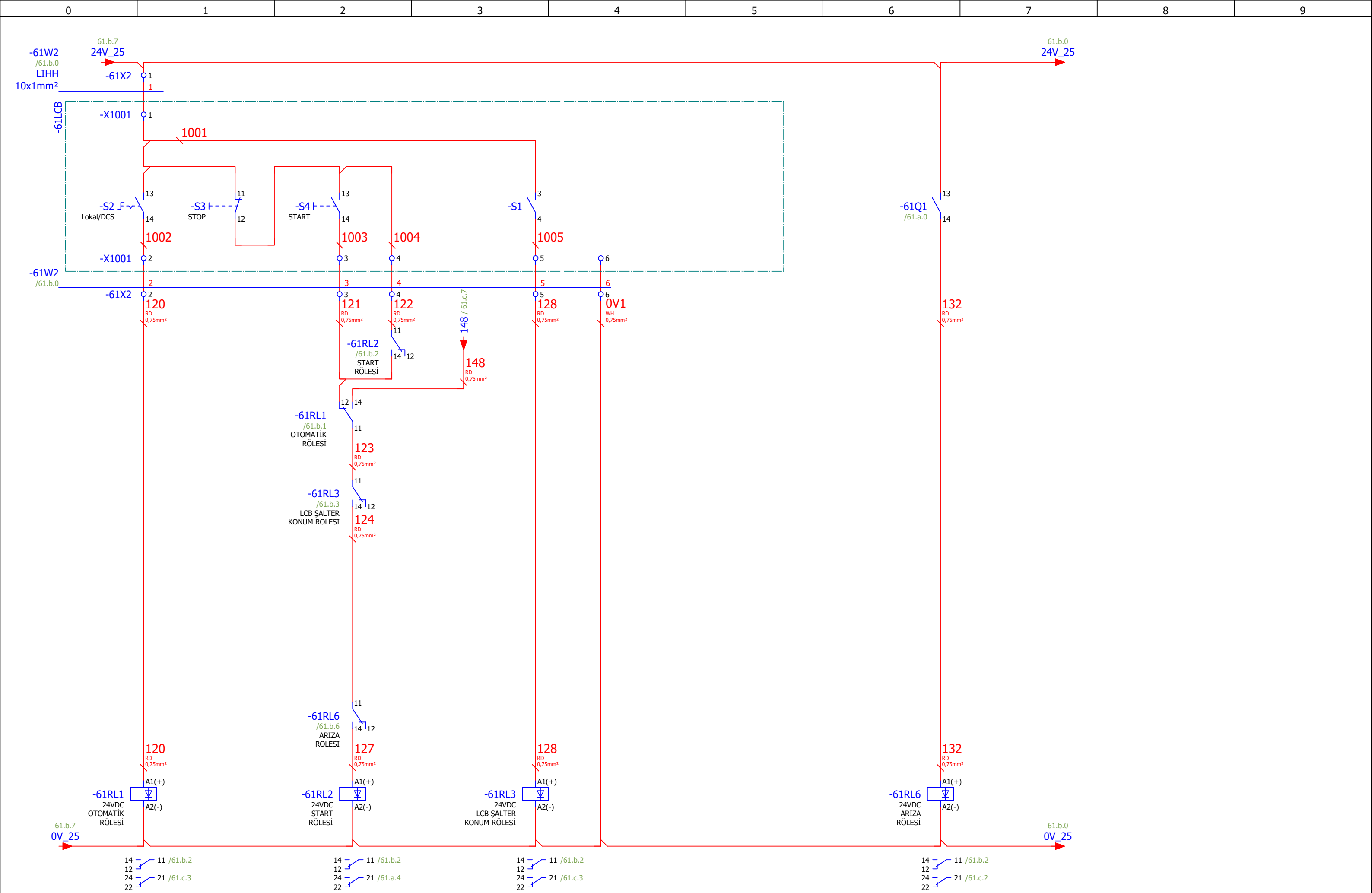

61.a

Page: 61.b

Çizen (Drawing)	Kontrol (Control)	USIA	Kontrol (Control)	Tag Number	Lokasyon	Sayfa açıklaması (Page description)	Proje adı (Project name)
Necip SERT Proje Tasarım	Ufuk GÜLÇEN Proje Sorumlusu		Önder KURT Proje Sorumlusu	YEDEK	MCC-25.5	YEDEK	Esan Eczacıbaşı Milas ÜYS YENİ KURUTMA
=							
+							
Next page: 61.c							
Previous page: 61.a							



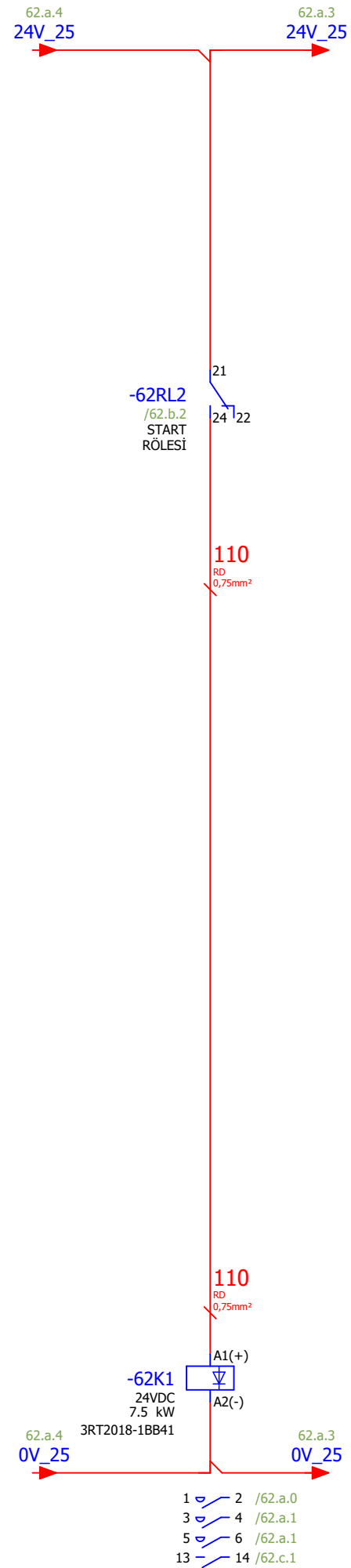
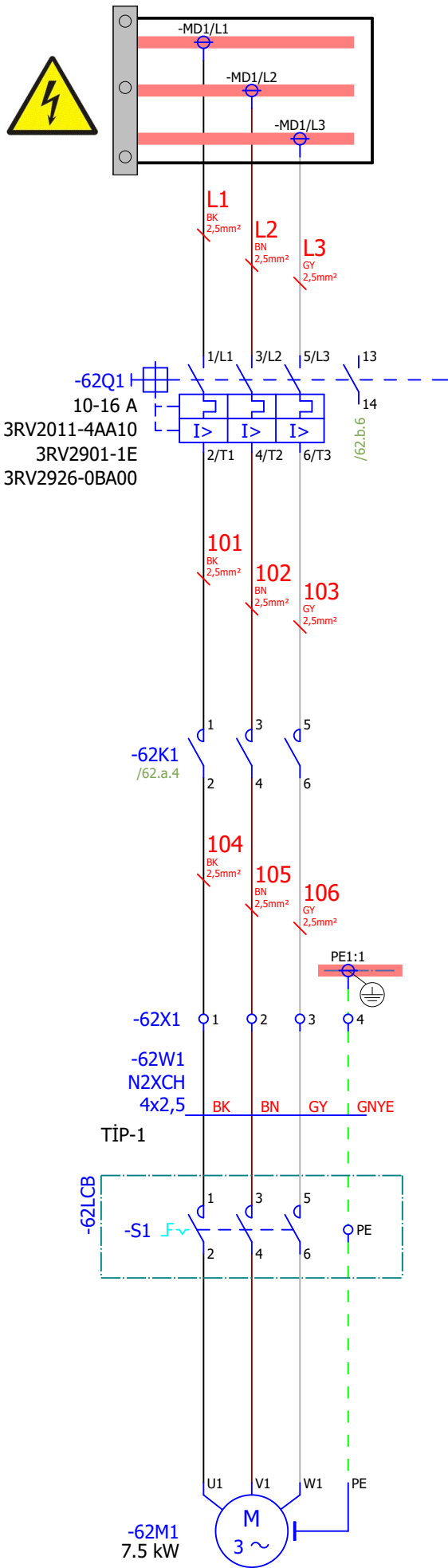

Çizen (Drawing)	Kontrol (Control)	USIA	Kontrol (Control)	esan	Tag Number	Lokasyon	Sayfa açıklaması (Page description)	Proje adı (Project name)	=
Necip SERT Proje Tasarım	Ufuk GÜLÇEN Proje Sorumlusu		Önder KURT Proje Sorumlusu		YEDEK	MCC-25.6	YEDEK	Esan Eczacıbaşı Milas ÜYS YENİ KURUTMA	+ MCC
									Next page: 62.b
									Previous page: 61.c

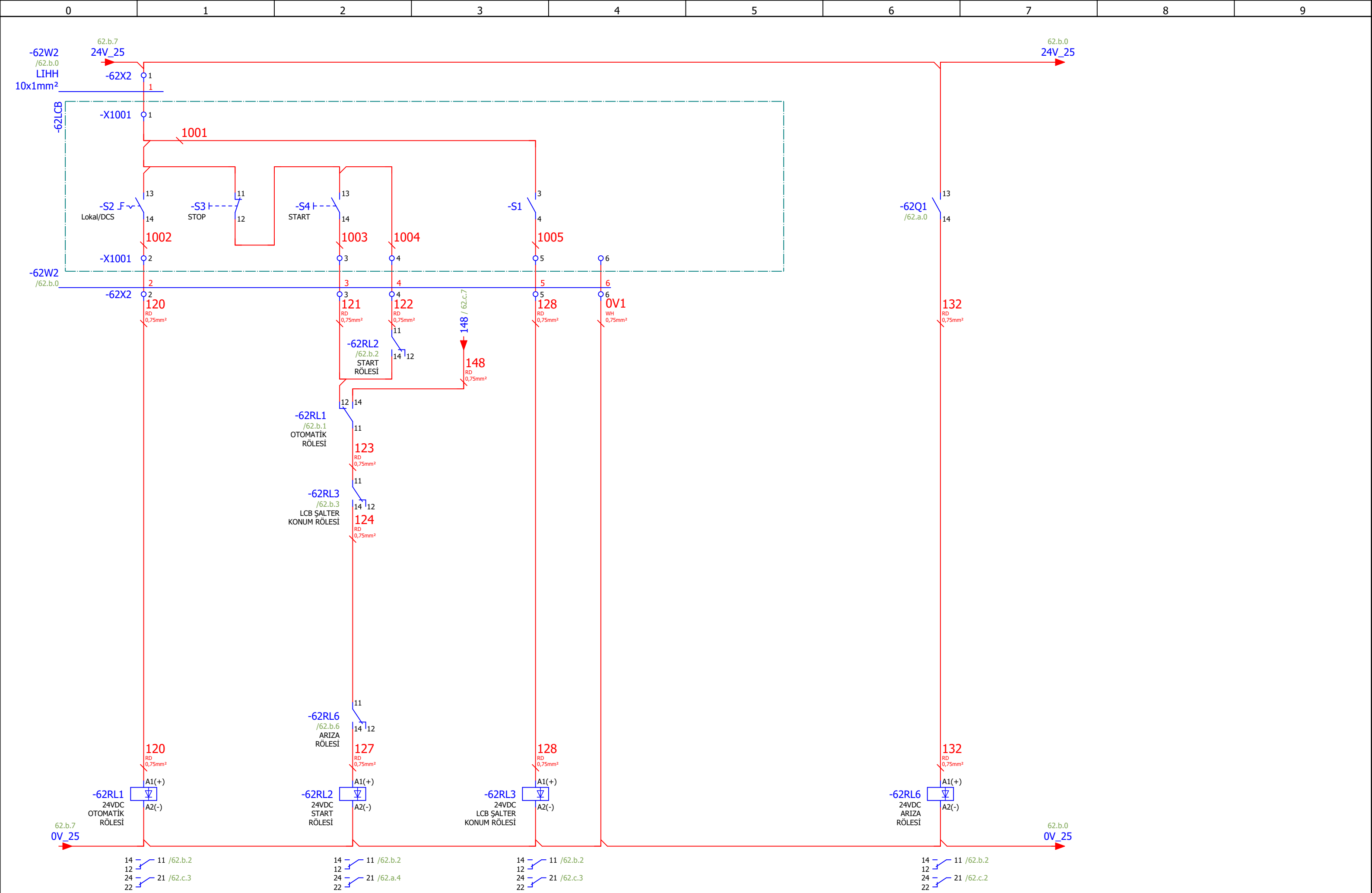

62.a

Page: 62.b

Çizen (Drawing)	Kontrol (Control)	USIA	Kontrol (Control)	es	Tag Number	Lokasyon	Sayfa açıklaması (Page description)	Proje adı (Project name)	=
Necip SERT Proje Tasarım	Ufuk GÜLÇEN Proje Sorumlusu		Önder KURT Proje Sorumlusu		YEDEK	MCC-25.6	YEDEK	Esan Eczacıbaşı Milas ÜYS YENİ KURUTMA	MCC
									Next page: 62.c
									Previous page: 62.a



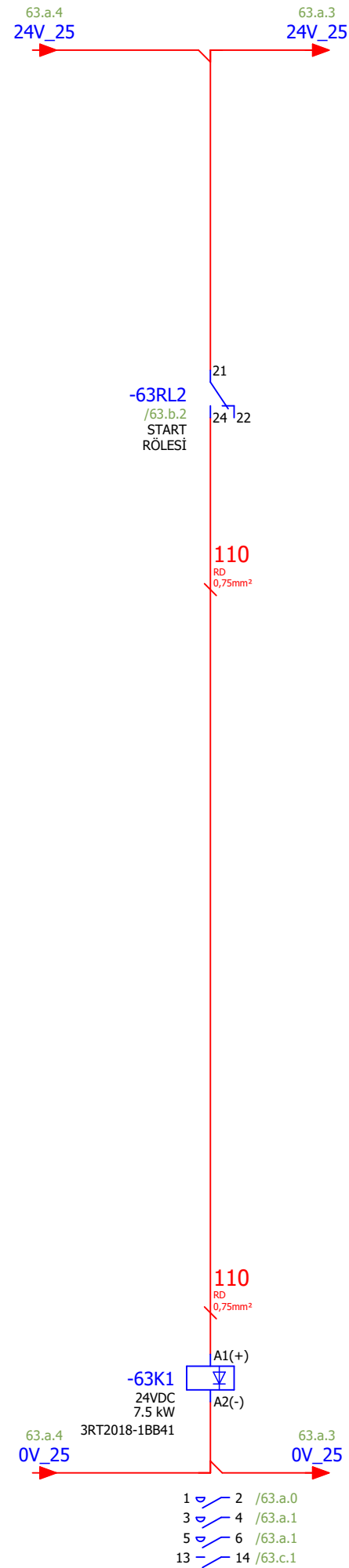
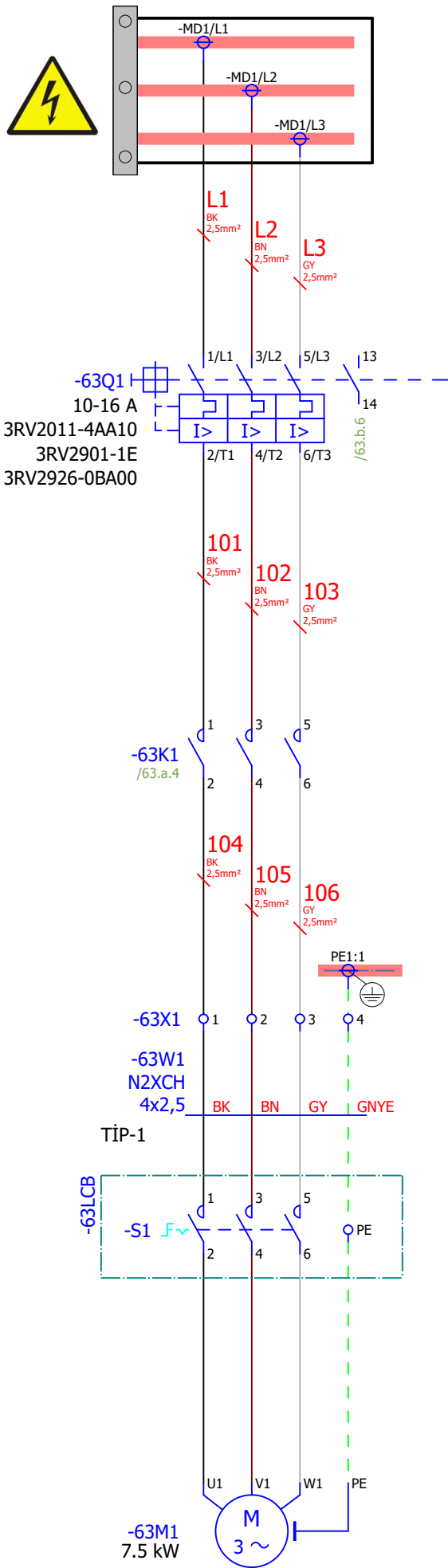

Çizen (Drawing)	Kontrol (Control)	USIA	Kontrol (Control)	esana	Tag Number	Lokasyon	Sayfa açıklaması (Page description)	Proje adı (Project name)	=
Necip SERT Proje Tasarım	Ufuk GÜLÇEN Proje Sorumlusu		Önder KURT Proje Sorumlusu		YEDEK	MCC-25.7	YEDEK	Esan Eczacıbaşı Milas ÜYS YENİ KURUTMA	MCC
									Next page: 63.b
									Previous page: 62.c

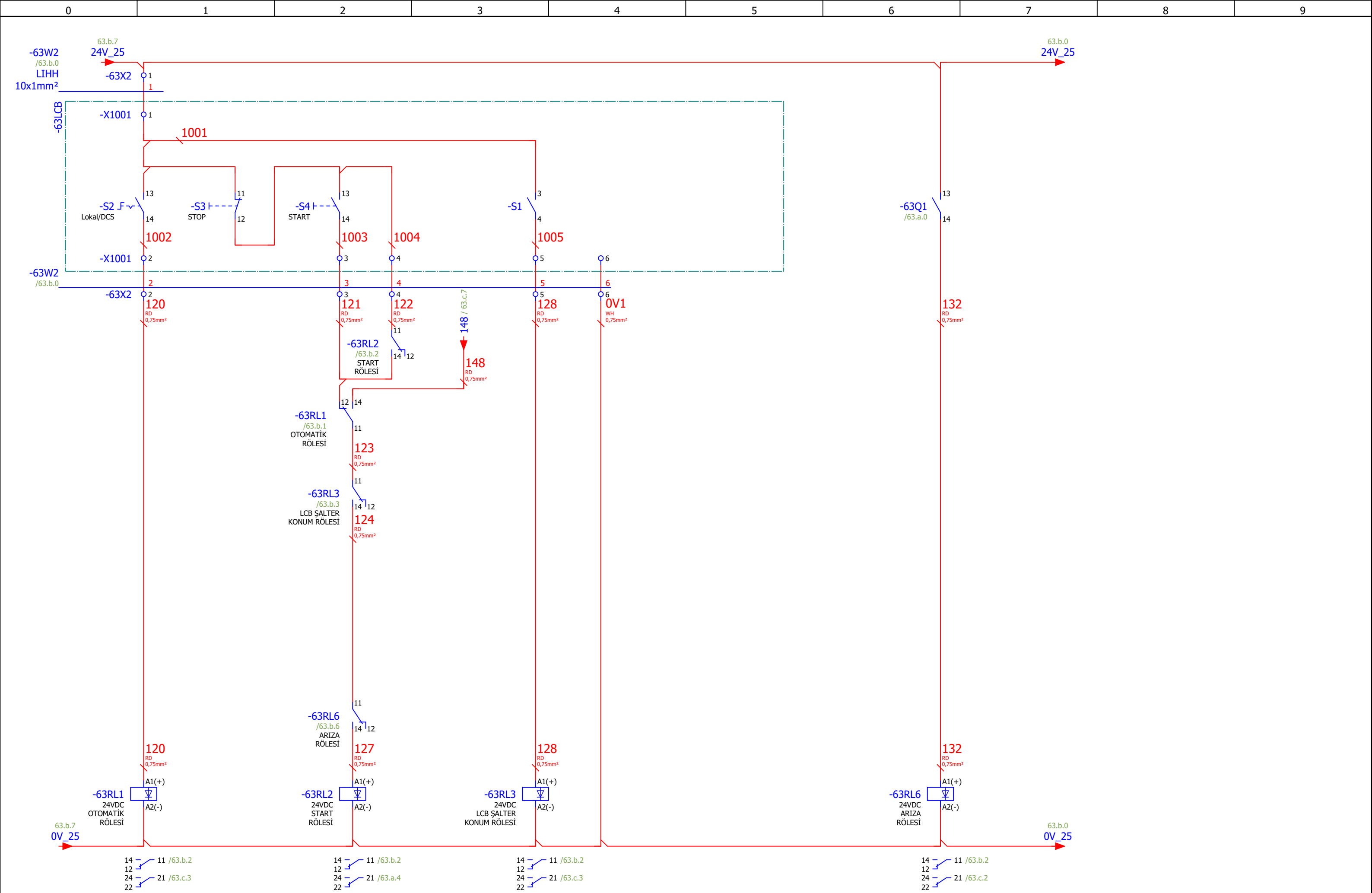

63.a

Page: 63.b

Çizen (Drawing)	Kontrol (Control)	USIA	Kontrol (Control)	Tag Number	Lokasyon	Sayfa açıklaması (Page description)	Proje adı (Project name)	=
Necip SERT Proje Tasarım	Ufuk GÜLÇEN Proje Sorumlusu		Önder KURT Proje Sorumlusu	YEDEK	MCC-25.7	YEDEK	Esan Eczacıbaşı Milas ÜYS YENİ KURUTMA	MCC
								Next page: 63.c
								Previous page: 63.a





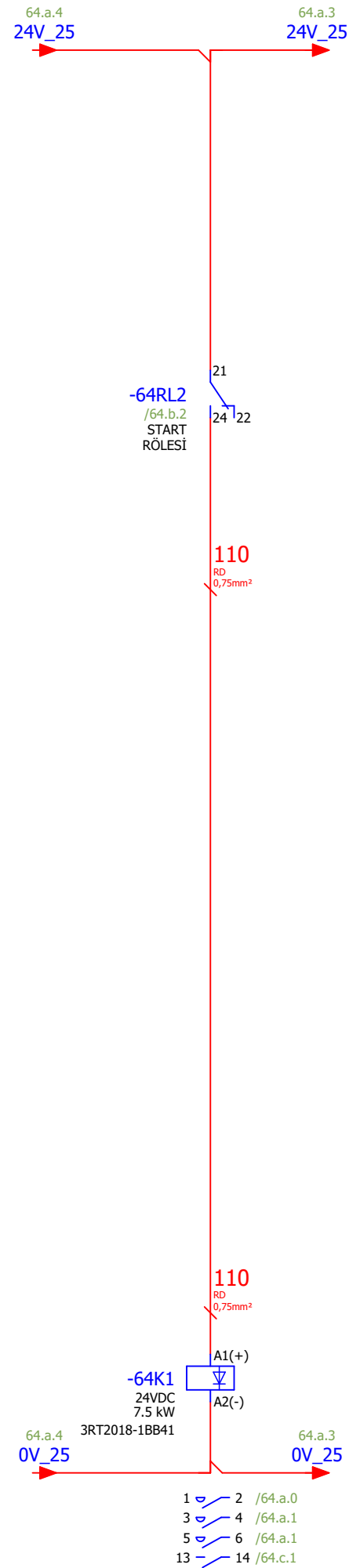
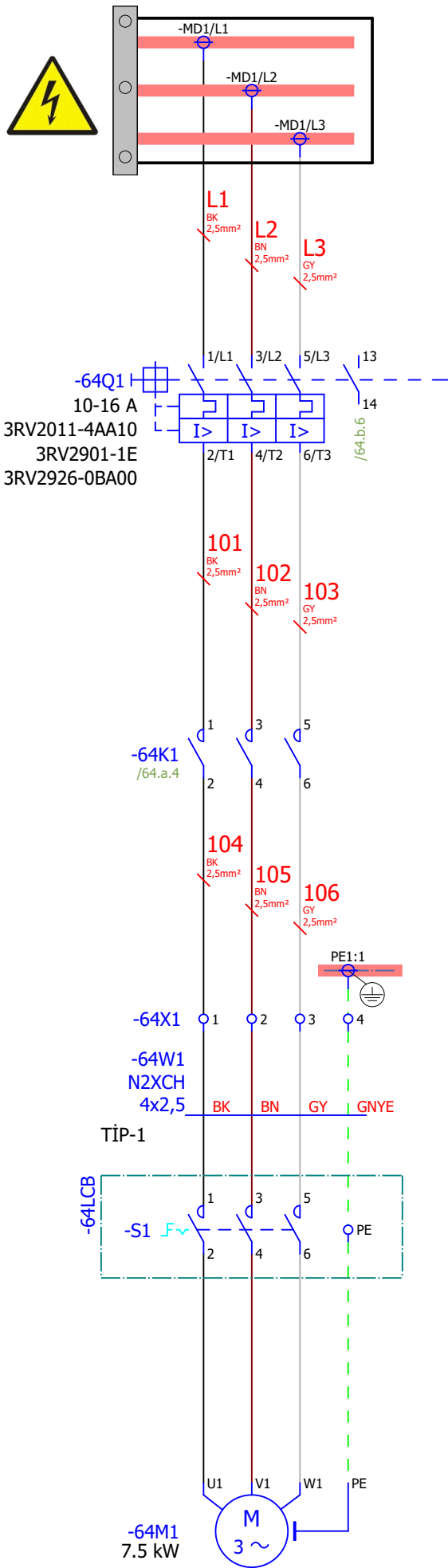

Çizen (Drawing)	Kontrol (Control)	USIA	Kontrol (Control)	esan	Tag Number	Lokasyon	Sayfa açıklaması (Page description)	Proje adı (Project name)	=
Necip SERT Proje Tasarım	Ufuk GÜLÇEN Proje Sorumlusu		Önder KURT Proje Sorumlusu		YEDEK	MCC-25.8	YEDEK	Esan Eczacıbaşı Milas ÜYS YENİ KURUTMA	MCC
									Next page: 64.b
									Previous page: 63.c

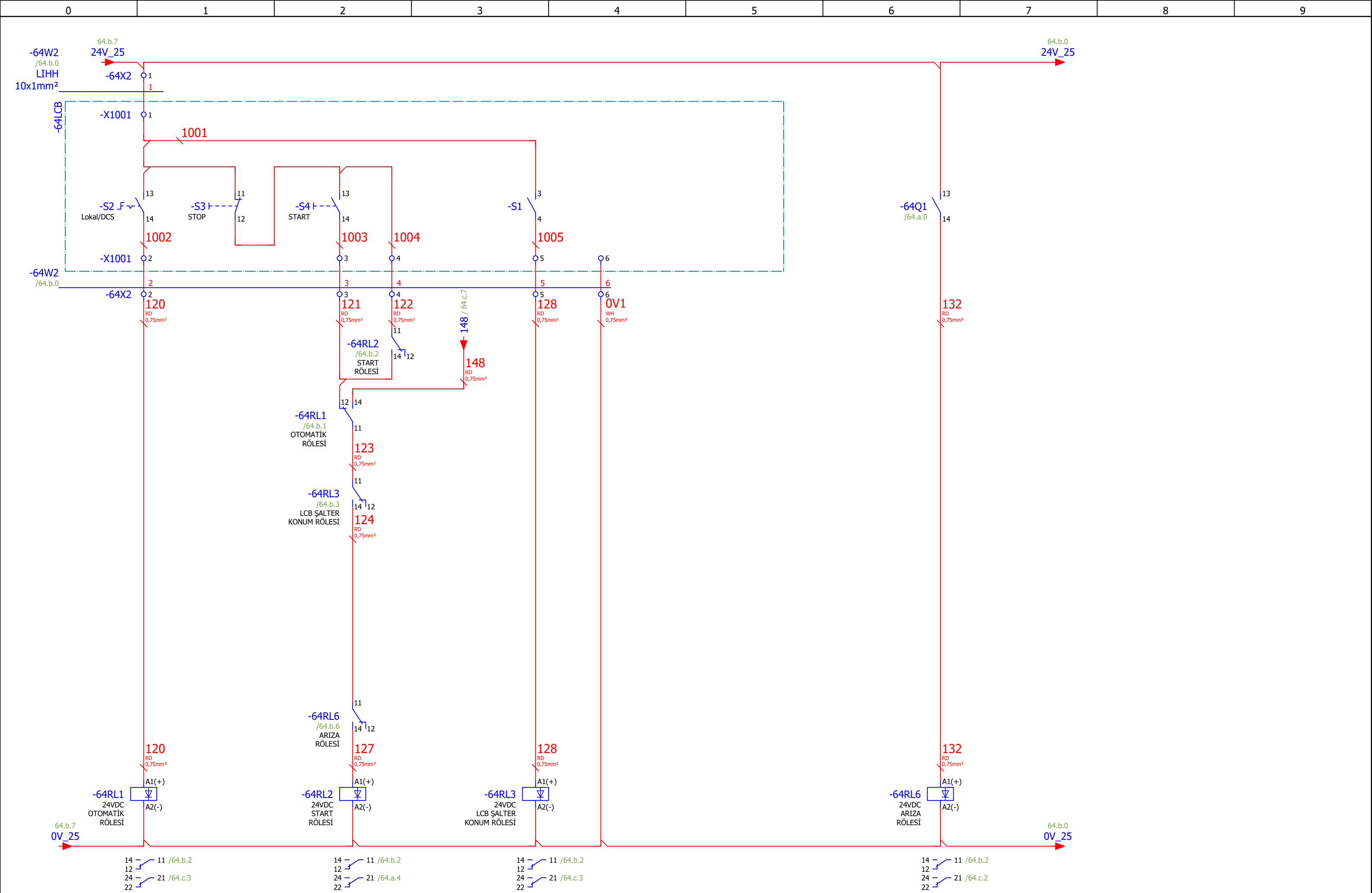

Çizen (Drawing)	Kontrol (Control)	USIA	Kontrol (Control)	Tag Number	Lokasyon	Sayfa açıklaması (Page description)	Proje adı (Project name)	=
Necip SERT Proje Tasarım	Ufuk GÜLÇEN Proje Sorumlusu		Önder KURT Proje Sorumlusu	YEDEK	MCC-25.8	YEDEK	Esan Eczacıbaşı Milas ÜYS YENİ KURUTMA	MCC
								Next page: 64.c
								Previous page: 64.a



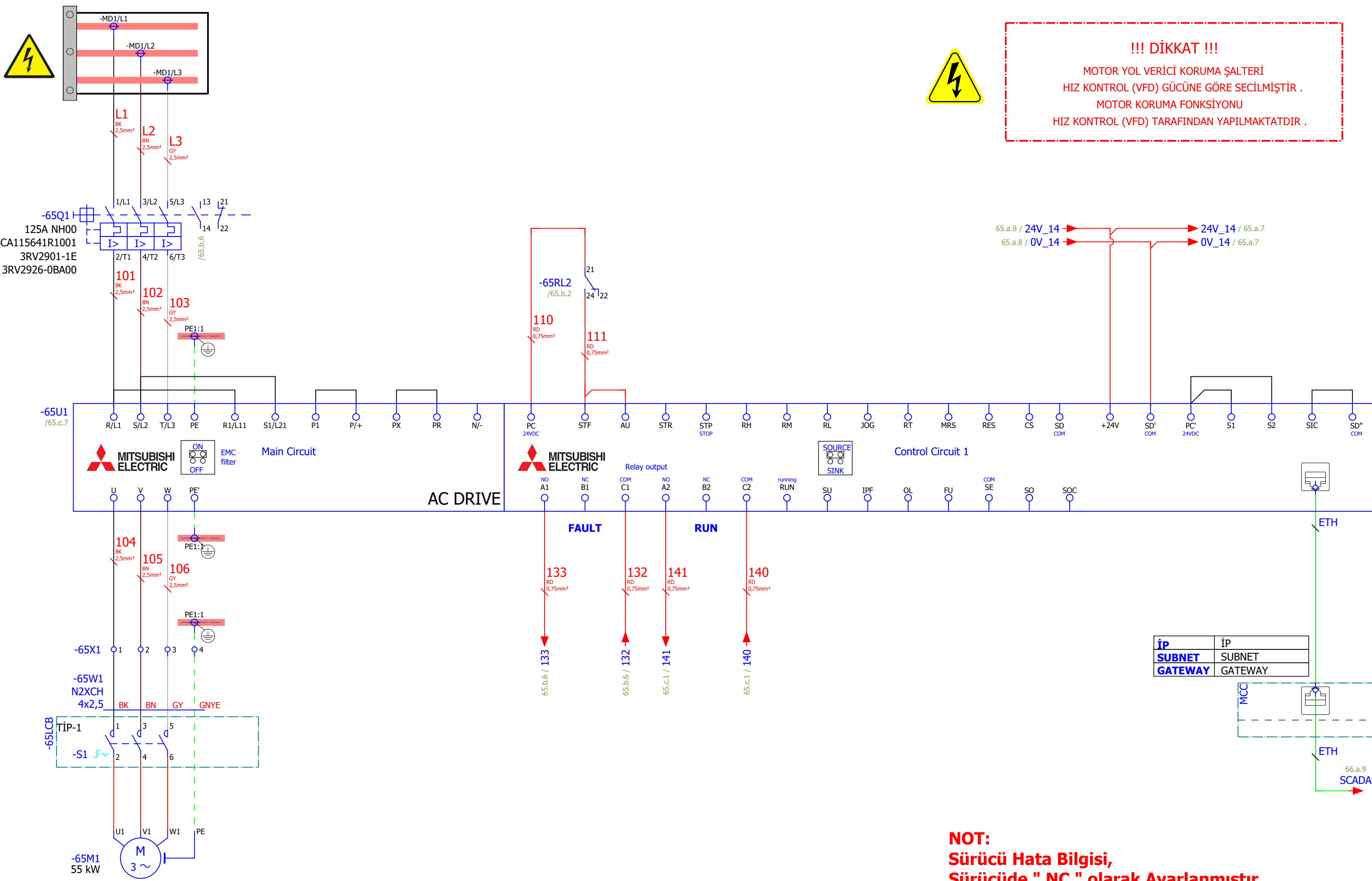

**!!! DİKKAT !!!**  
 MOTOR YOL VERİCİ KORUMA ŞALTERİ  
 HIZ KONTROL (VFD) GÜCÜNE GÖRE SEÇİLMİŞTİR .  
 MOTOR KORUMA FONKSİYONU  
 HIZ KONTROL (VFD) TARAFINDAN YAPILMAKTADIR .

<b>İP</b>	İP
<b>SUBNET</b>	SUBNET
<b>GATEWAY</b>	GATEWAY

**NOT:**  
 Sürücü Hata Bilgisi,  
 Sürücüde " NC " olarak Ayarlanmıştır...

Cizen (Drawing)	Kontrol (Control)		Kontrol (Control)		Tag Number	Lokasyon	Sayfa açıklaması (Page description)	Proje adı (Project name)	=
Necip SERT Proje Tasarım	Ufuk GÜLÇEN Proje Sorumlusu		Önder KURT Proje Sorumlusu		YEDEK	MCC-14	YEDEK	Esan Eczacıbaşı Milas ÜYS YENİ KURUTMA	+
									Next page: 65.b
									Previous page: 64.c

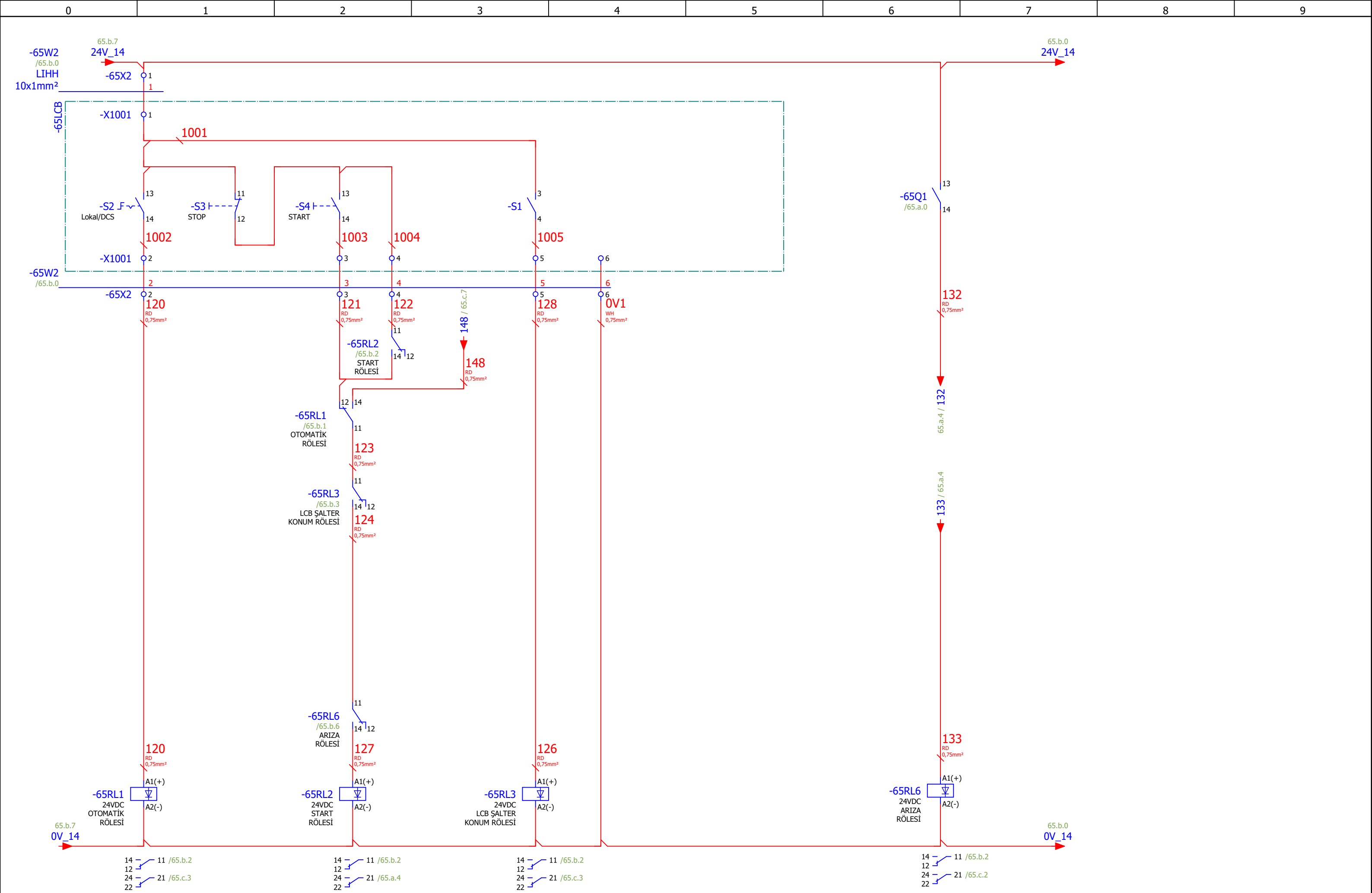



65.a

Page: 65.b

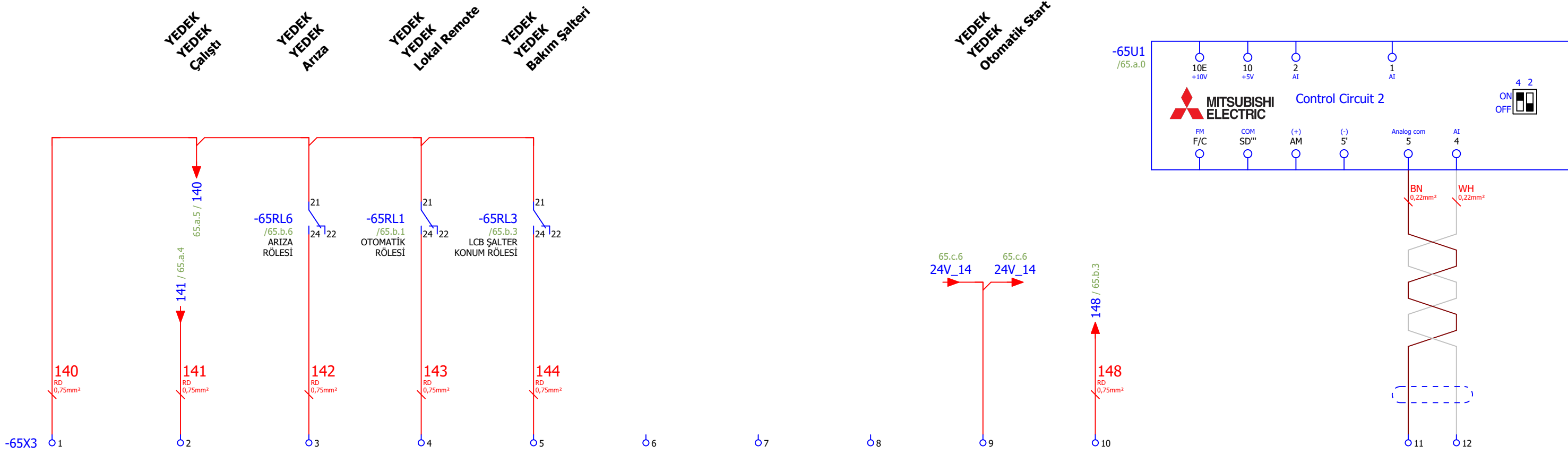
Çizen (Drawing)	Kontrol (Control)	USIA	Kontrol (Control)	Tag Number	Lokasyon	Sayfa açıklaması (Page description)	Proje adı (Project name)	=
Necip SERT Proje Tasarım	Ufuk GÜLÇEN Proje Sorumlusu		Önder KURT Proje Sorumlusu	YEDEK	MCC-14	YEDEK	Esan Eczacıbaşı Milas ÜY YENİ KURUTMA	MCC
								Next page: 65.c
								Previous page: 65.a



Çizen (Drawing)	Kontrol (Control)		Kontrol (Control)		Tag Number	Lokasyon	Sayfa açıklaması (Page description)	Proje adı (Project name)	=
Necip SERT Proje Tasarım	Ufuk GÜLÇEN Proje Sorumlusu		Önder KURT Proje Sorumlusu		YEDEK	MCC-14	YEDEK	Esan Eczacıbaşı Milas ÜYS YENİ KURUTMA	+ MCC
									Next page: 66.a
									Previous page: 65.b

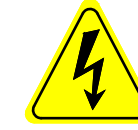

**!!! DİKKAT !!!**  
 MOTOR YOL VERİCİ KORUMA ŞALTERİ  
 HIZ KONTROL (VFD) GÜCÜNE GÖRE SEÇİLMİŞTİR .  
 MOTOR KORUMA FONKSİYONU  
 HIZ KONTROL (VFD) TARAFINDAN YAPILMAKTADIR .

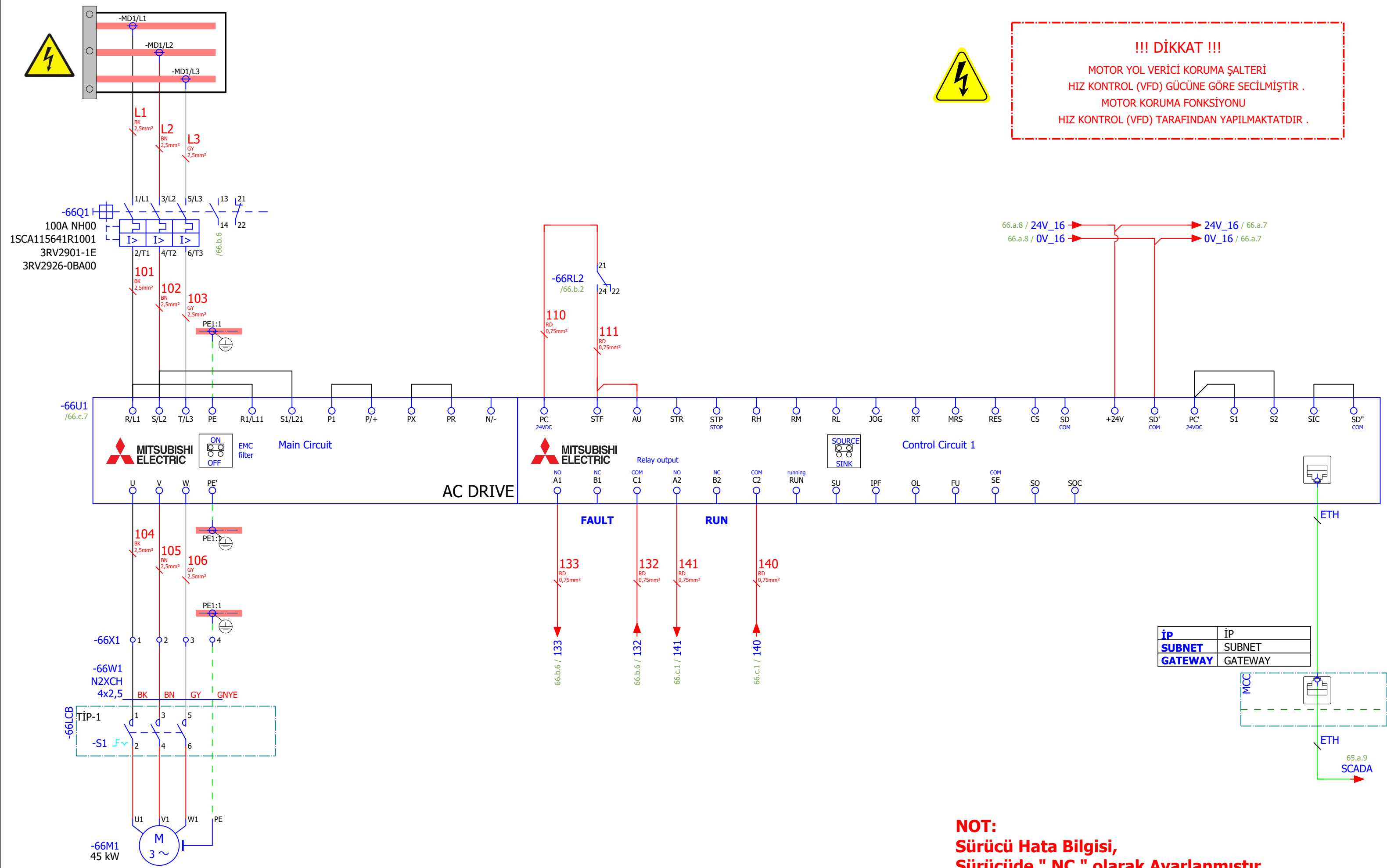

66.a.8 / 24V\_16 → 24V\_16 / 66.a.7  
 66.a.8 / 0V\_16 → 0V\_16 / 66.a.7

İP	İP
SUBNET	SUBNET
GATEWAY	GATEWAY



**NOT:**  
 Sürücü Hata Bilgisi,  
 Sürücüde " NC " olarak Ayarlanmıştır...

Cizen (Drawing)	Kontrol (Control)		Kontrol (Control)		Tag Number	Lokasyon	Sayfa açıklaması (Page description)	Proje adı (Project name)	=
Necip SERT Proje Tasarım	Ufuk GÜLÇEN Proje Sorumlusu		Önder KURT Proje Sorumlusu		YEDEK	MCC-16	YEDEK	Esan Eczacıbaşı Milas ÜYS YENİ KURUTMA	Next page: 66.b
									Previous page: 65.c



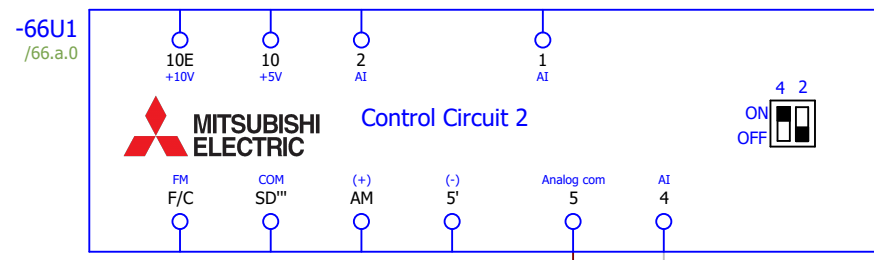
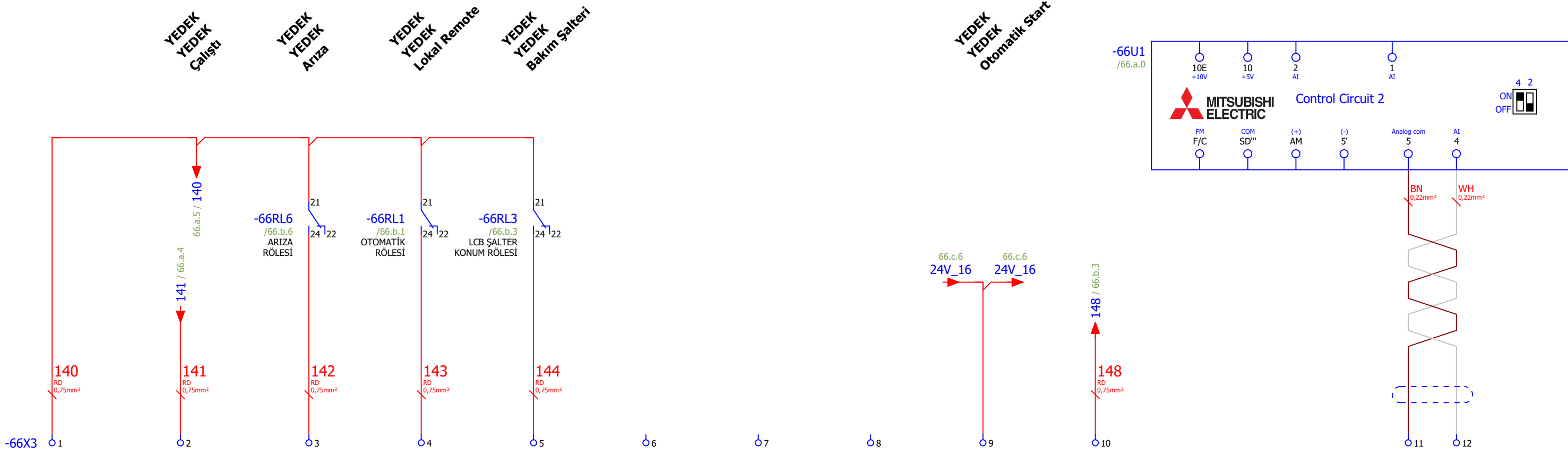



Çizen (Drawing)	Kontrol (Control)		Kontrol (Control)		Tag Number	Lokasyon	Sayfa açıklaması (Page description)	Proje adı (Project name)	=
Necip SERT Proje Tasarım	Ufuk GÜLÇEN Proje Sorumlusu		Önder KURT Proje Sorumlusu		YEDEK	MCC-16	YEDEK	Esan Eczacıbaşı Milas ÜYS YENİ KURUTMA	+ MCC
									Next page: 67.a
									Previous page: 66.b

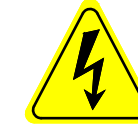

**!!! DİKKAT !!!**  
 MOTOR YOL VERİCİ KORUMA ŞALTERİ  
 HIZ KONTROL (VFD) GÜCÜNE GÖRE SEÇİLMİŞTİR .  
 MOTOR KORUMA FONKSİYONU  
 HIZ KONTROL (VFD) TARAFINDAN YAPILMAKTADIR .

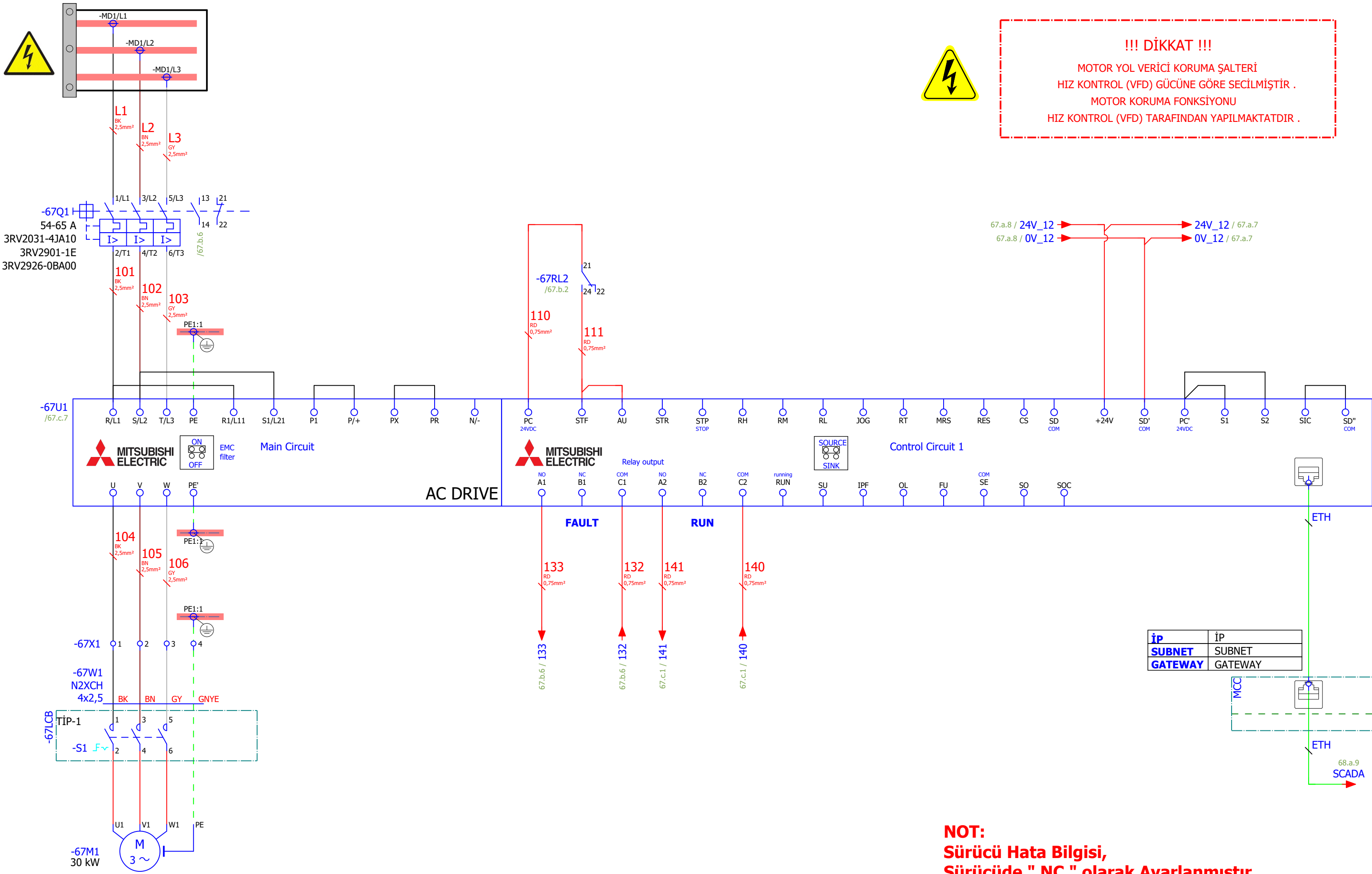

İP	İP
SUBNET	SUBNET
GATEWAY	GATEWAY

**NOT:**  
 Sürücü Hata Bilgisi,  
 Sürücüde " NC " olarak Ayarlanmıştır...

Cizen (Drawing)	Kontrol (Control)		Kontrol (Control)		Tag Number	Lokasyon	Sayfa açıklaması (Page description)	Proje adı (Project name)	=
Necip SERT Proje Tasarım	Ufuk GÜLÇEN Proje Sorumlusu		Önder KURT Proje Sorumlusu		YEDEK	MCC-12.2	YEDEK	Esan Eczacıbaşı Milas ÜYS YENİ KURUTMA	66.c
									Next page: 67.b
									Previous page: 66.c

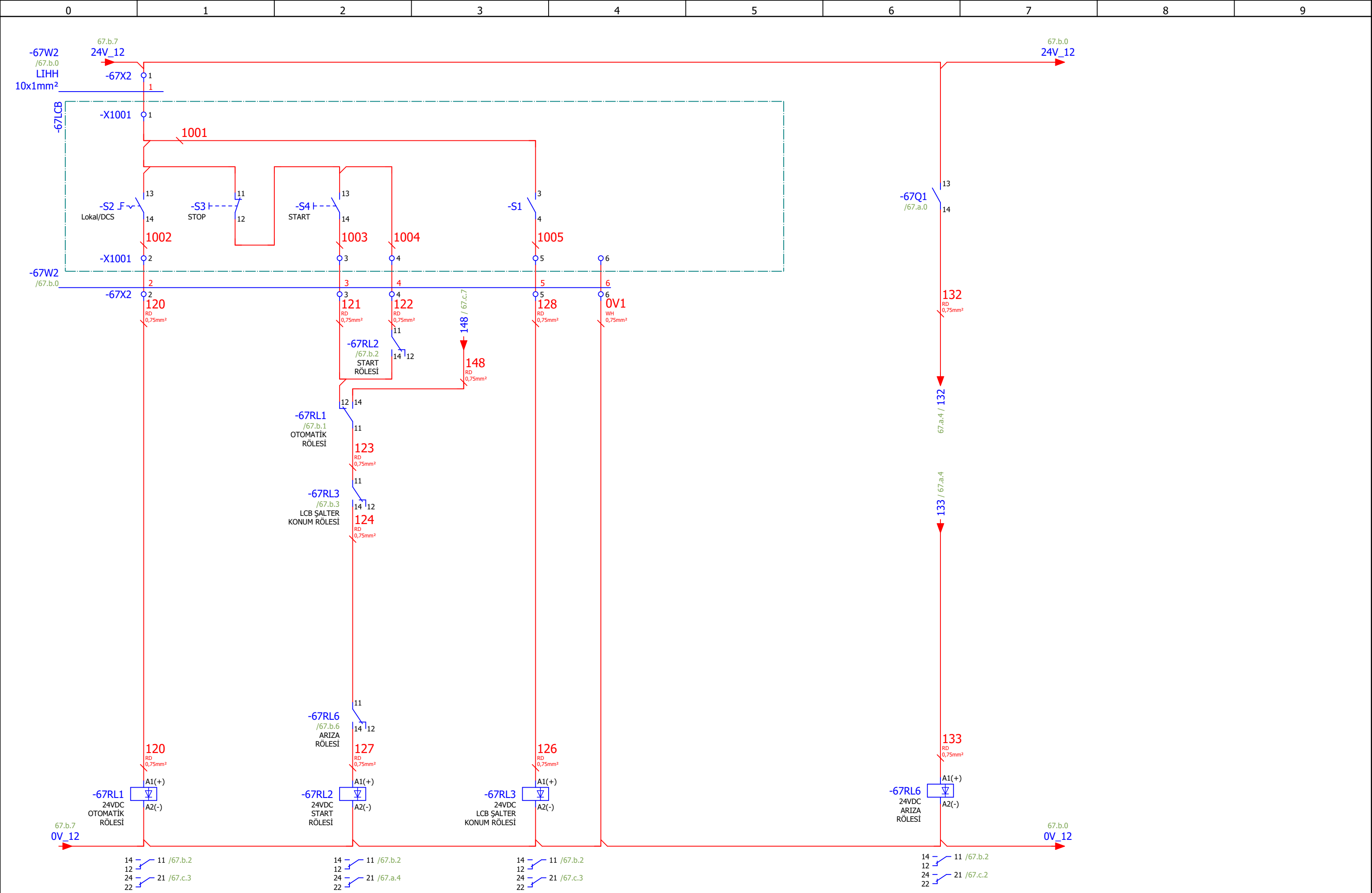



67.a

Page: 67.b

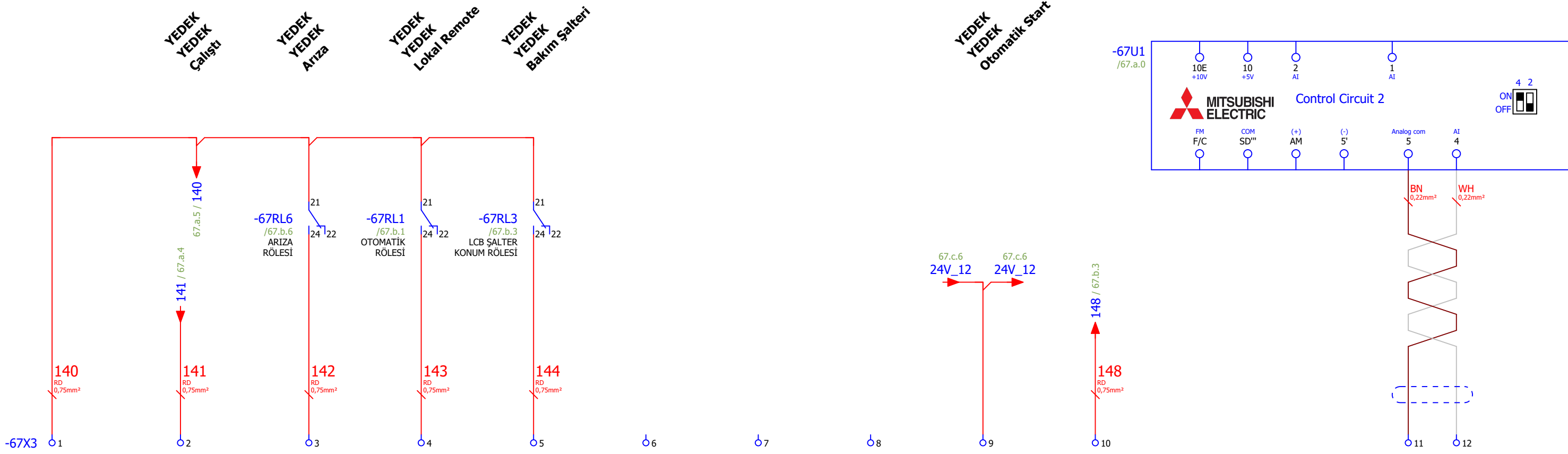
Çizen (Drawing)	Kontrol (Control)	USIA	Kontrol (Control)	Tag Number	Lokasyon	Sayfa açıklaması (Page description)	Proje adı (Project name)	=
Necip SERT Proje Tasarım	Ufuk GÜLÇEN Proje Sorumlusu		Önder KURT Proje Sorumlusu	YEDEK	MCC-12.2	YEDEK	Esan Eczacıbaşı Milas ÜYİ YENİ KURUTMA	MCC
								Next page: 67.c
								Previous page: 67.a



Çizen (Drawing)	Kontrol (Control)		Kontrol (Control)		Tag Number	Lokasyon	Sayfa açıklaması (Page description)	Proje adı (Project name)	=
Necip SERT Proje Tasarım	Ufuk GÜLÇEN Proje Sorumlusu		Önder KURT Proje Sorumlusu		YEDEK	MCC-12.2	YEDEK	Esan Eczacıbaşı Milas ÜYS YENİ KURUTMA	+ MCC
									Next page: 68.a
									Previous page: 67.b



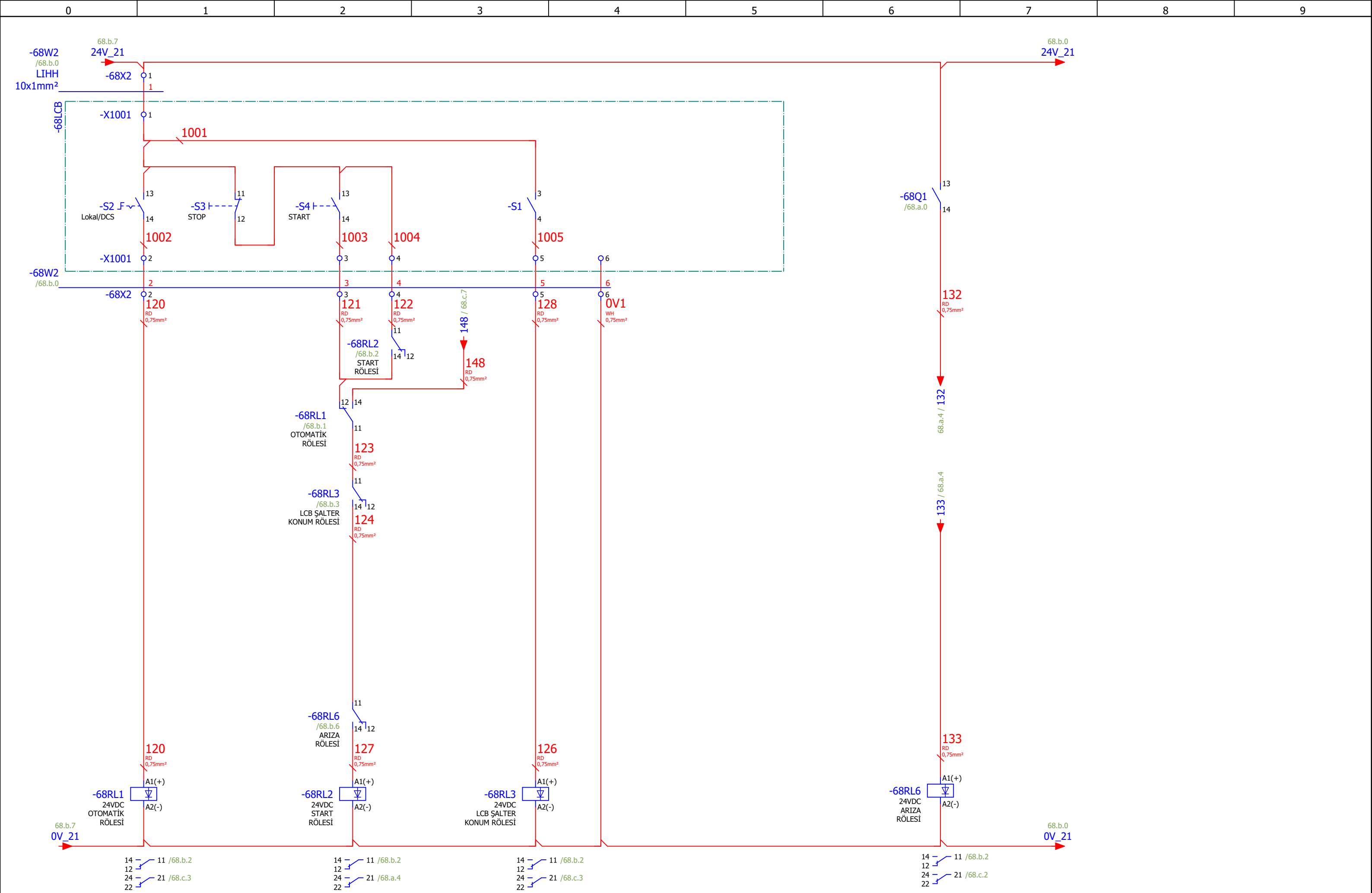



68.a

Page: 68.b

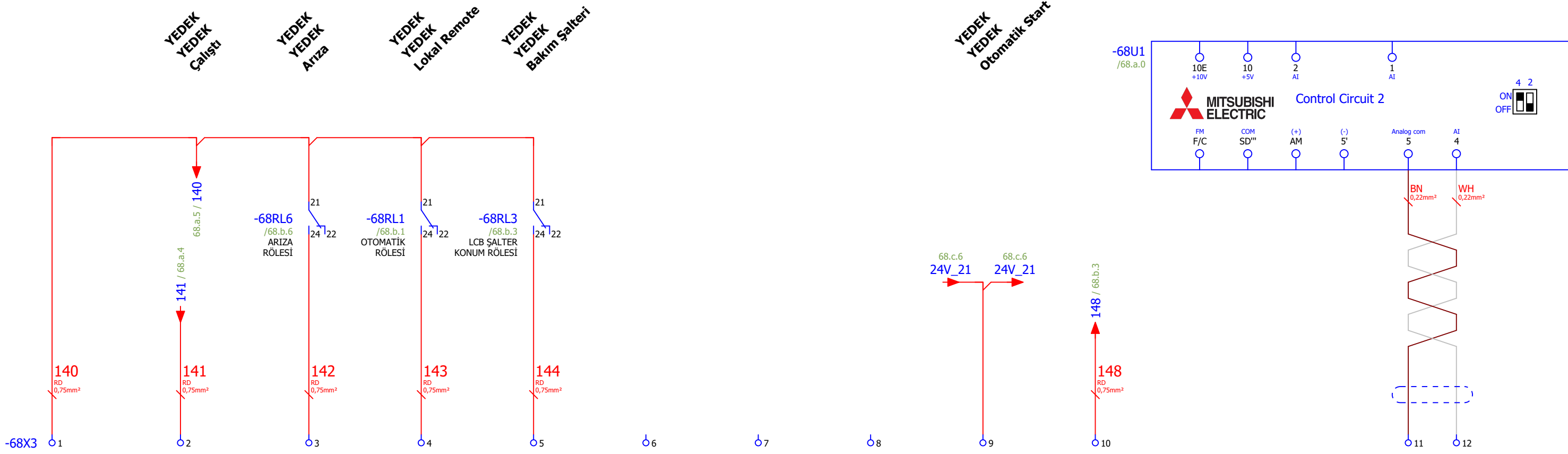
Çizen (Drawing)	Kontrol (Control)	USIA	Kontrol (Control)	es	Tag Number	Lokasyon	Sayfa açıklaması (Page description)	Proje adı (Project name)	=
Necip SERT Proje Tasarım	Ufuk GÜLÇEN Proje Sorumlusu		Önder KURT Proje Sorumlusu		YEDEK	MCC-21.4	YEDEK	Esan Eczacıbaşı Milas ÜY YENİ KURUTMA	MCC
									Next page: 68.c
									Previous page: 68.a



Çizen (Drawing)	Kontrol (Control)		Kontrol (Control)		Tag Number	Lokasyon	Sayfa açıklaması (Page description)	Proje adı (Project name)	=
Necip SERT Proje Tasarım	Ufuk GÜLÇEN Proje Sorumlusu		Önder KURT Proje Sorumlusu		YEDEK	MCC-21.4	YEDEK	Esan Eczacıbaşı Milas ÜYS YENİ KURUTMA	+ MCC
									Next page: 80.a
									Previous page: 68.b



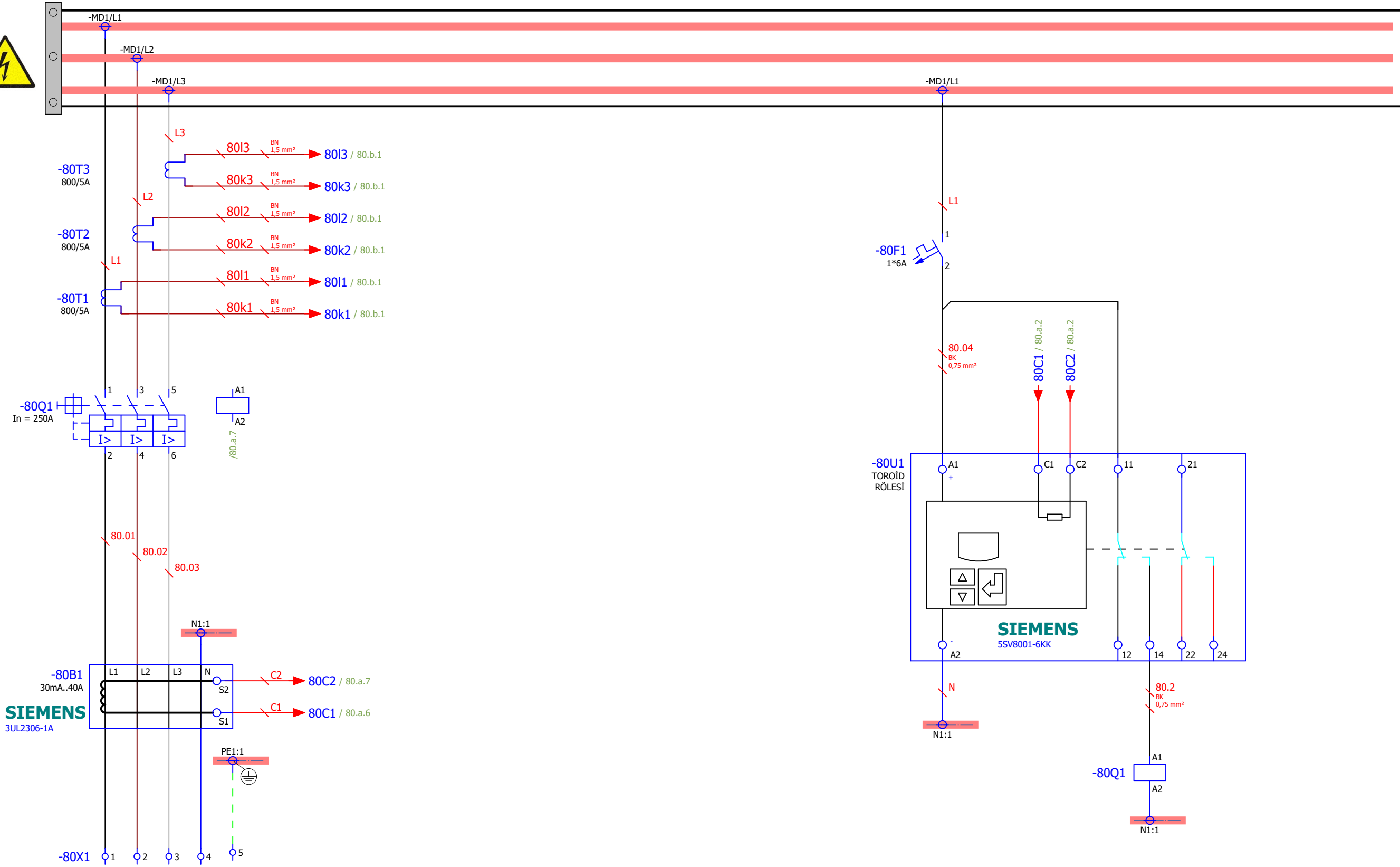

**TOZ TOPLAMA ÜNİTESİ  
ANA ŞALTER**

Çizen (Drawing)	Kontrol (Control)	USIA	Kontrol (Control)	esana	Tag Number	Lokasyon	Sayfa açıklaması (Page description)	Proje adı (Project name)	=
Necip SERT Proje Tasarım	Ufuk GÜLÇEN Proje Sorumlusu		Önder KURT Proje Sorumlusu			MCC-10	250A ÇIKIŞ	Esan Eczacıbaşı Milas ÜYS YENİ KURUTMA	+ MCC
									Next page: 80.b
									Previous page: 68.c



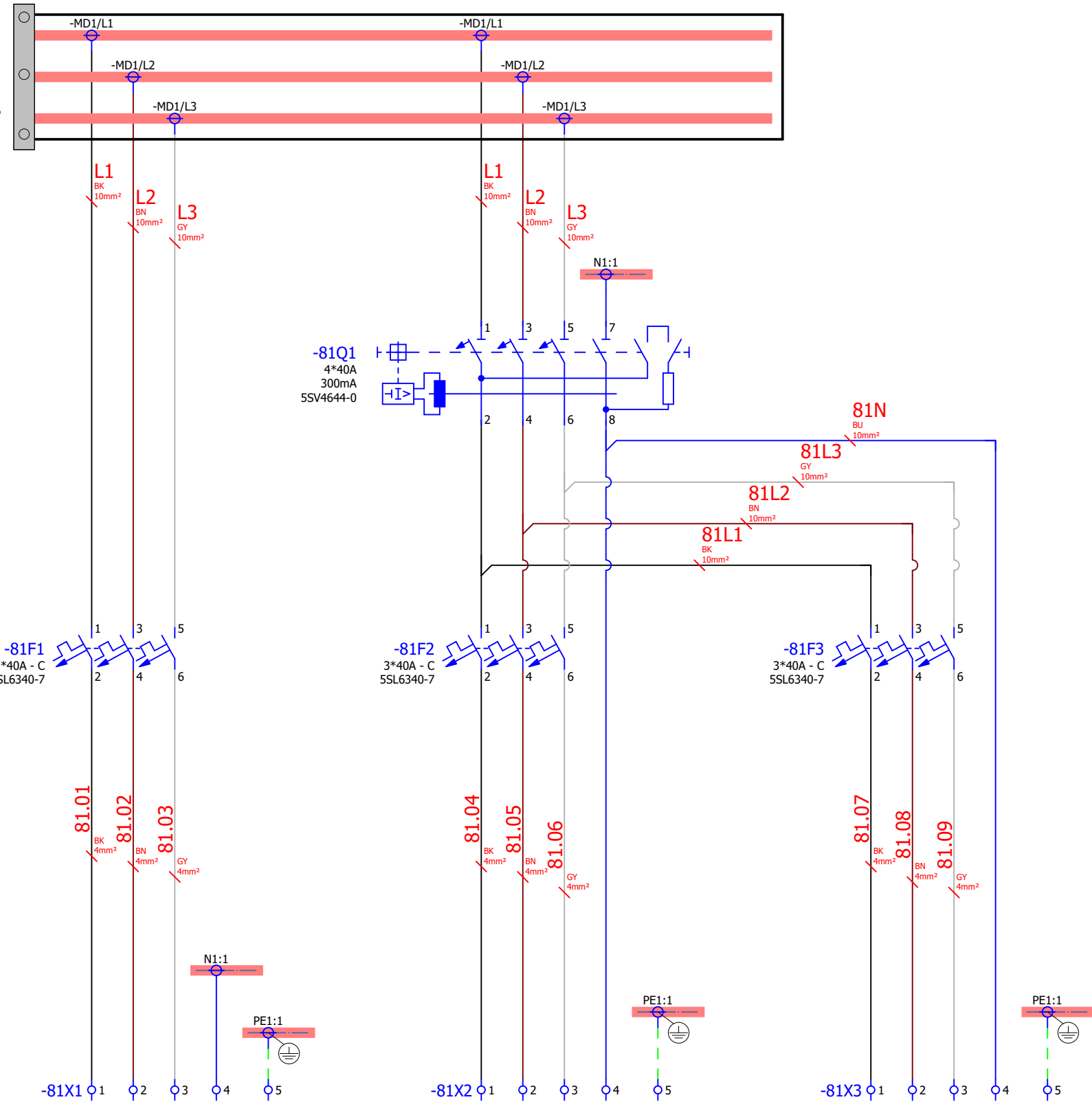

**DRY2-BLW001XM1  
BRULÖR  
BESLEME**

**KOMBİNASYON**

**MCC ODA  
KLİMA BESLEME**

Cizen (Drawing)	Kontrol (Control)	USIA	Kontrol (Control)	esan	Tag Number	Lokasyon	Sayfa açıklaması (Page description)	Proje adı (Project name)	=
Necip SERT Proje Tasarım	Ufuk GÜLÇEN Proje Sorumlusu		Önder KURT Proje Sorumlusu			MCC-10	ÇIKIŞLAR-1	Esan Eczacıbaşı Milas ÜYS YENİ KURUTMA	+ MCC
									Next page: 82
									Previous page: 80.b



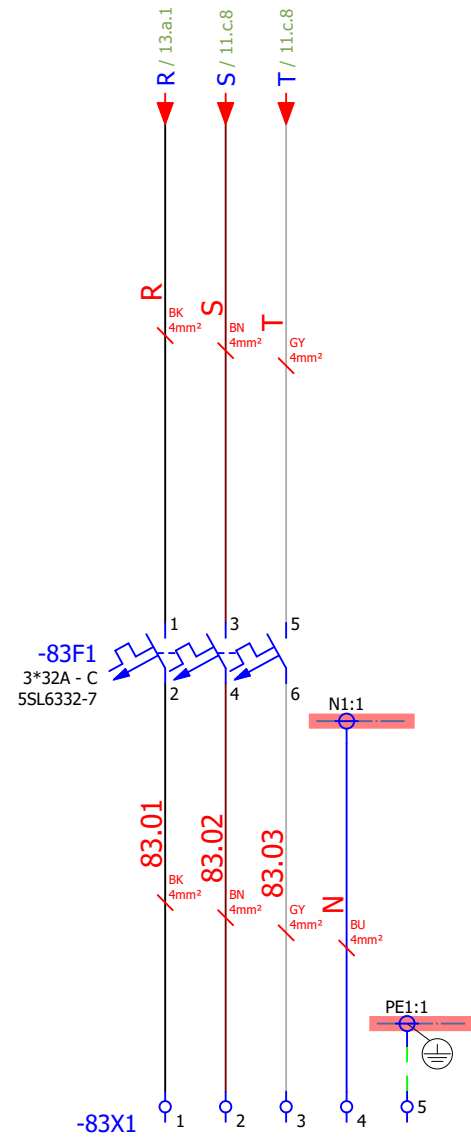

Cizen (Drawing)	Kontrol (Control)	USIA Unique Software Applications an EPC company	Kontrol (Control)	esan	Tag Number	Lokasyon	Sayfa açıklaması (Page description)	Proje adı (Project name)	=
Necip SERT Proje Tasarım	Ufuk GÜLÇEN Proje Sorumlusu		Önder KURT Proje Sorumlusu			<b>MCC-10</b>	UPS ÇIKIŞ	Esan Eczacıbaşı Milas ÜYS YENİ KURUTMA	+ MCC
									Next page: 84
									Previous page: 82

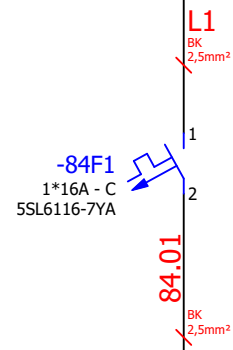

-84RL1  
/84.3  
START  
RÖLESİ

-84X1

-162P2  
220VAC  
YEŞİL

-162P1  
220VAC  
KIRMIZI

TRAFİK LAMBASI

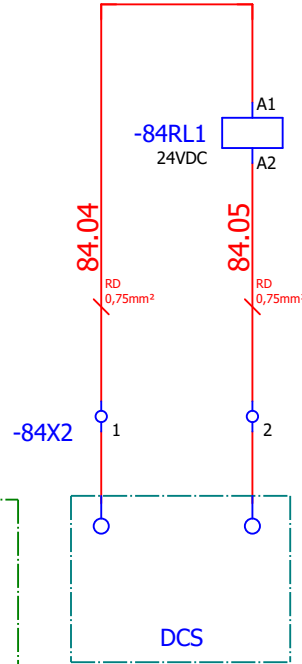

-84RL1  
24VDC

-84X2

DCS

24  
22 /84.1

-84F2  
1\*16A - C  
SSL6116-7YA

-84K1  
/84.9

-84X3

PE1:1

SİREN

13.b.2 / 0V\_1

13.b.2 / 24V\_1

-84K1  
24VDC

-84X4

1 2 /84.6

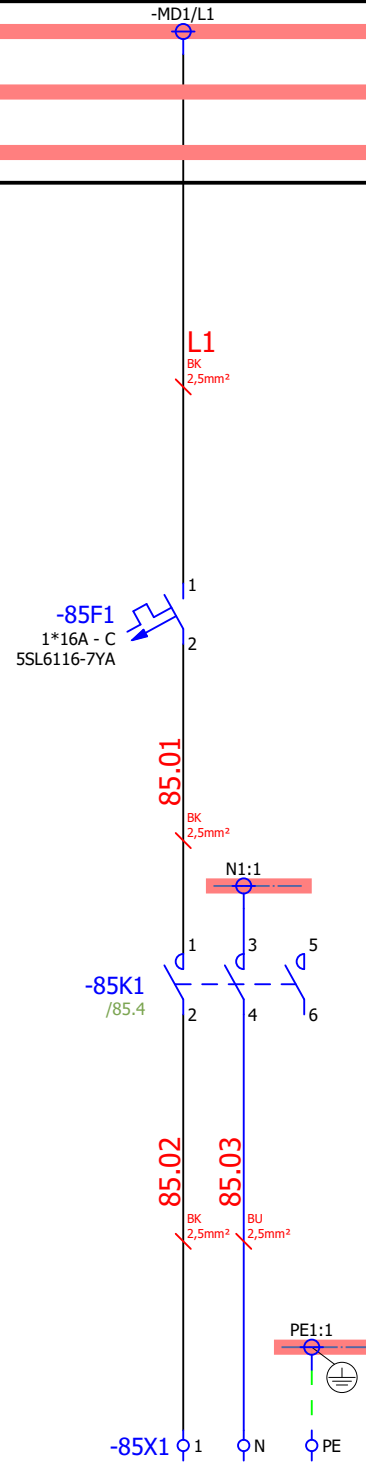

### DÖNER FIRIN YAĞLAMA

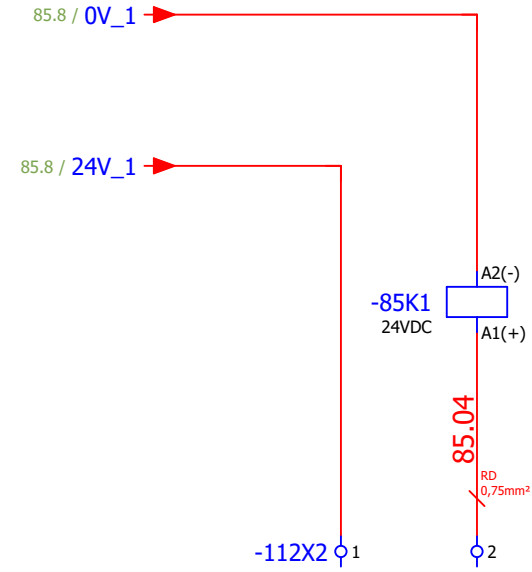

1 2 /85.1

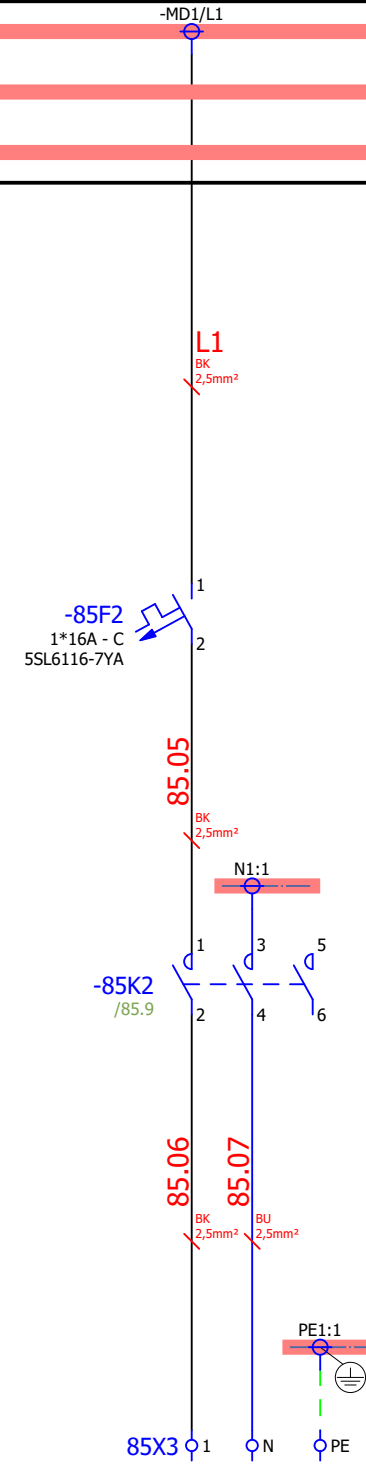

### HAVA TOPU

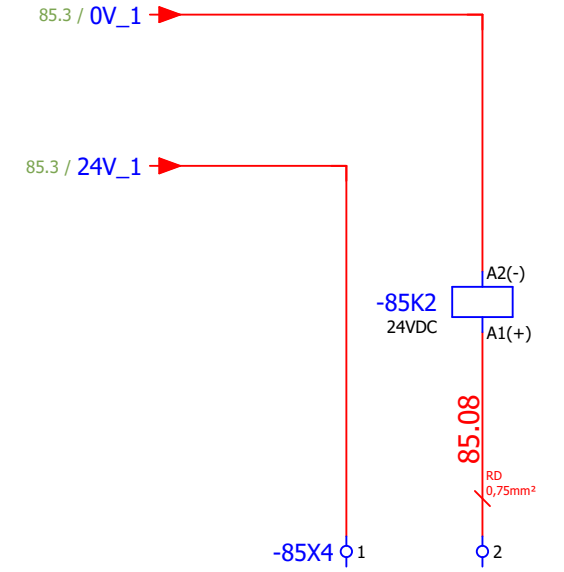

1 2 /85.6

84	Çizen (Drawing) Necip SERT Proje Tasarım	Kontrol (Control) Ufuk GÜLÇEN Proje Sorumlusu	Kontrol (Control) Önder KURT Proje Sorumlusu	es	Tag Number	Lokasyon MCC-24	Sayfa açıklaması (Page description) DÖNER FIRIN YAĞLAMA VE HAVA TOPU	Proje adı (Project name) Esan Eczacıbaşı Milas ÜYS YENİ KURUTMA	= + Next page: +DCS&EFA1/1 Previous page: 84	Page: 85
----	--	---	--	----	------------	--------------------	---	---	---	----------